

Master slide set

Hidden in Plain Sight: The **Secret** History of Silicon Valley

- Multiple copies of each slide
- Select a subset for a specific presentation
- See: <http://steveblank.com/secret-history/> for backstory and videos

Steve Blank
www.steveblank.com

The Genesis of Silicon Valley Entrepreneurship

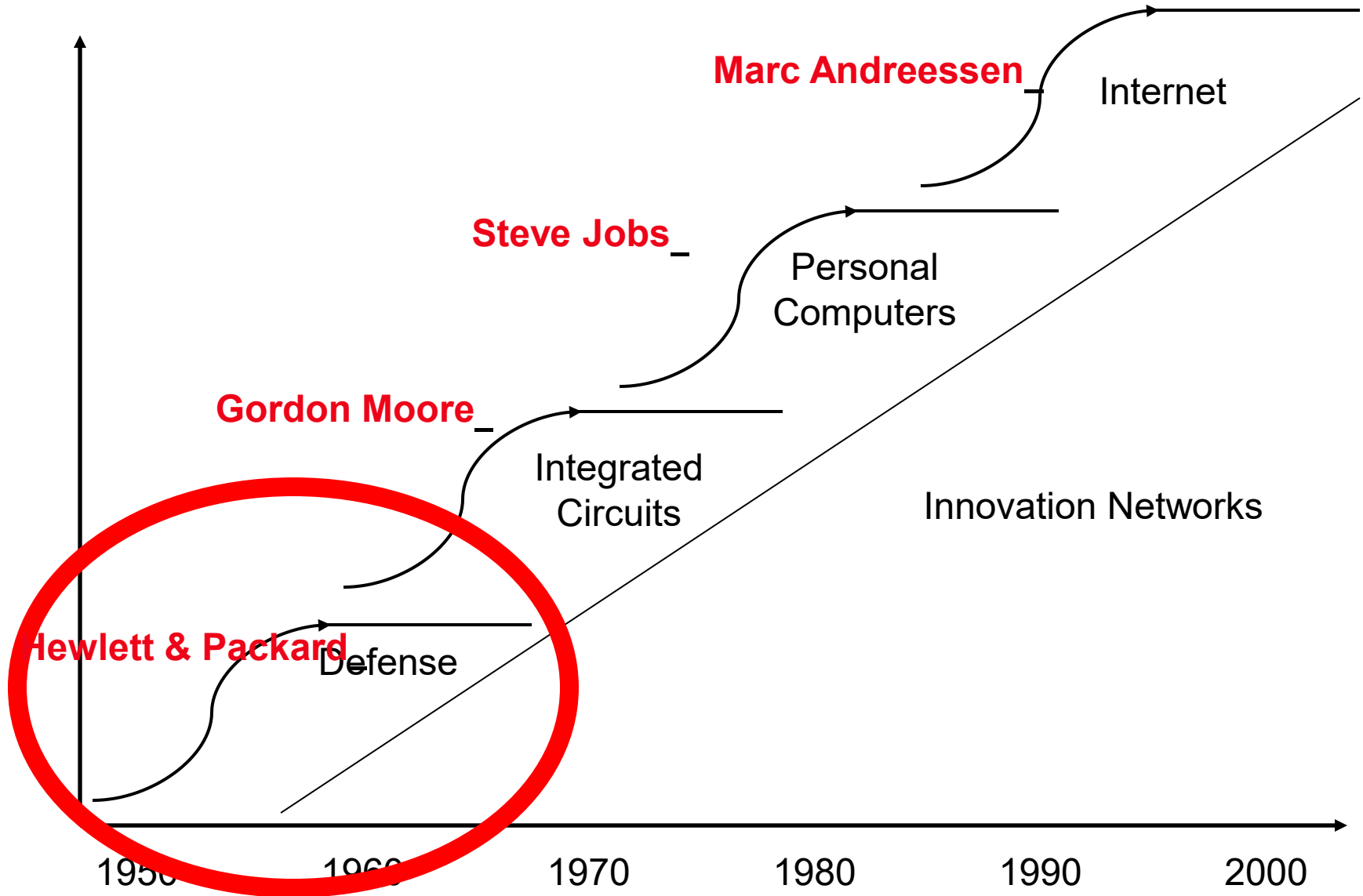

The Popular View of Silicon Valley History

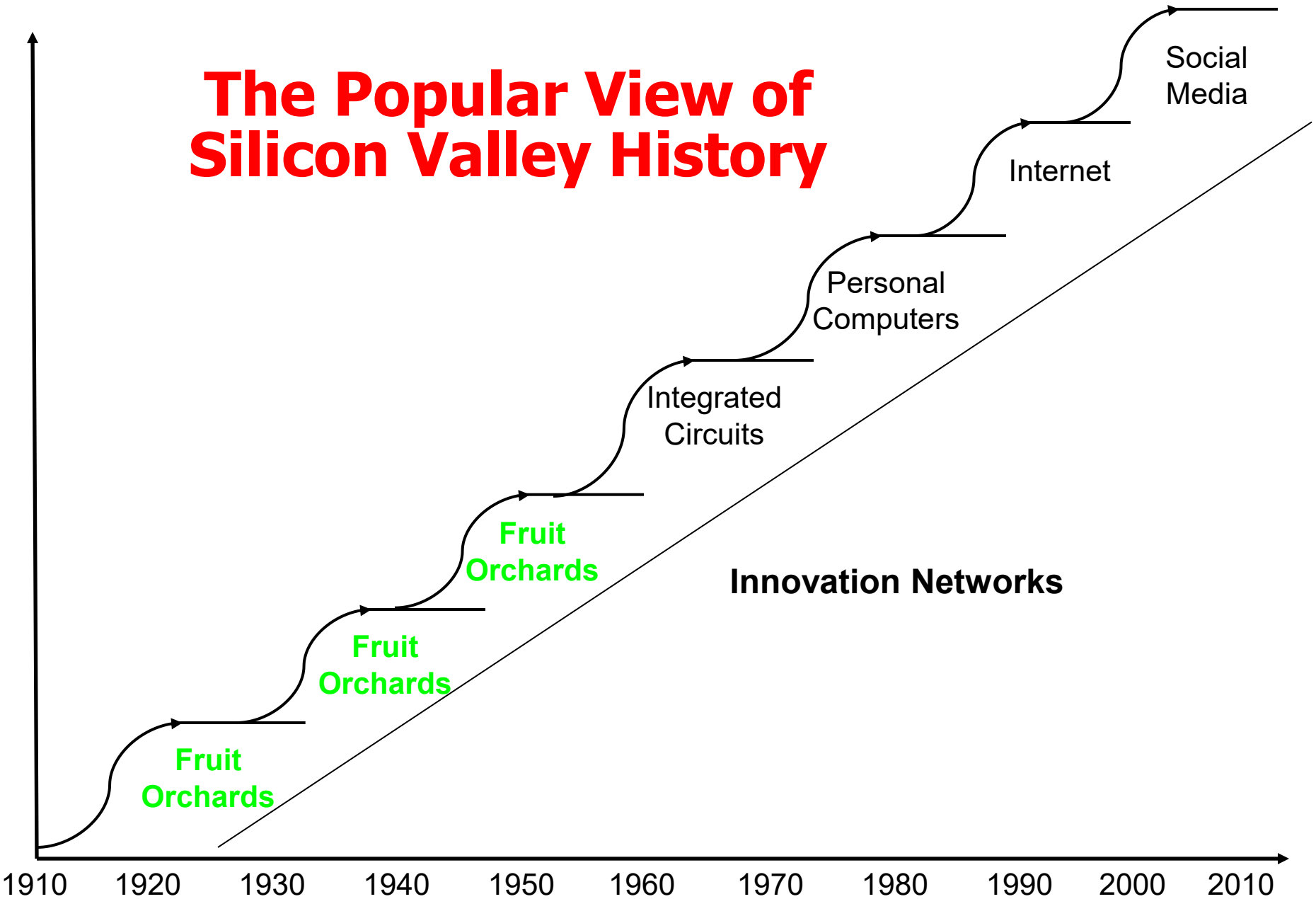

The Real Story of Silicon Valley

Social Media

Internet

Personal Computers

Integrated Circuits

Microwaves

Test Equipment

Vacuum Tubes

Innovation Networks

1910 1920 1930 1940 1950 1960 1970 1980 1990 2000 2010

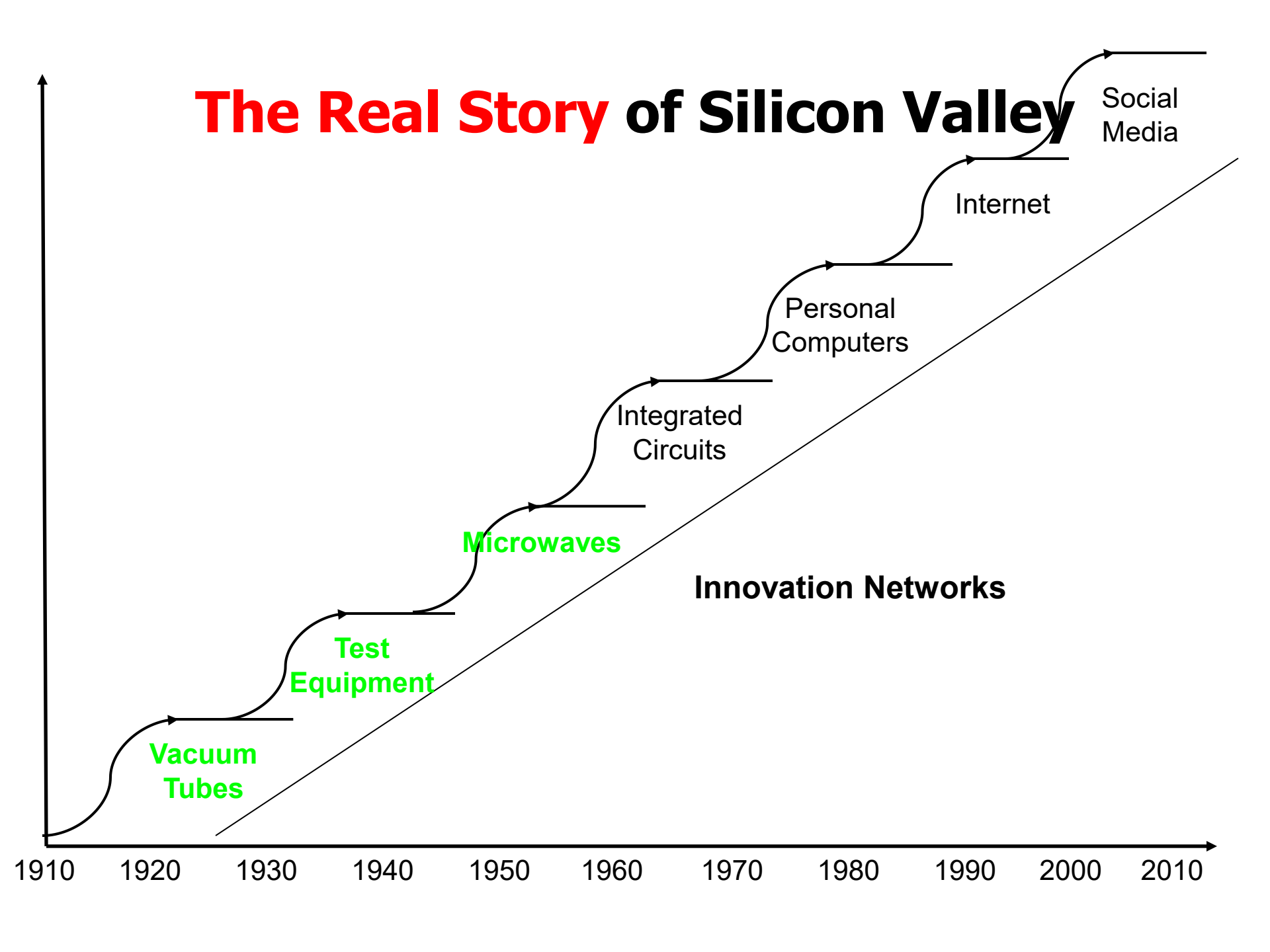

The Real Story of Silicon Valley

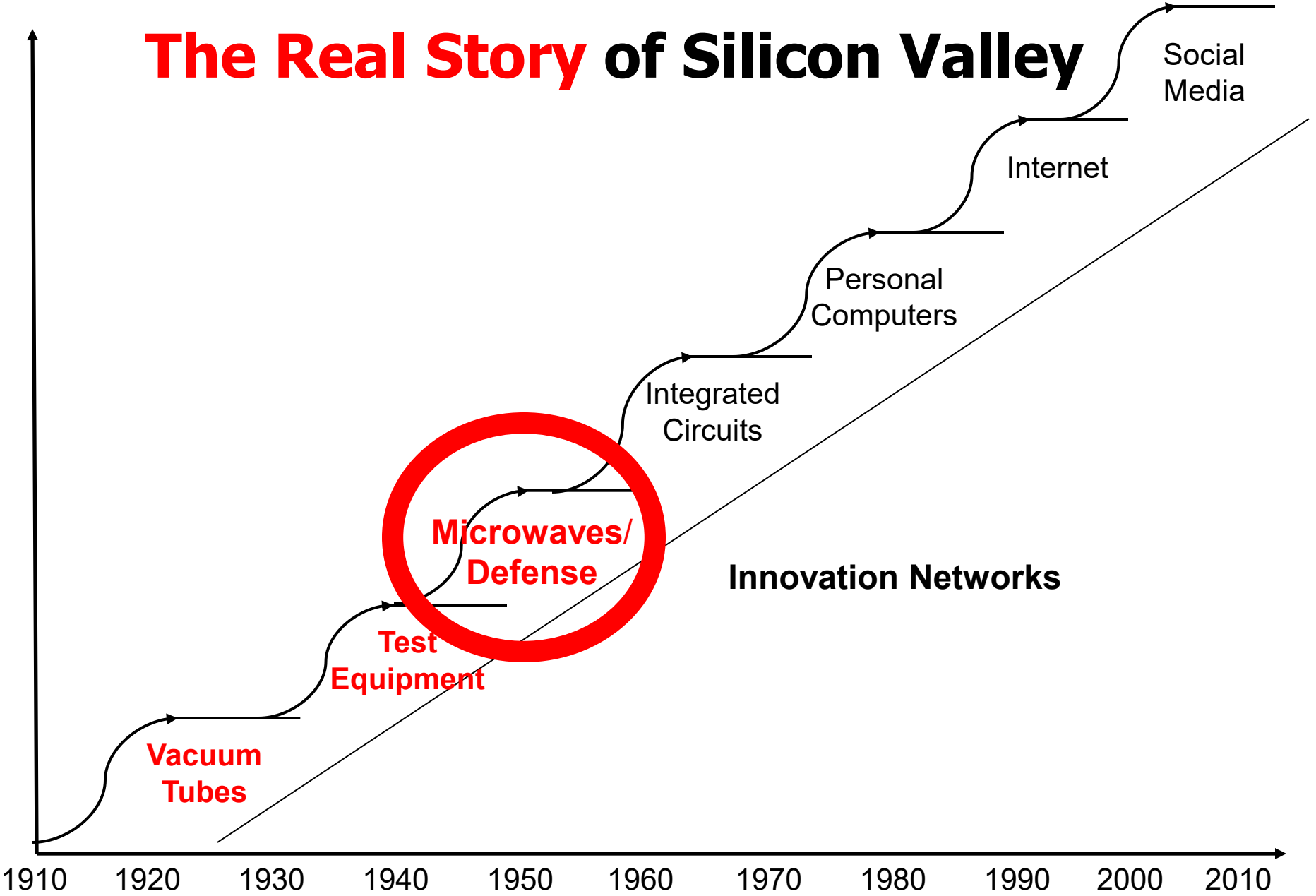

1910 1920 1930 1940 1950 1960 1970 1980 1990 2000 2010

A few caveats

- Intent: fill in the gaps of Silicon Valley history
- Not a professional historian
- Some of this is probably wrong
- It follows just one of many threads
- All “secrets” are from open-source literature

Seven Short Stories

Story 1: WWII The First Electronic War

First Meteorological Use of RADAR

- The first application of RADAR to meteorology was by Sir Robert Watson-Watt (b.1892-d.1973):
 - Used radio signals generated by lightning strikes to detect/locate thunderstorms (so that they may be avoided by RAF aircraft)
 - Location difficulties led to the development of rotating directional antennas
 - Pioneered the idea/use of oscilloscopes as a 2D display device



Robert
Watson-Watt



Watson-Watt apparatus for studying
waveforms of atmospheric

RADAR and World War II

- RADAR development continued at a faster pace during the 1930s in the build-up towards World War II
 - England's Air Ministry pushed for development to counter its vulnerability to the German Luftwaffe
 - Germany's Navy was pushing radar development to counter the superior English naval forces

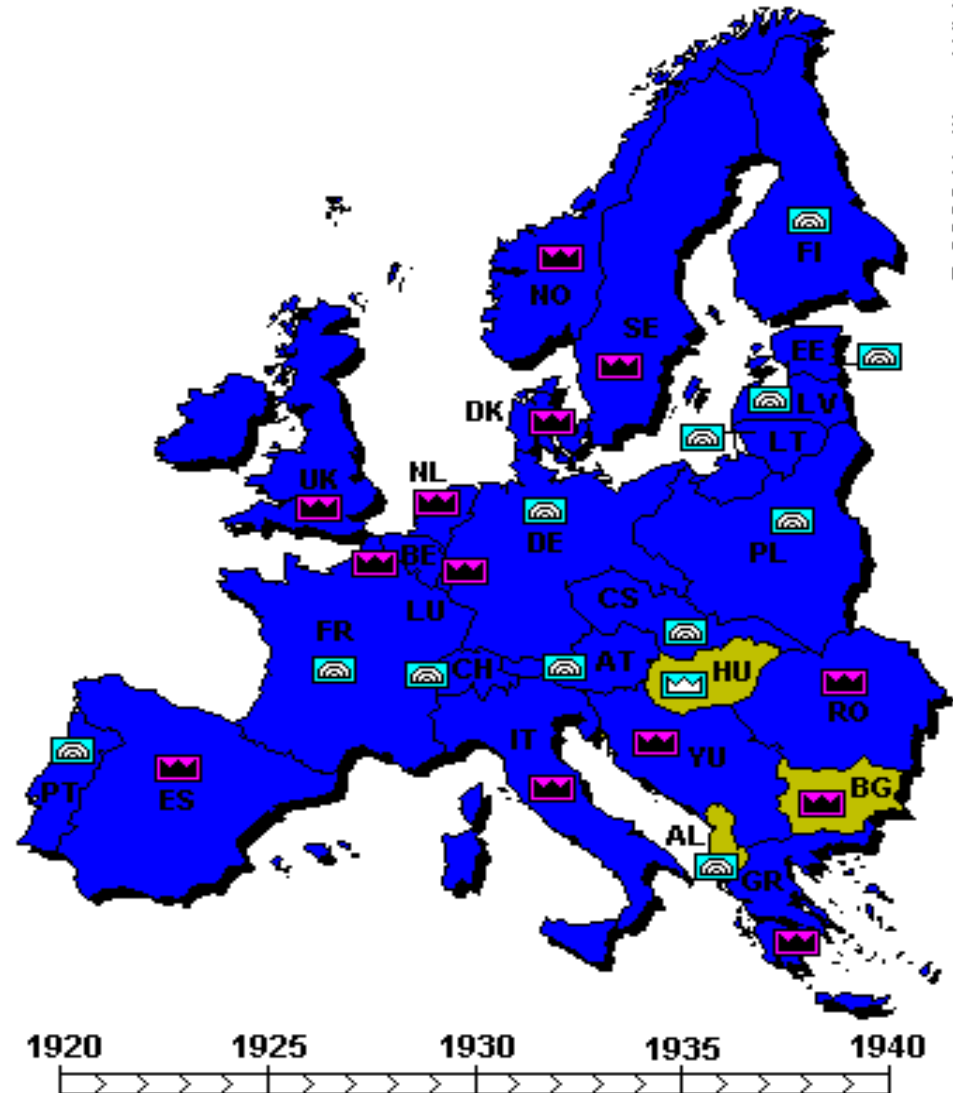

RADAR and World War II

- Some popularized myths concerning British/German radar prior to World War II:
 - The British invented radar and scientist Sir Robert Watson-Watt was the man responsible for its invention
 - The Germans had no little or no pre-war radar capabilities and did not grasp its importance
- Realities:
 - Huelsmeyer had developed and patented the first radar device in 1904
 - In 1934, Dr. Rudolph Kuhnold (head of German Navy signals research) “rediscovers” radar
 - Germany actually had more sophisticated technology leading up to WWII

German RADAR

- Hans Hollmann was the leading technical expert of the time on radar technology:
 - Consultant for both the GEMA and Telefunken corporations—leading manufacturers of radar in the late 1930s
 - Holder of 300 patents (76 in US) on all key components of radar systems (oscillators, transmitters, receivers, cathode ray tube displays, etc.)



Hans Eric Hollmann

German RADAR - Freya

- “Freya” was the first radar produced in quantity for the German Navy:
 - Land-based aircraft detection radar
 - Operated at 120 to 130 MHz
 - Pulsed radar with pulse width of 3 microseconds at a PRF of 500 Hz
 - Peak Power output of 15 to 20 kW
 - Max range of 100 nmi
 - Over 1000 built throughout the war
 - Installed along Germany’s northern coast

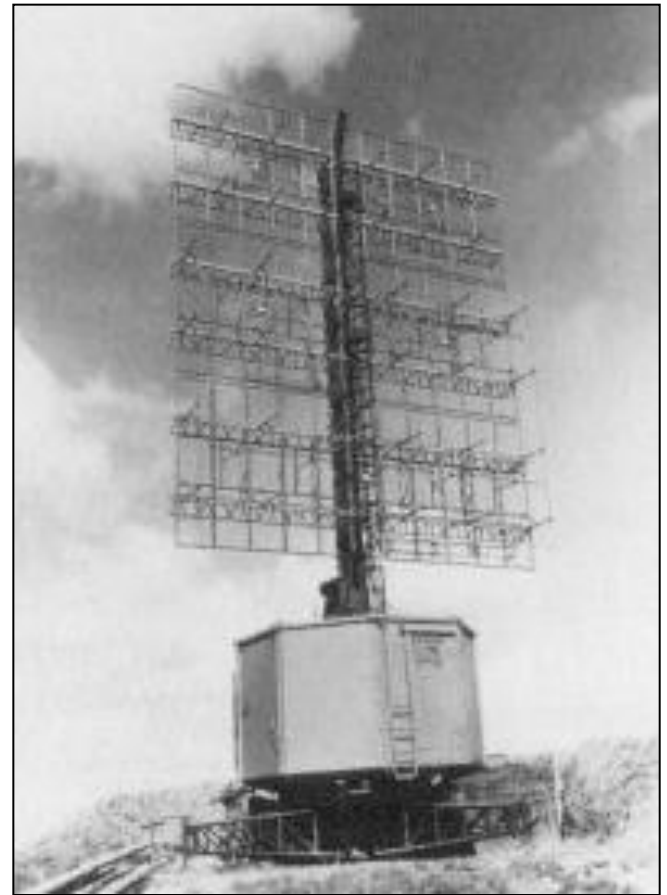

German RADAR - Seetakt

- Adapted from “Freya” radar for ship-board use as a ranging device for gunnery:
 - Operated at 375 MHz
 - Pulse width of 3 microseconds and PRF of 500 Hz
 - Peak Power output of 8 kW
 - Max range of 9 nmi
 - Range accuracy of 70 meters
 - Azimuth accuracy of 3 degrees
 - Over 200 built



German RADAR - Wurzburg

- Telefunken produced a very high accuracy anti-aircraft gun targeting radar, the “Wurzburg”:
 - Operated at 560 MHz (very high frequency for its time)
 - Operating range out to 25 miles
 - Range accuracy of 100 meters
 - Bearing accuracy of 0.2 degrees



British Pre-War RADAR – Killing Sheep

- British investigations into radar began with the question of whether a “death ray” could be produced which could incapacitate or destroy attacking aircraft
- The British Air Ministry had offered a prize of £1000 to the first person who could devise a “death ray” to kill a sheep from 100 yards
- Air Ministry turned to Sir Robert Watson-Watt to investigate whether a “death ray” was practical; his conclusion was that a “death ray” could not be fabricated with the technology of the time (it would require Megawatts of power), but that radio waves could be used for aircraft/ship detection and location
- 1935 – Robert Watson-Watt demonstrates radar for Air Ministry using a BBC transmitter; later that year, an English team of scientists demonstrates detection and three-dimensional locating of aircraft at 100 km range, using a 100 KW transmitter (pulsed) operating in the 5 to 10 MHz frequency range

British Pre-War RADAR – CHAIN

HOME

- CHAIN HOME was a network of “floodlight” radars positioned along the coast of England

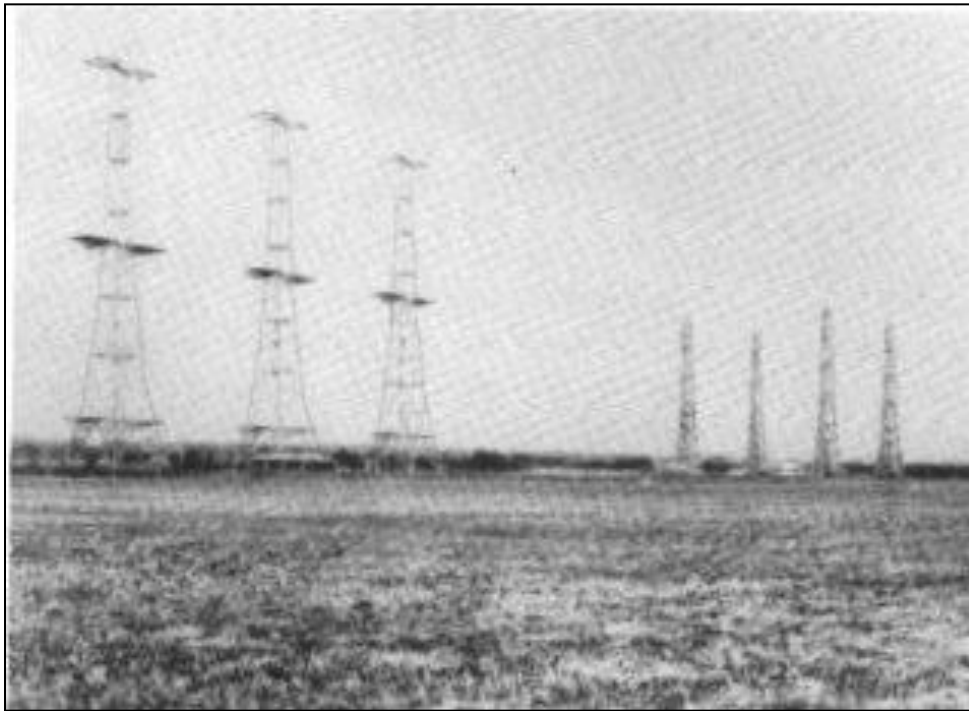

One of the CHAIN HOME radar installations, with transmit towers at left and receive towers at right



British Pre-War RADAR – CHAIN HOME

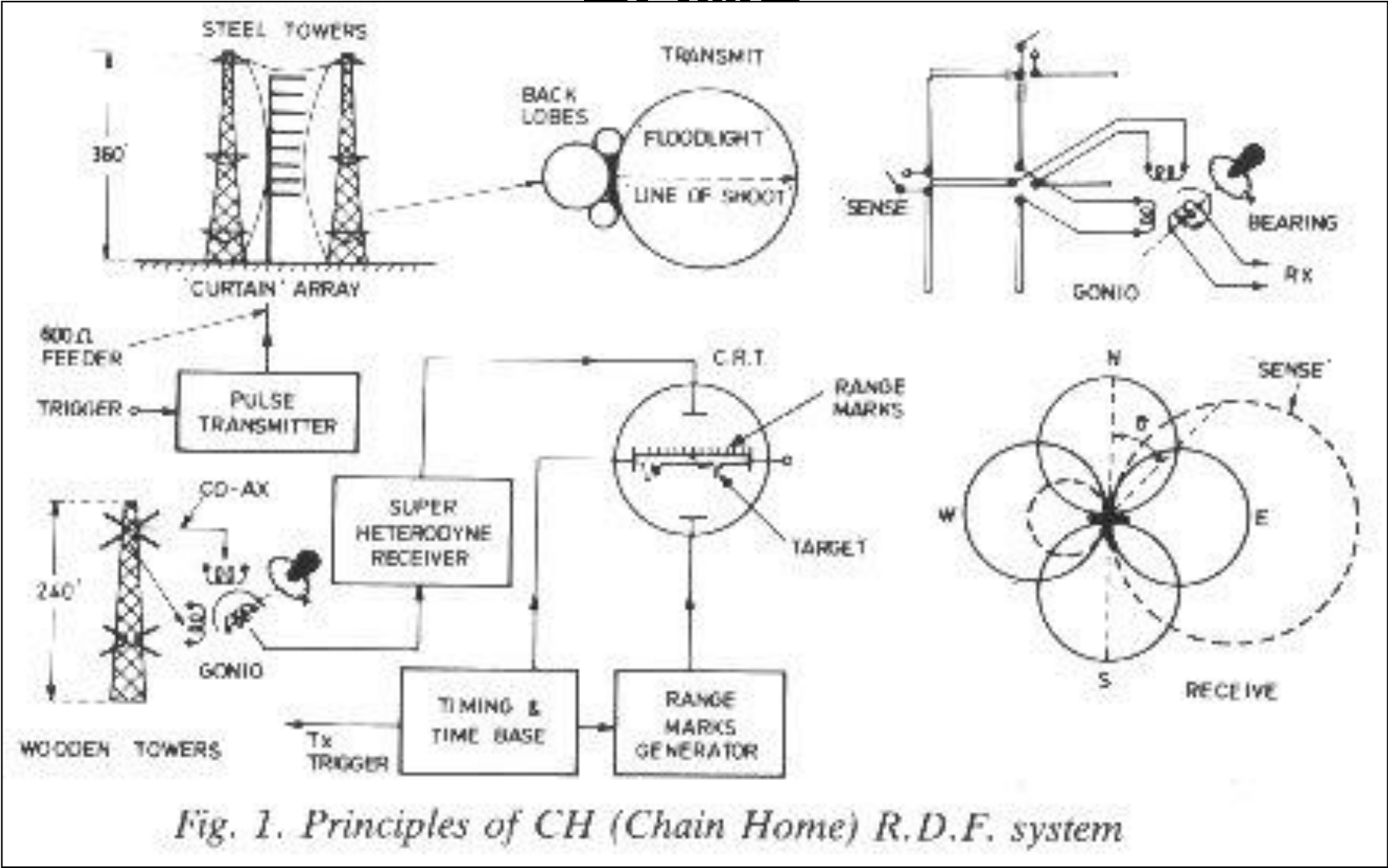

Fig. 1. Principles of CH (Chain Home) R.D.F. system

British Pre-War RADAR – CHAIN HOME

- CHAIN HOME Specifications:

- Frequency: 20 to 30 MHz
- Power: 350 KW (later 750)
- PRF: 25 and 12.5 Hz
- Pulse: 20 us
- Range: ~ 200 nmi

- There were 18 CHAIN HOME sites, time synchronized so that one system within the network would not interfere with another; the pulse timing was synchronized to the national 50 Hz power grid

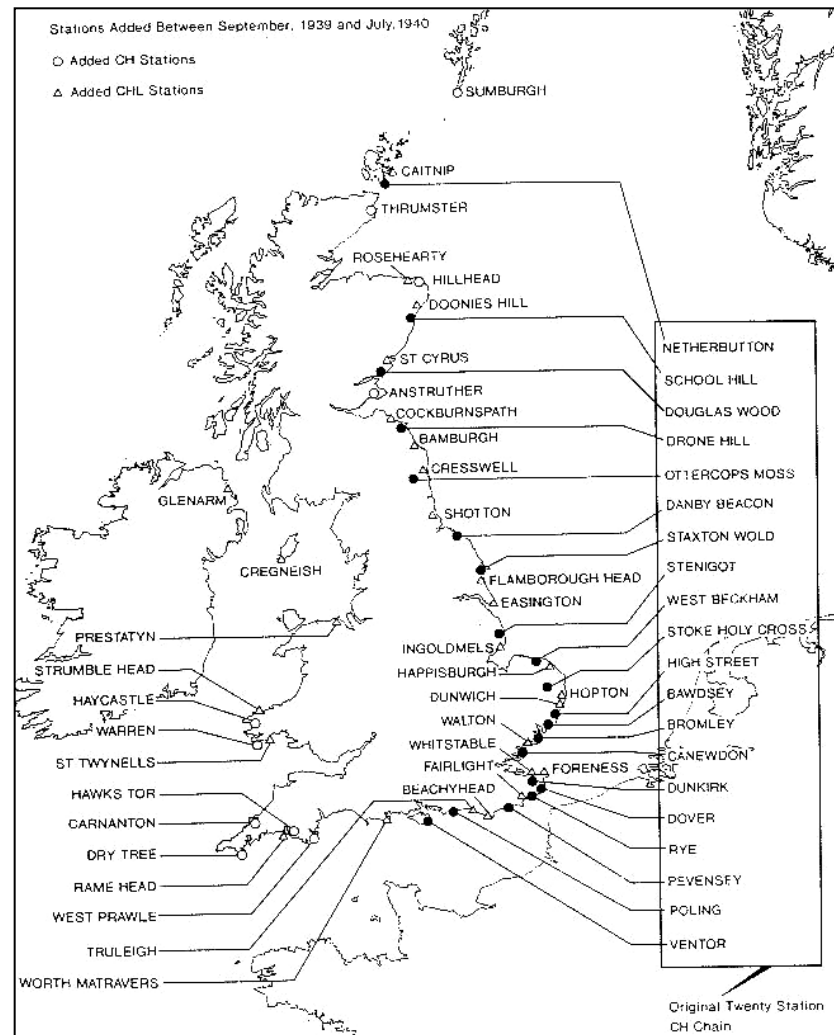

British Pre-War RADAR – CHAIN HOME

- brute force approach to radar
 - low frequencies 20 – 30 MHz
 - high peak power (350 kW, later 750 kW)
 - pulse of 20 μ s duration
 - separate transmit and receive antenna arrays (for isolation)
 - very low (25 or 12.5 Hz) pulse repetition frequency
 - locked to the frequency of the power grid so that all CH stations were synchronized to avoid mutual interference
 - fixed, broad- beamwidth - floodlight transmit illumination.
- receive antenna array
 - stacked orthogonal, half-wave dipoles for azimuth and elevation angle estimates and null filling
 - mounted on wooden towers at a height of 215 ft above the ground,
- direction- and height-finding performed by a goniometer

Comparing British and German Systems

- Britain
 - Had only one system in operation prior to WWII, CHAIN HOME
 - Had a sophisticated, coordinated plan for use of the system
 - Had highly trained staffing and communications
 - Had backup systems in place, anti-jamming, redundancy, etc.
 - Technologically inferior, but superior as an end-to-end system
 - RADAR was integrated into the overall battle strategy
- Germany
 - Had several systems in operation
 - Technologically superior (rotating high gain antennas, higher frequency of operation, superior range/bearing measurements)
 - Multiple-use systems – detection, anti-aircraft gun targeting, bomb targeting, etc.
 - Not employed in a coordinated strategy

World War II Advancements

- Pre-War British program was to set up CHAIN HOME, but this provided nothing in terms of capabilities for anti-aircraft gun targeting, bomb targeting, etc.
- The British and American radar programs were using low frequency radars (the prevailing technology at that time), which severely limited their usefulness
- Britain was pushing very hard to generate microwave frequency radar components
 - Clarendon Laboratory of Oxford directed to develop microwave receivers
 - University of Birmingham directed to develop microwave transmitters

World War II Advancements

- The most significant advancement was achieved at the University of Birmingham by John Randall and Henry Boot, the “cavity magnetron”

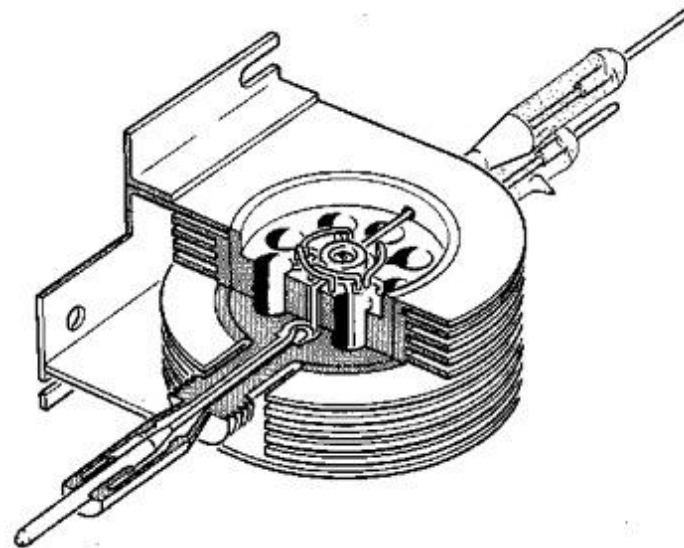

Cavity Magnetron Operation

Hot cathode emits electrons which travel outward

Stable magnetic field B

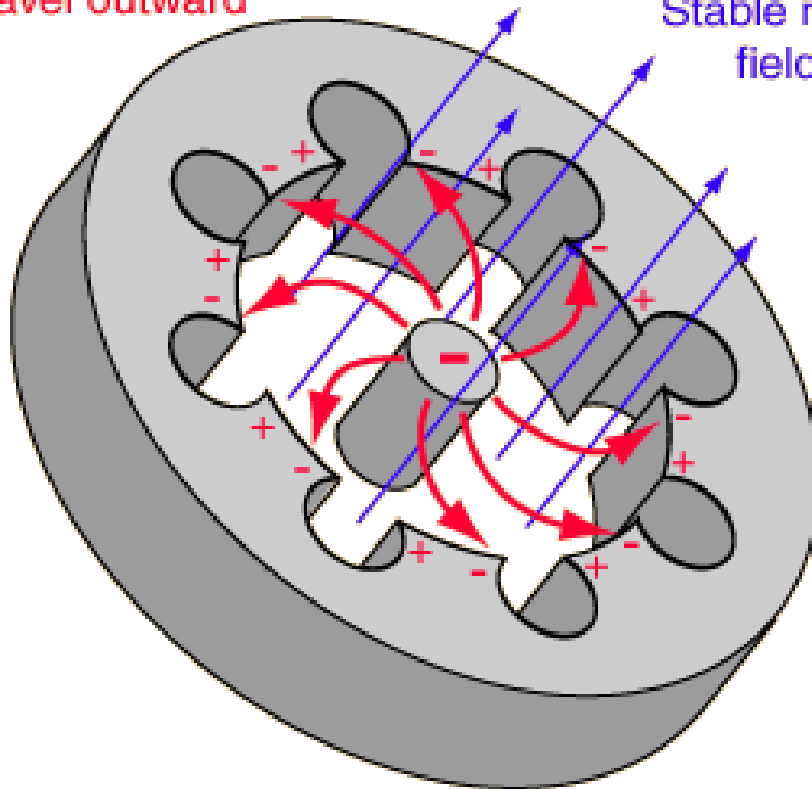

Electrons from a hot filament would travel radially to the outside ring if it were not for the magnetic field. The magnetic force deflects them in the sense shown and they tend to sweep around the circle. In so doing, they "pump" the natural resonant frequency of the cavities. The currents around the resonant cavities cause them to radiate electromagnetic energy at that resonant frequency.

Cavity Magnetron Operation

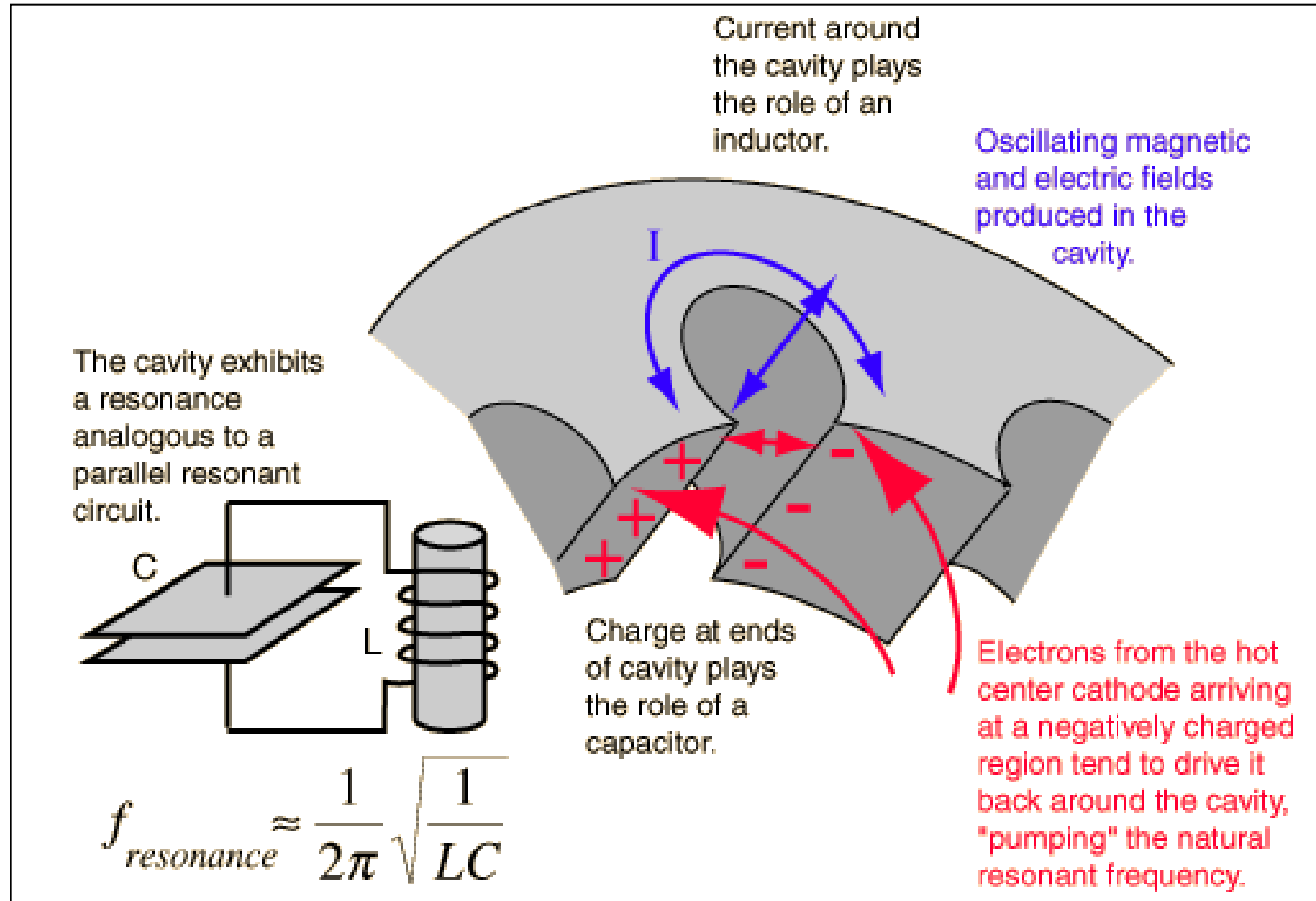

The Cavity Magnetron

Improvement

- By mid-1940, Britain had succeeded in improving on the prototype cavity magnetron, producing a relatively small, light-weight transmitter which could generate RF pulses at 3 GHz, with an output power of 15 KW
- Factor of 10 improvement in operating frequency over German radar
 - Since antenna gain is inversely proportional to wavelength squared, an antenna of the same size could now produce beams 100 times more powerful
 - Since antenna beamwidth is inversely proportional to wavelength, a 3 GHz radar is 10 times as accurate in each dimension (azimuth and elevation) in determining target bearing

Receiver Technology

- Modern radio and radar receiver operation principles were developed in the 1920s and 1930s
 - Vacuum tube (thermionic valve) oscillators, amplifiers, and detectors
 - Superhet (supersonic heterodyne) receiver
- Developed to overcome sensitivity/reliability problems in radio communications
- Radar receivers use these same techniques, but operate at higher frequencies

Triode Vacuum Tube

- Triode, invented by Lee De Forest in 1906

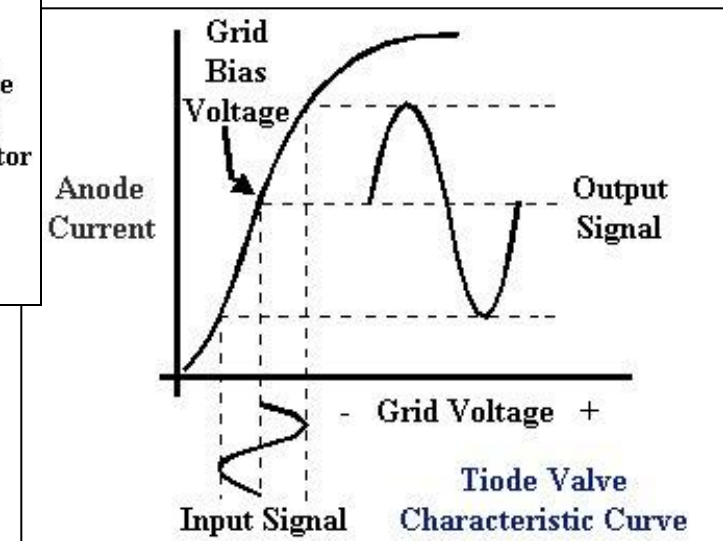
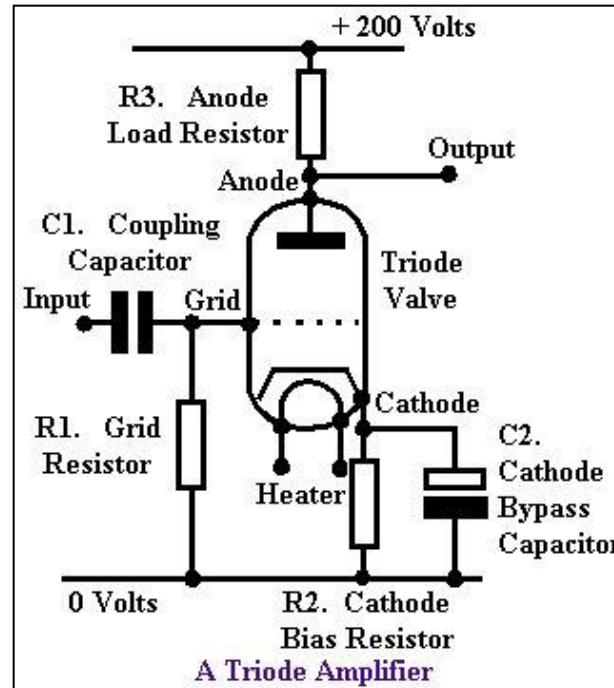
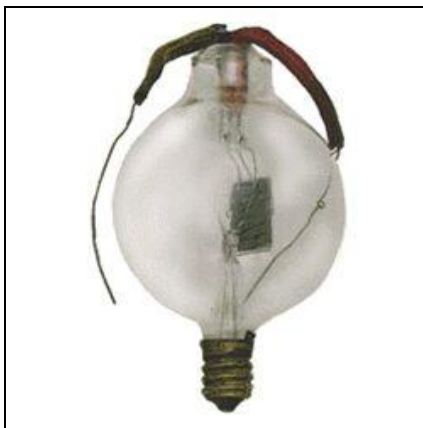
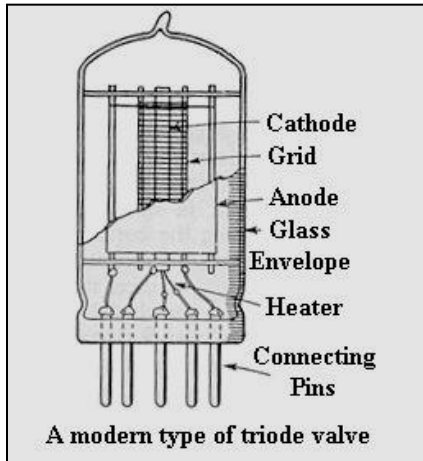

Vacuum Tube Advancements

- Over the years following the diode and triode vacuum tube inventions, several improvements were made to the design and more applications for it were devised:
 - Focus during World War I years was modifying the design for mass manufacturability
 - Newer materials to enhance performance (particularly in the filament)
 - Better methods for inducing and holding a vacuum in the tube
 - Repeatability in materials, manufacturing tolerances, testing, etc.
 - Multi-grid tube variations were invented (tetrode, pentode, hexode, heptode, octodes, etc.)
 - Special purpose tubes (low/high power, multi-use, fast warm-up, etc.)

Superhet Receiver

- Older Style Tuned Radio Frequency (TRF) Receiver

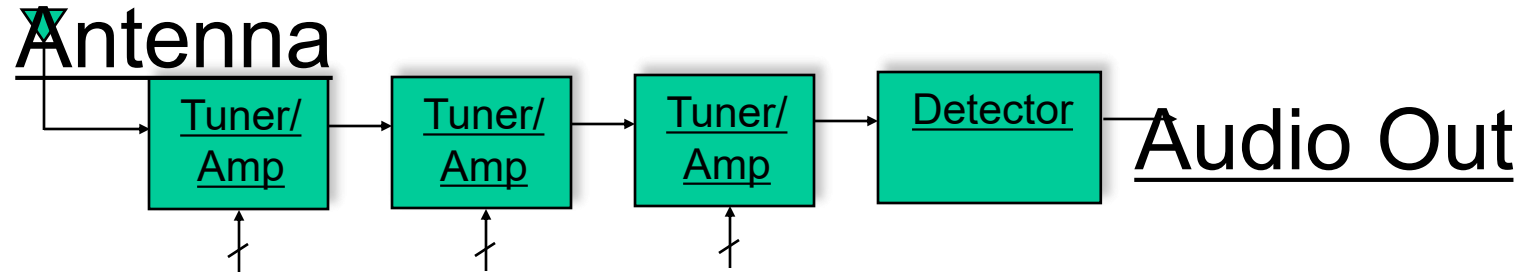

- Superhet Receiver

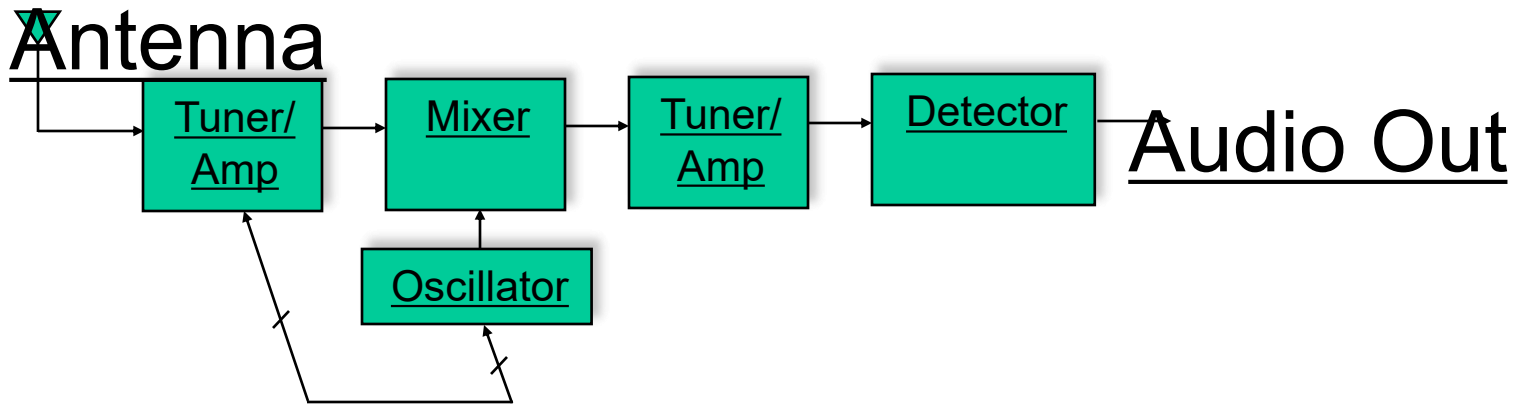

PPI Display

- The PPI Display provided a more useful picture of the radar field of view

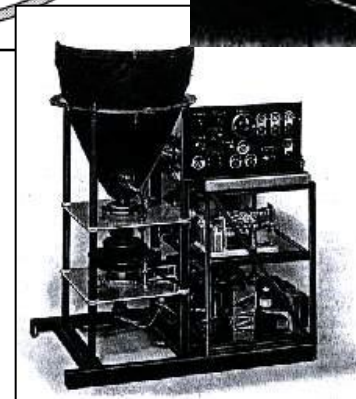
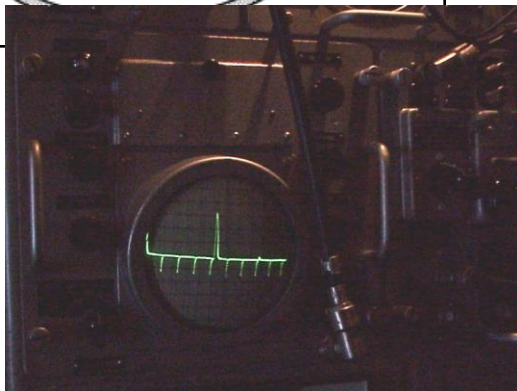
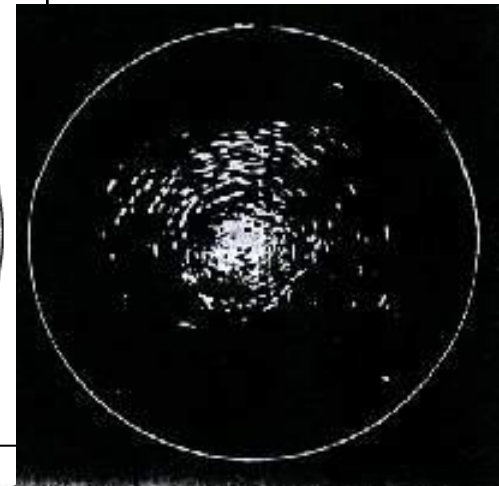
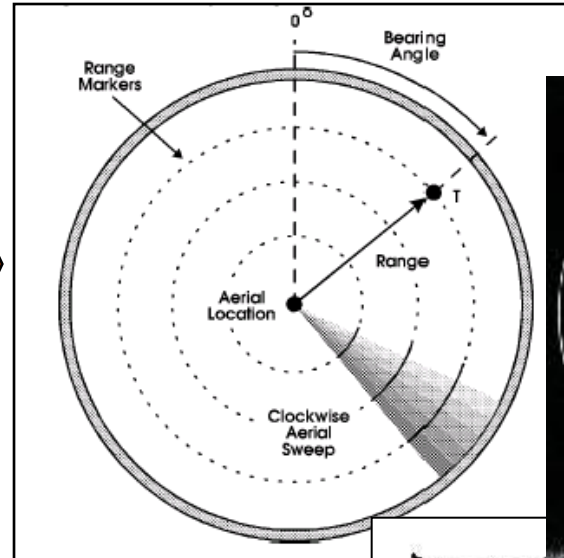
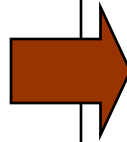
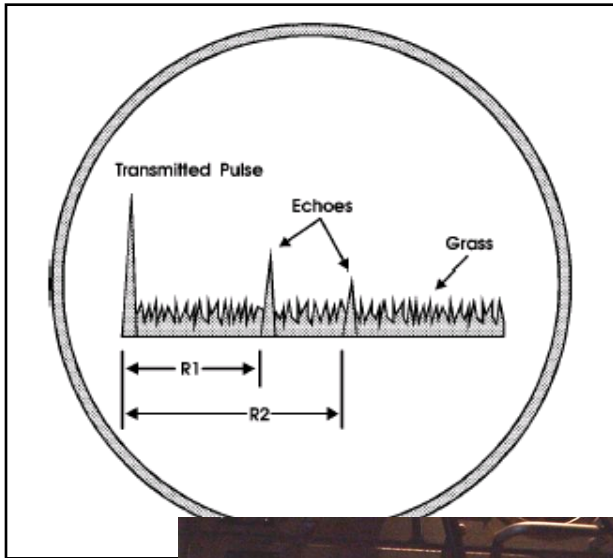

American Involvement in World War II

- Some British and American politicians recognized early on that the U.S. would likely get pulled into the war
- Sir Henry Tizard, a leader in development of the British CHAIN HOME and other radar programs, led a team of experts to meet with various American scientists and leaders
- The British shared a great number of technical secrets with the Americans, including the cavity magnetron
 - The U.S. quickly set up a new laboratory at MIT, the “Radiation Laboratory”
 - The Naval Research Laboratory and other groups also were recipients of the new technology
- By 1941, both Britain and the U.S. had begun to produce S-band (3 GHz) and later X-band (10 GHz) components and systems

Status Quo at End of WWII

- Radar had evolved from prototypes built in the mid-1930s to an explosion of different systems/applications by mid-1940s
- Microwave signal generation had become practical and advances in all areas (antennas, transmitters, receivers, displays, etc.) led to wide-spread use in communications and radar applications

Civilian Use of RADAR

- Following World WAR II, there was a lull in development of new technology for radar use
- Surplus military radars were put into service for civilian use, primarily as weather and air traffic control radars; later, radars were built specifically for those purposes
 - 1945 – First military radar (AN/APQ-13) is converted from ground mapping/bombing radar on B-29 bombers to storm warning radar; 30 systems installed on military bases
 - 1950 – US Civil Aeronautics Administration (precursor of the FAA) begins deployment of ASR-1 Airport Surveillance radars
 - 1954 – AN/APQ-13 is replaced by the AN/CPS-9, the first radar designed specifically for meteorological use
 - 1959 – WSR-57 weather surveillance radar is commissioned at the Miami hurricane forecast center



Semiconductor Development

- Following WWII, Bell Laboratories had a program focused on development of semiconductor devices to replace vacuum tubes in communications/electronics
- In 1947, the first transistor was invented by Dr. John Bardeen, Dr. Walter Brattain, and Dr. William Shockley
- In 1951, the first junction transistor is invented

Semiconductors affected radar development in two ways:

• Solid state devices could now be developed and utilized in

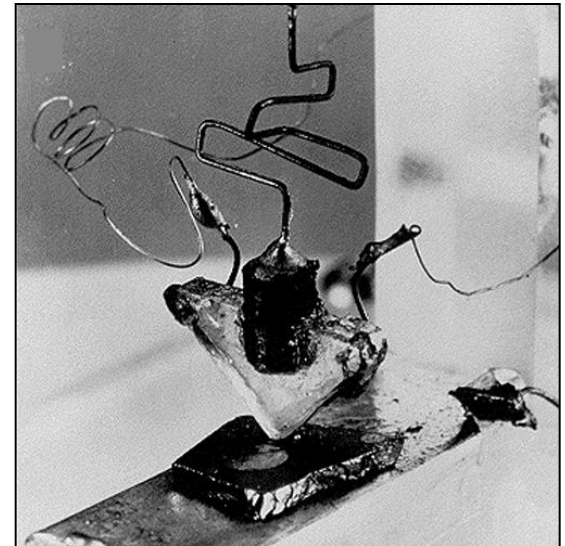

Modern RADAR Applications

- Following the development of semiconductor devices and digital computers, there was another mini-revolution in capabilities and applications of radar systems
 - Satellite radar for altitude mapping and surveillance
 - Pulse compression techniques for higher range resolution
 - Higher frequency, higher power, wider bandwidth components
 - Phased Array/Active Antennas
 - Advanced Doppler radar applications
 - Advanced meteorological measurements
 - Advanced Moving Target Indicators (MTI)
 - Synthetic Aperture Radar (SAR)

Satellite RADAR

- Early satellite radar focused on altitude mapping:
 - 1973 - Skylab S193 radar altimeter (1st in space); altitude/range resolution is 15 meters
 - 1974 - GEOS-3 launched, 1.9m resolution
 - 1978 - SEASAT launched, 0.5m resolution
 - 1985 - GEOSAT launched; 0.5m resolution
 - 1991 - ERS-1 launched; 0.5m resolution
 - 1995 - ERS-2 launched; 0.5m resolution

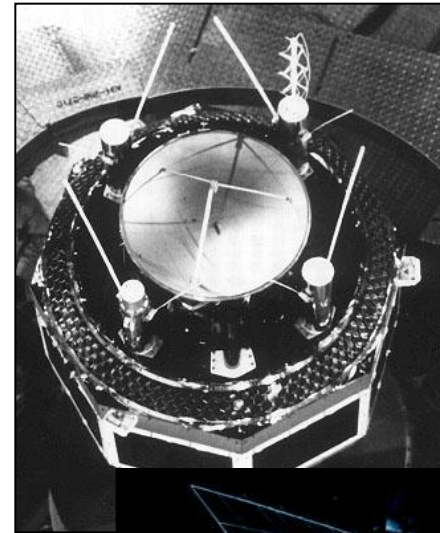

GEOS-3

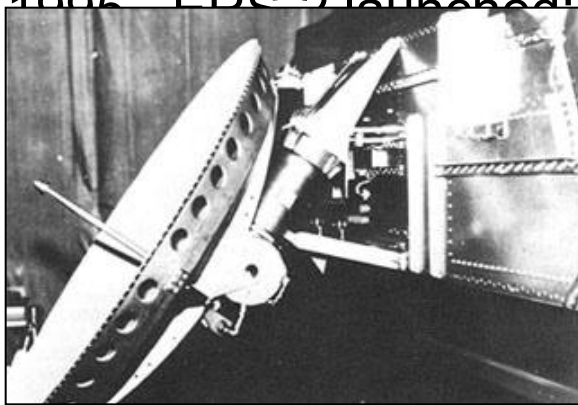

Skylab S193

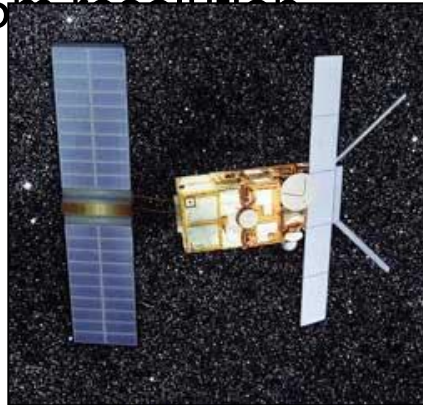

ERS Artist Concept

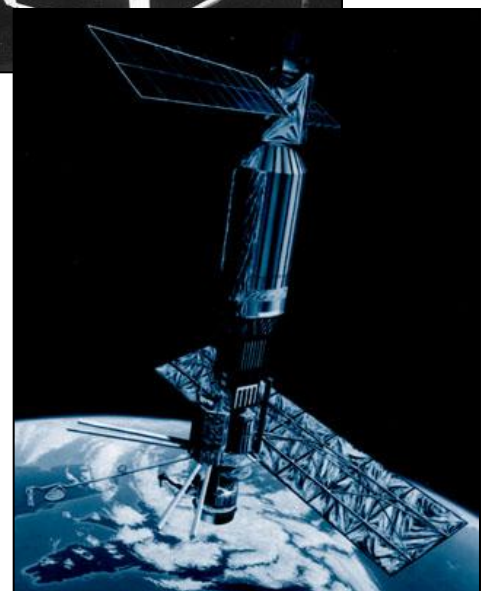

SEASAT Artist Concept

Satellite RADAR – Altitude Mapping

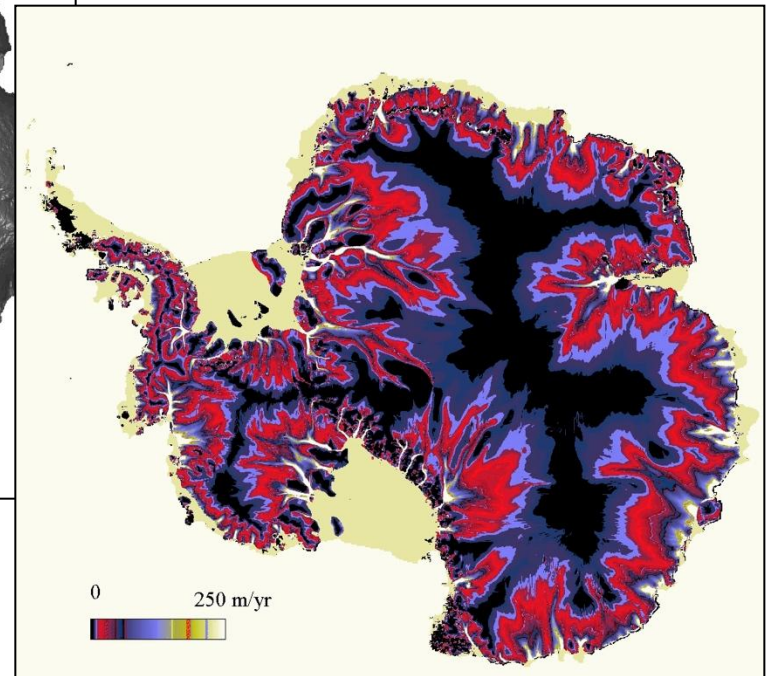
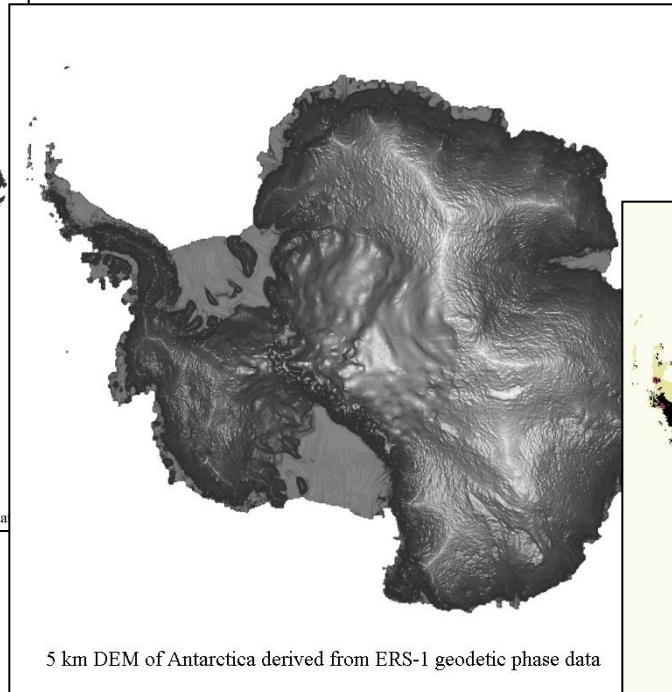
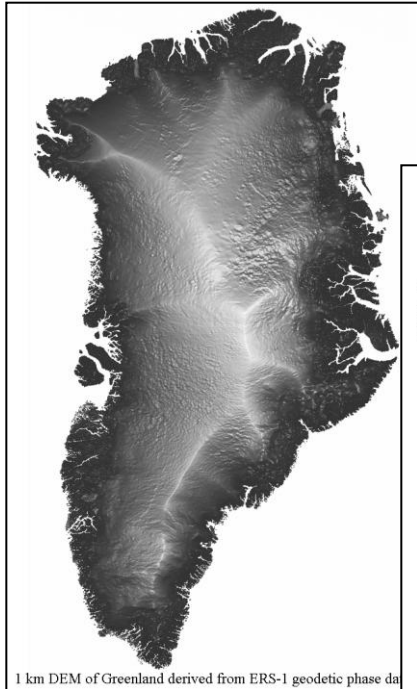

Pulse Compression Techniques

- Invented in the late 40s as a means to provide higher range resolution while maintaining good signal to noise performance of a radar system
- Older Style, Non-Pulse Compression System

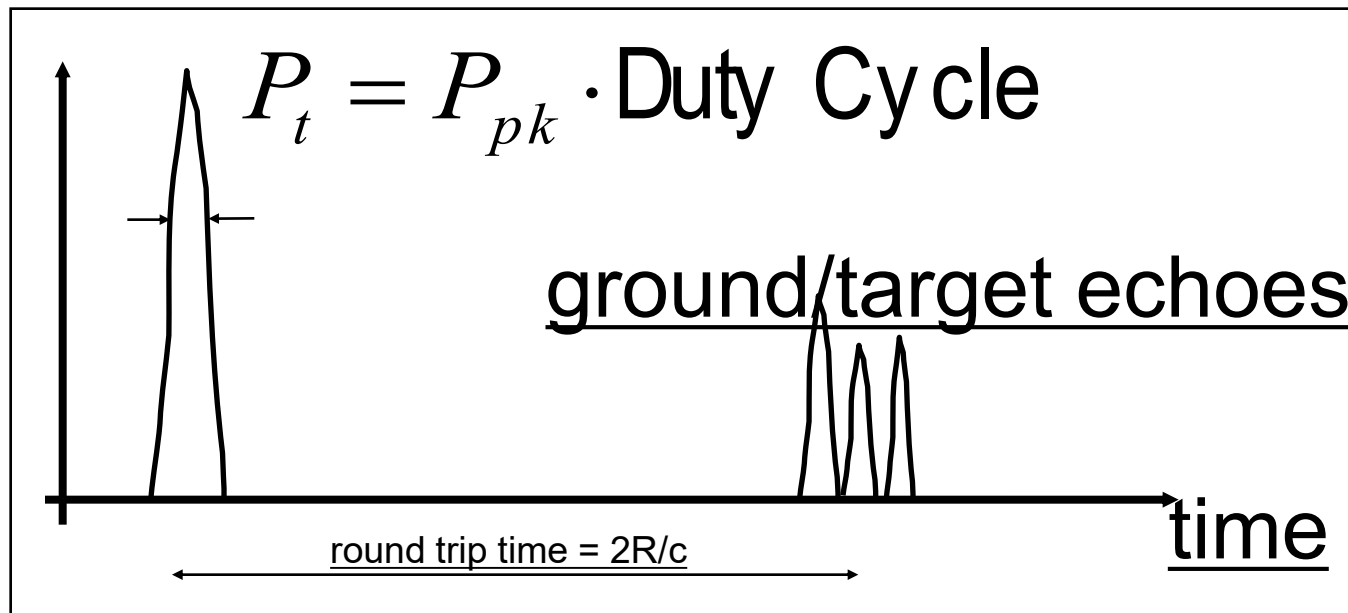

- Higher resolution means less average power transmitted (lower signal return strength and shorter range of operation)

Pulse Compression Techniques

- Pulse Compression System

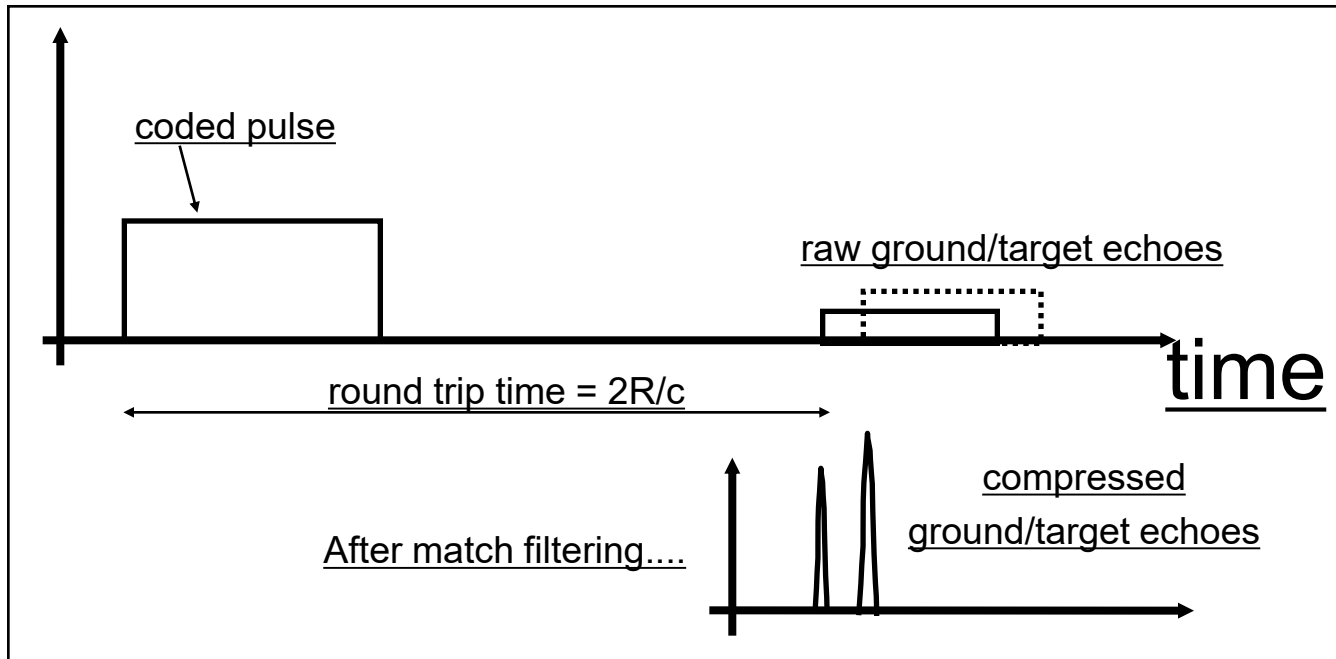
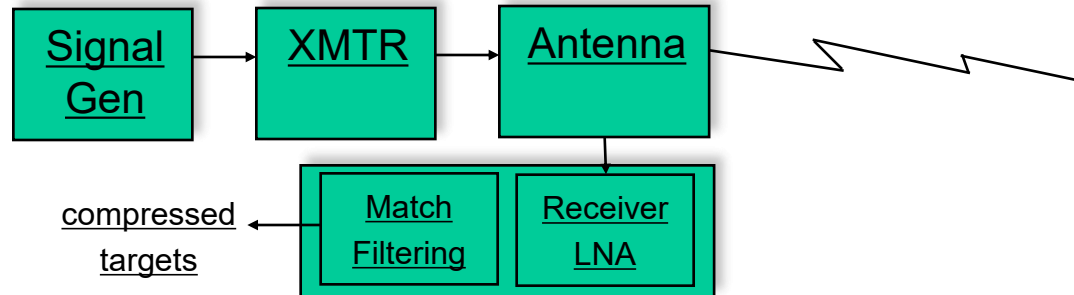

Pulse Compression Techniques

- In a pulse compression system, the resolution of the radar is given by the bandwidth of the transmitted pulse, not by its pulse width

$$\text{Range Resolution} \approx \frac{c}{2 \cdot BW_t}$$

- This allows very high resolution to be obtained with very long pulses (higher average transmit power/longer operating range)
- Popular pulse compression techniques:
 - Binary phase coding of the pulse
 - Linear FM modulation of the pulse (“chirp” radar)
 - Stepped frequency waveform

Modern Microwave Components

- New materials, new techniques for building microwave components, transmission line improvements, monolithic microwave integrated circuits (MMICs), etc. have provided improvements in terms of sensitivity, bandwidth, power, etc. in all areas

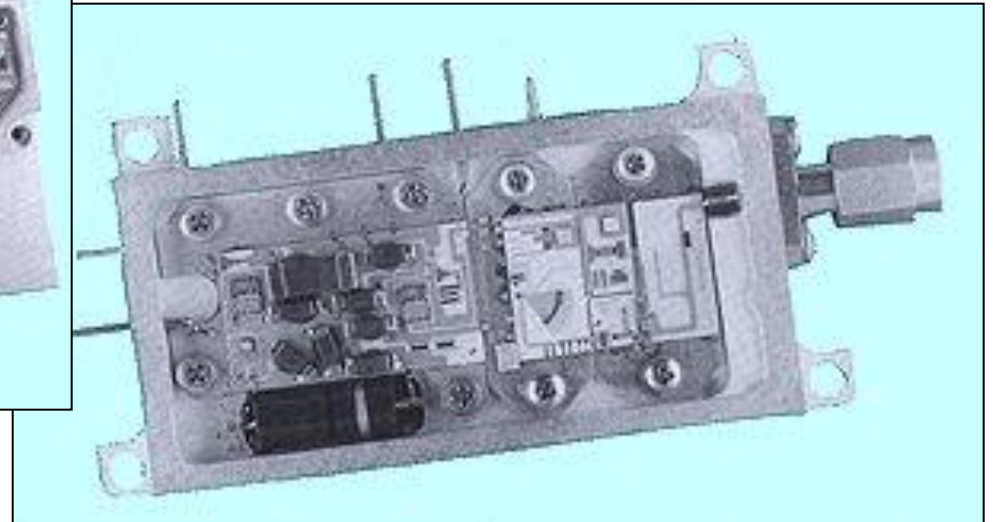
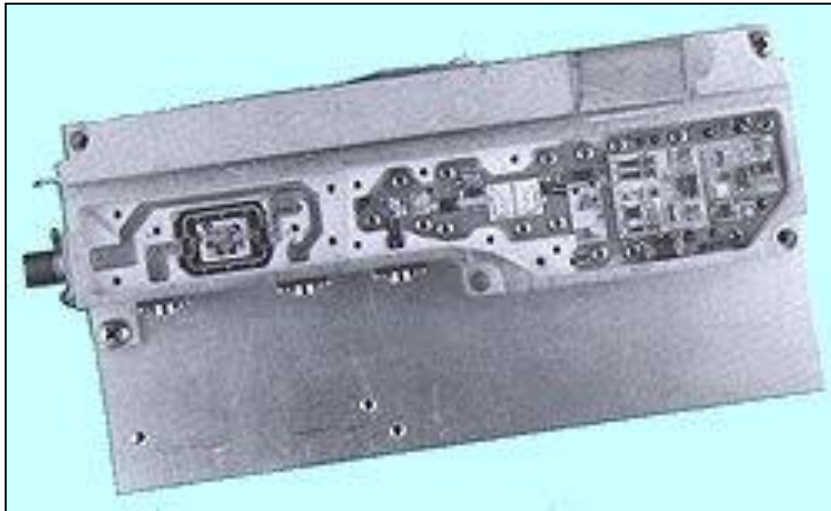

Phased Array/Active Antennas

- Typical Flat Plate Antenna Array

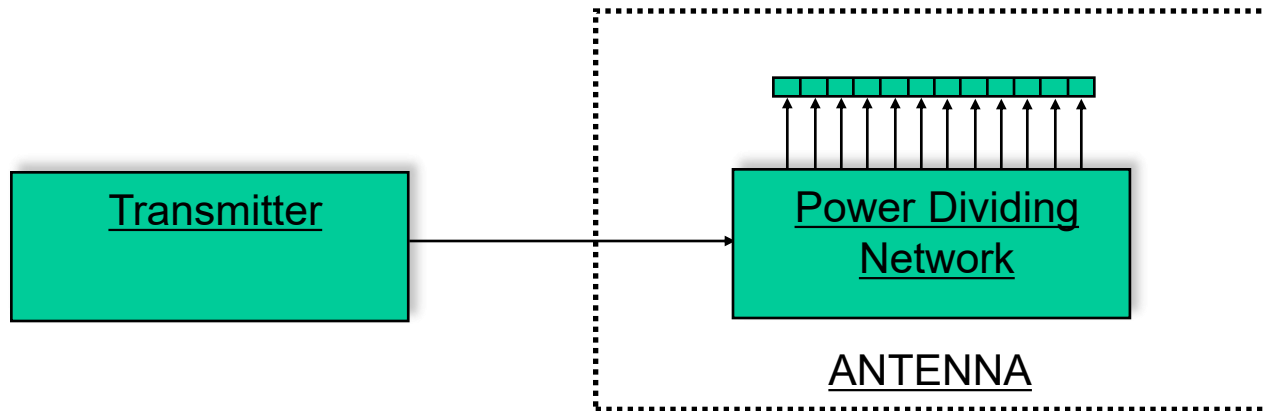

- Electronically Steerable Array (ESA)

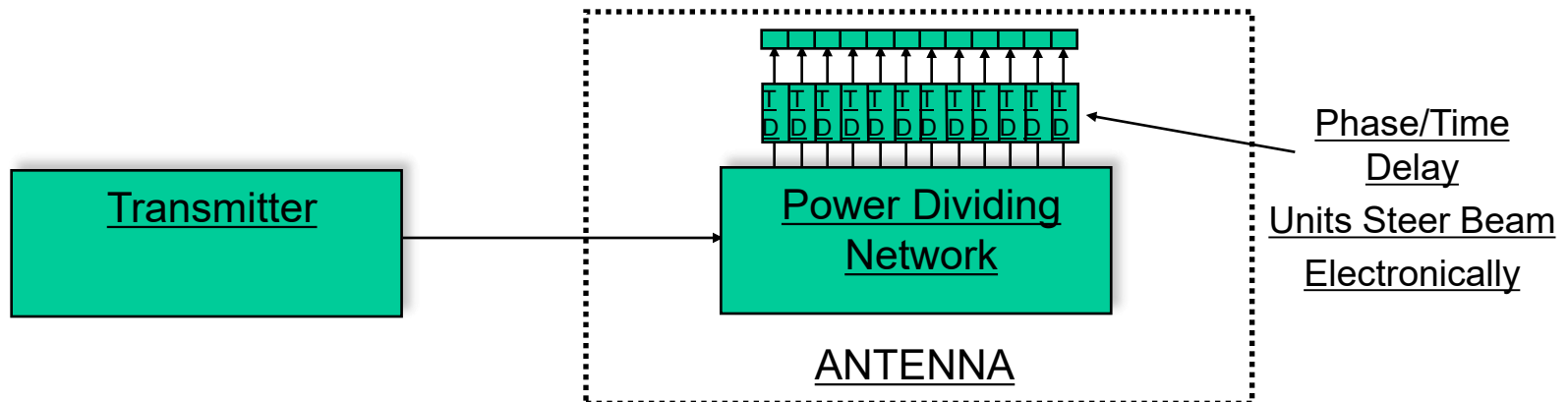

Phased Array/Active Antennas

- Active Antenna
 - Build-up of Transmit/Receive (T/R) modules which integrate a low-power (~ 1 Watt) solid state transmitter, a low-noise amplifier receiver, and a time-delay and/or phase shifter

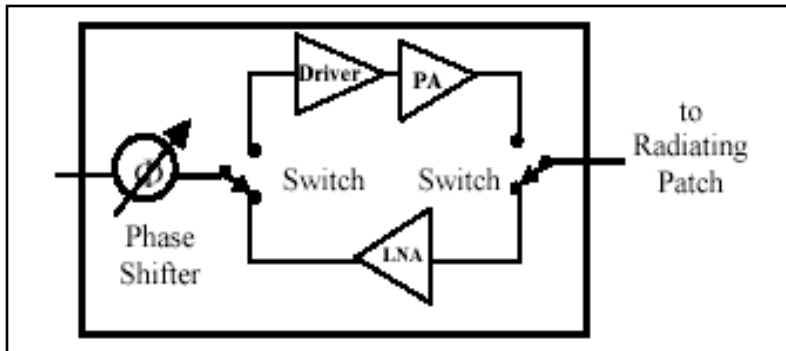

T/R Module Block Diagram

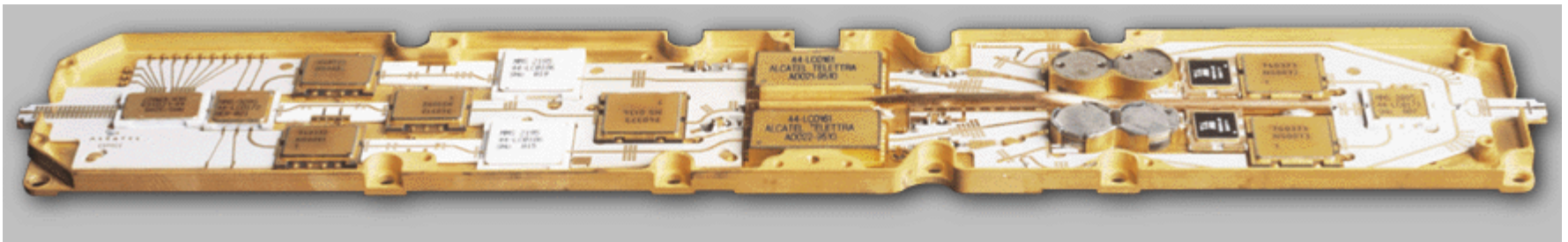
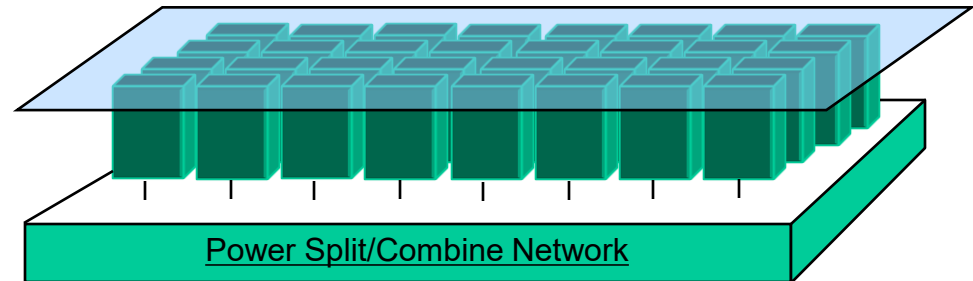

Phased Array/Active Antennas

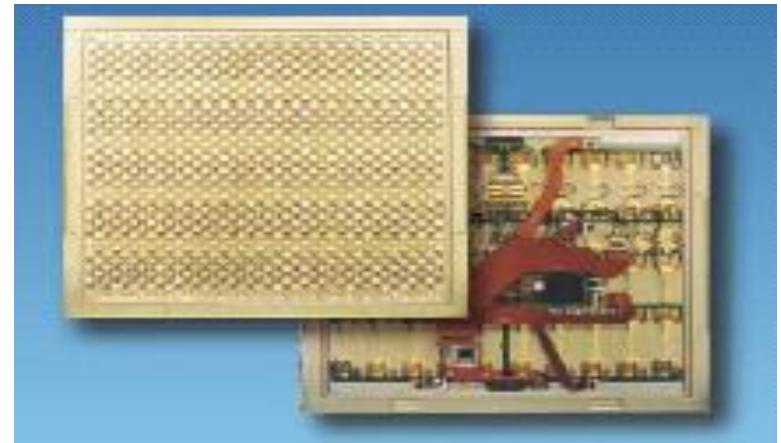
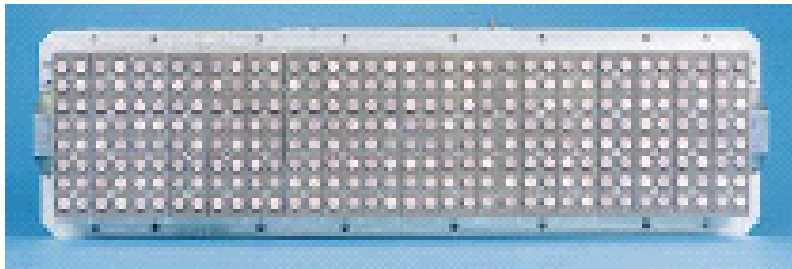

Modern Doppler RADARs

- Doppler effect – First presented by Andreas Christian Doppler in 1842

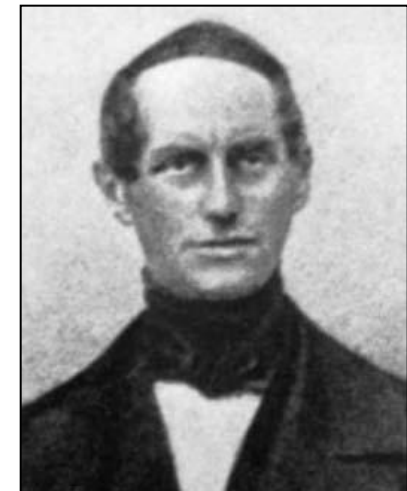
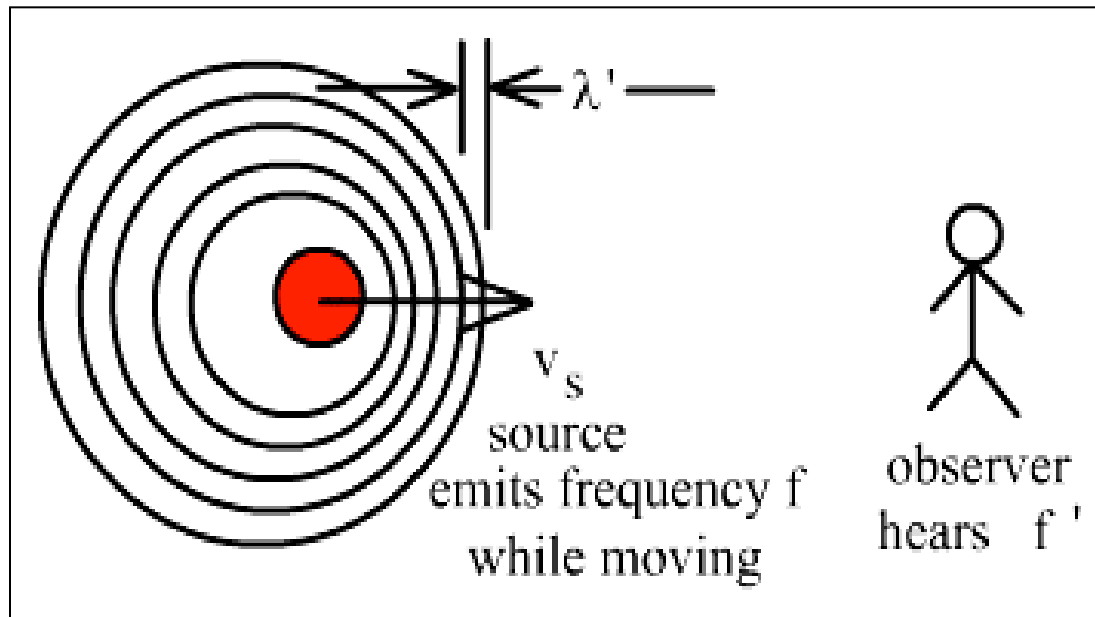

Andreas Doppler

Modern Doppler RADARs

- The Pulse Doppler RADAR:

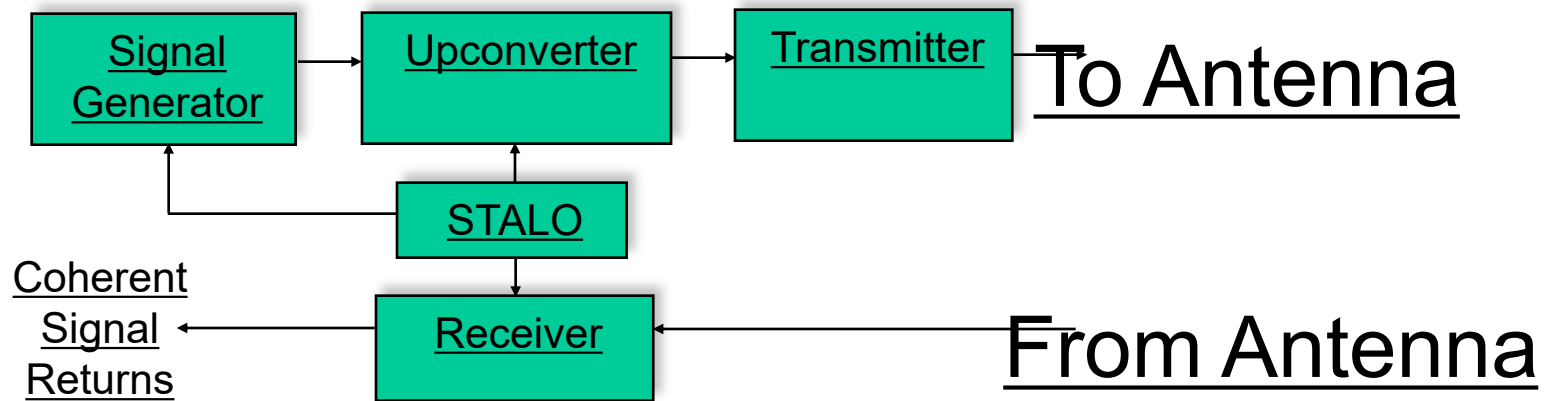

- All timing and operating frequencies are derived from a single source frequency
- The change in phase of a target return from pulse to pulse is a measure of the relative motion between the radar and the target

Applications of Pulse Doppler RADARs

- Radar Guns



Applications of Pulse Doppler

RADAR

- Meteorological RADAR

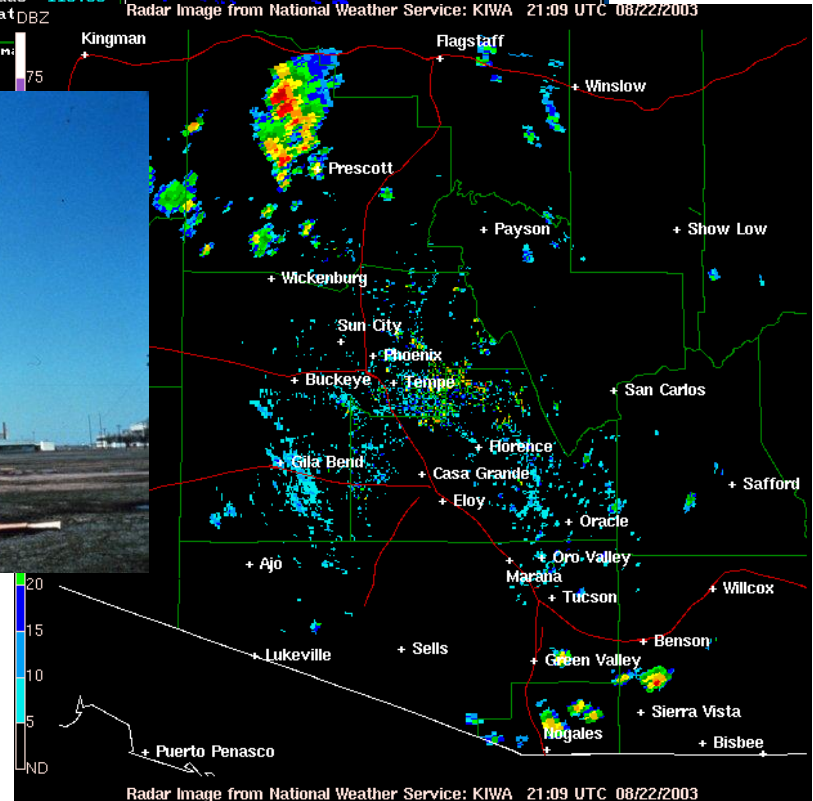
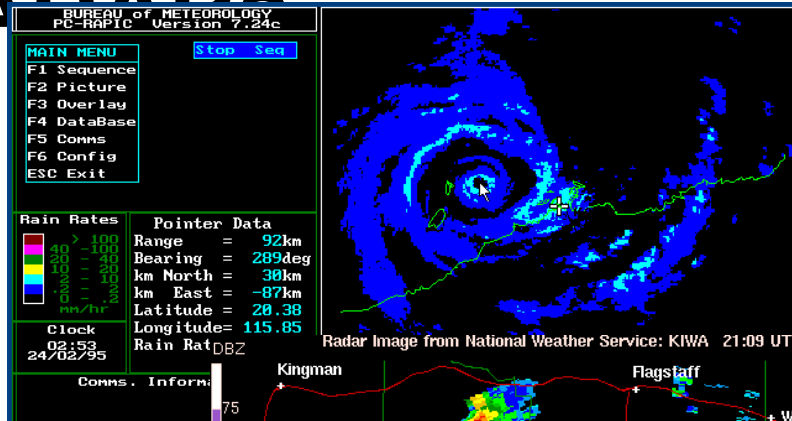
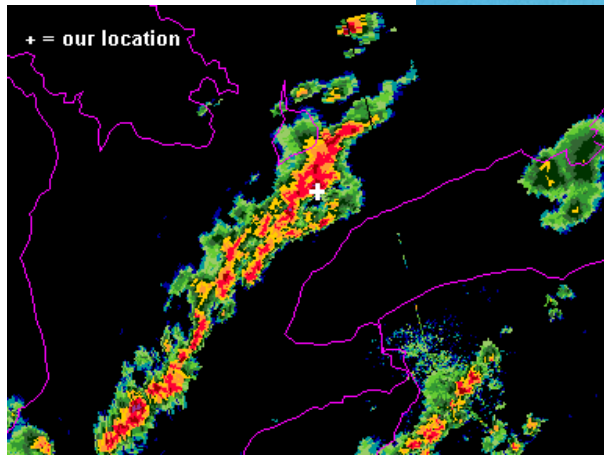
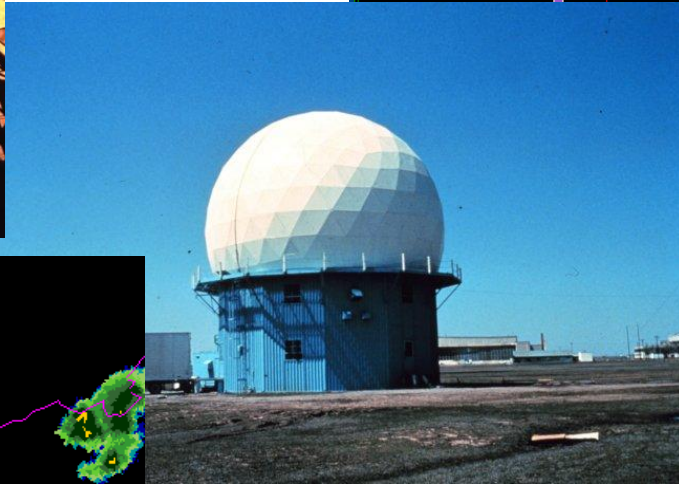
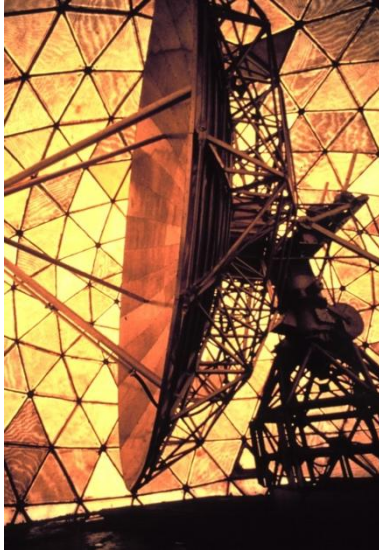

Applications of Pulse Doppler RADAR

- MTI Radar

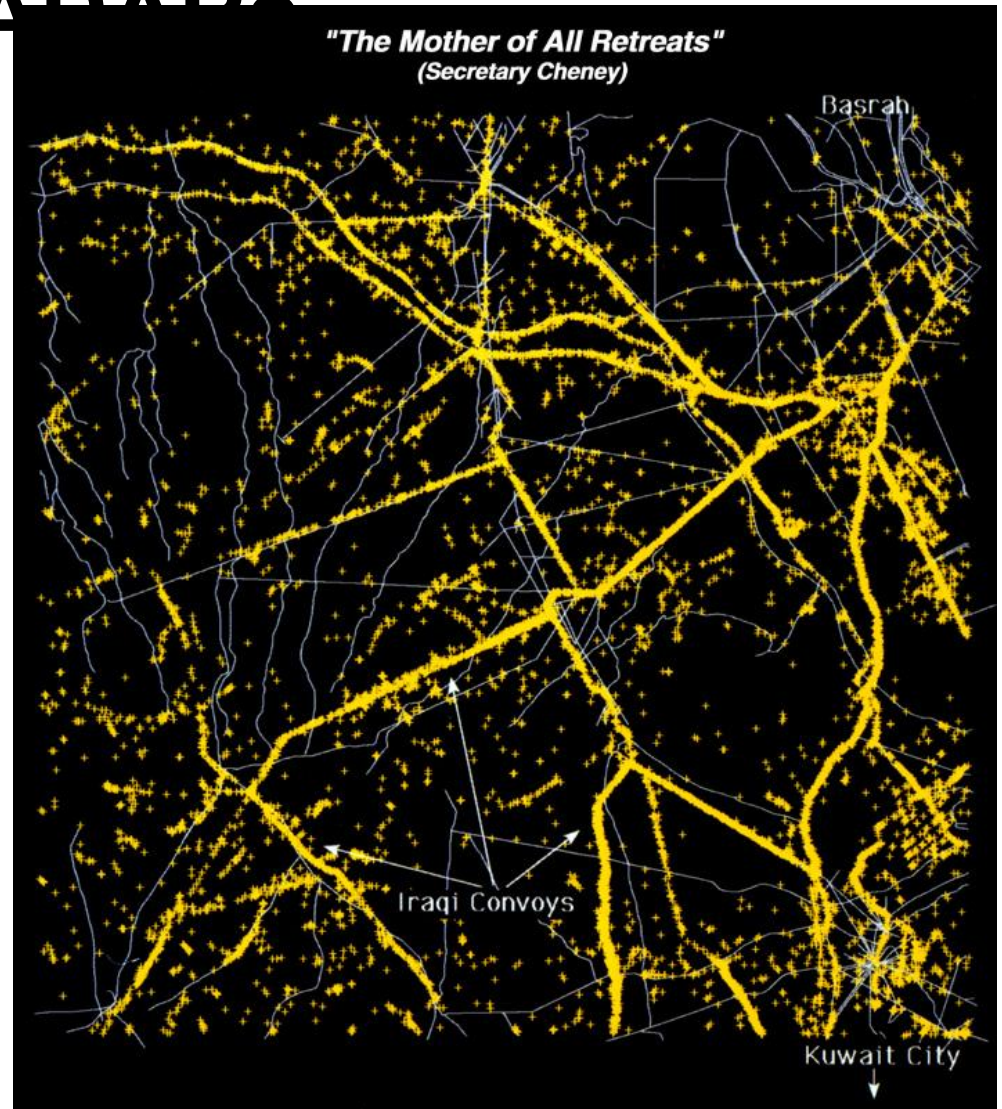

Applications of Pulse Doppler

RADARs

- Synthetic Aperture Radar (SAR)



Applications of Pulse Doppler RADARs

- Synthetic Aperture Radar (SAR)

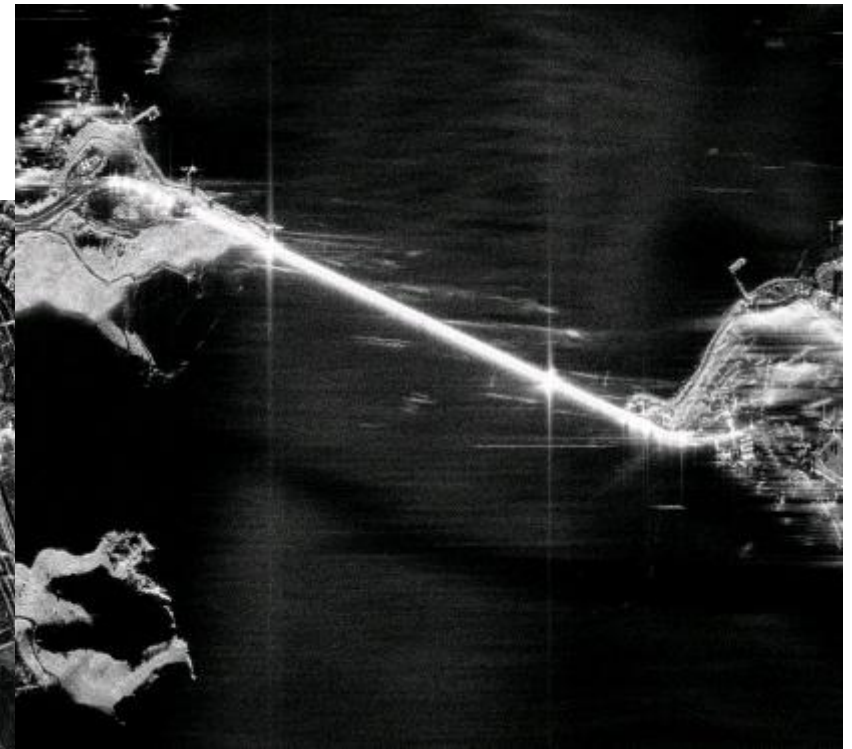

Sept 1939: Europe in WWII

- Britain fighting since Sept ' 39
- Chain Home Radar & the Battle of Britain

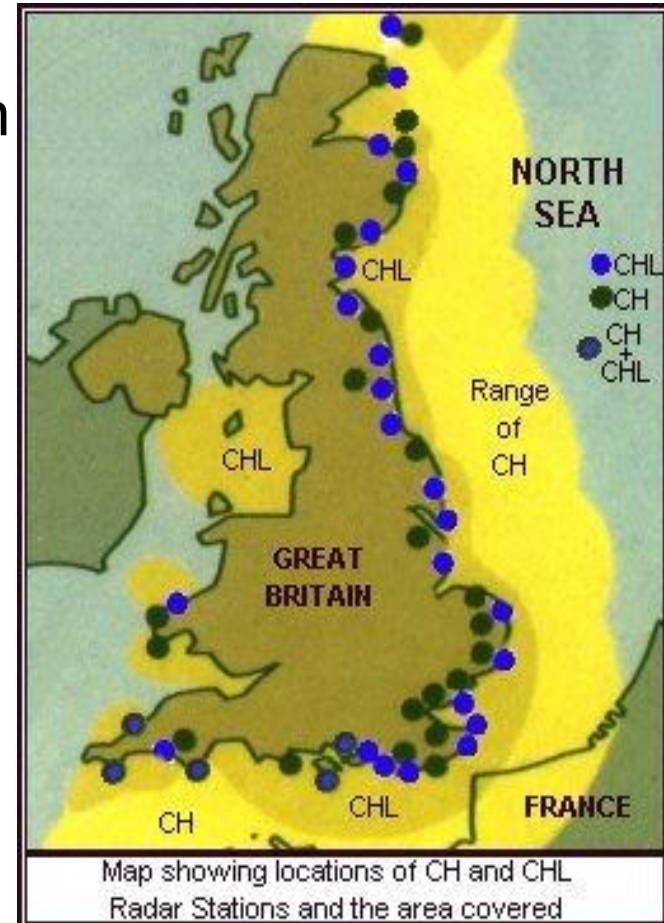

Dec 7th 1941: America Enters WWII

- Britain fighting since Sept '39
- Soviets fighting massive land/air battles since June '41
- Allies incapable of landing in Western Europe for 2+ years
- Decide that
 - priority was to win in Europe vs Pacific
 - destroy German war fighting capacity from the air until they can invade



Strategic Bombing of Germany

The Combined Bomber Offensive

- British bombed at Night
 - Area Bombing
 - Lancaster's
 - Halifax
 - Flew at 7 - 17 thousand feet
- The American's by Day
 - Precision Bombing
 - B-17's
 - B-24's
 - Flew at 15 - 25 thousand feet





Early Warning Radar Range

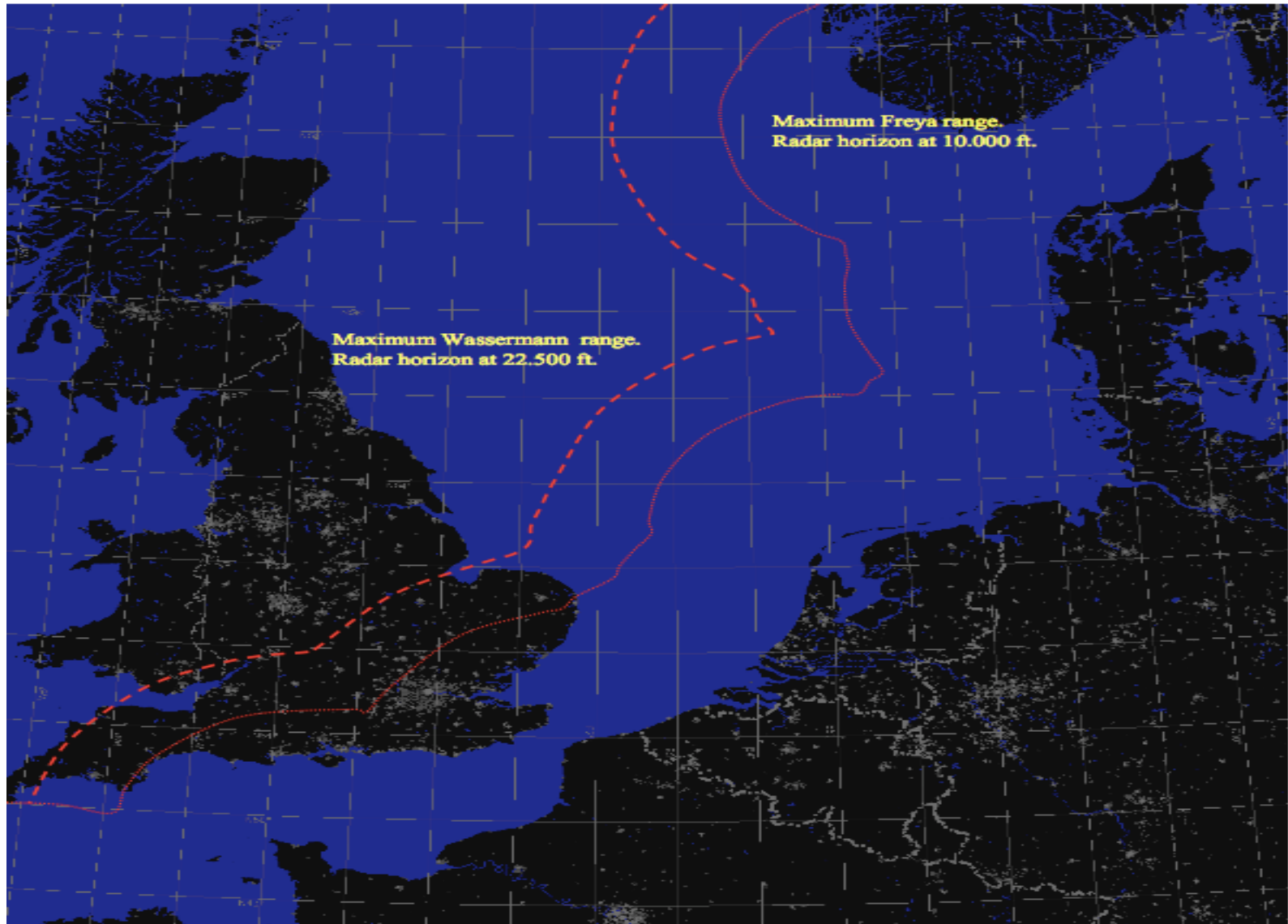

Strategic Bombing of Germany

March 1943: The Combined Bomber Offensive

“Your primary objective will be the progressive destruction and dislocation of the German military, industrial and economic system and the undermining of the morale of the German people to a point where their capacity for armed resistance is fatally weakened.”

The German Air Defense System

The Kammhuber Line

- Integrated *Electronic* air defense network
 - Covered France, and into Germany
- Protection from British/US bomber raids
 - Warn and Detect
 - Target and Aim
 - Destroy

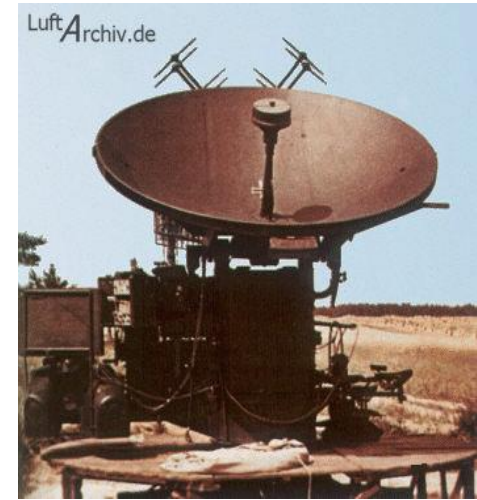

The German Air Defense System

The Kammhuber Line

- Integrated *Electronic* air defense network
 - Covered France, the Low Countries, and into northern Germany
- Protection from British/US bomber raids
 - Warn and Detect
 - Target and Aim
 - Destroy

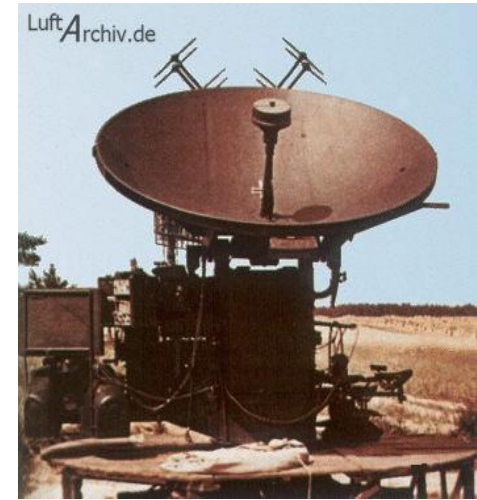

British/American Air War in Western Europe

28,000 Active Combat Planes

40,000 Allied planes lost or damaged beyond repair:
(46 000 planes lost by the USSR in the East)

160,000 Americans and British killed,
wounded or captured

The Bombing Effort - Summary

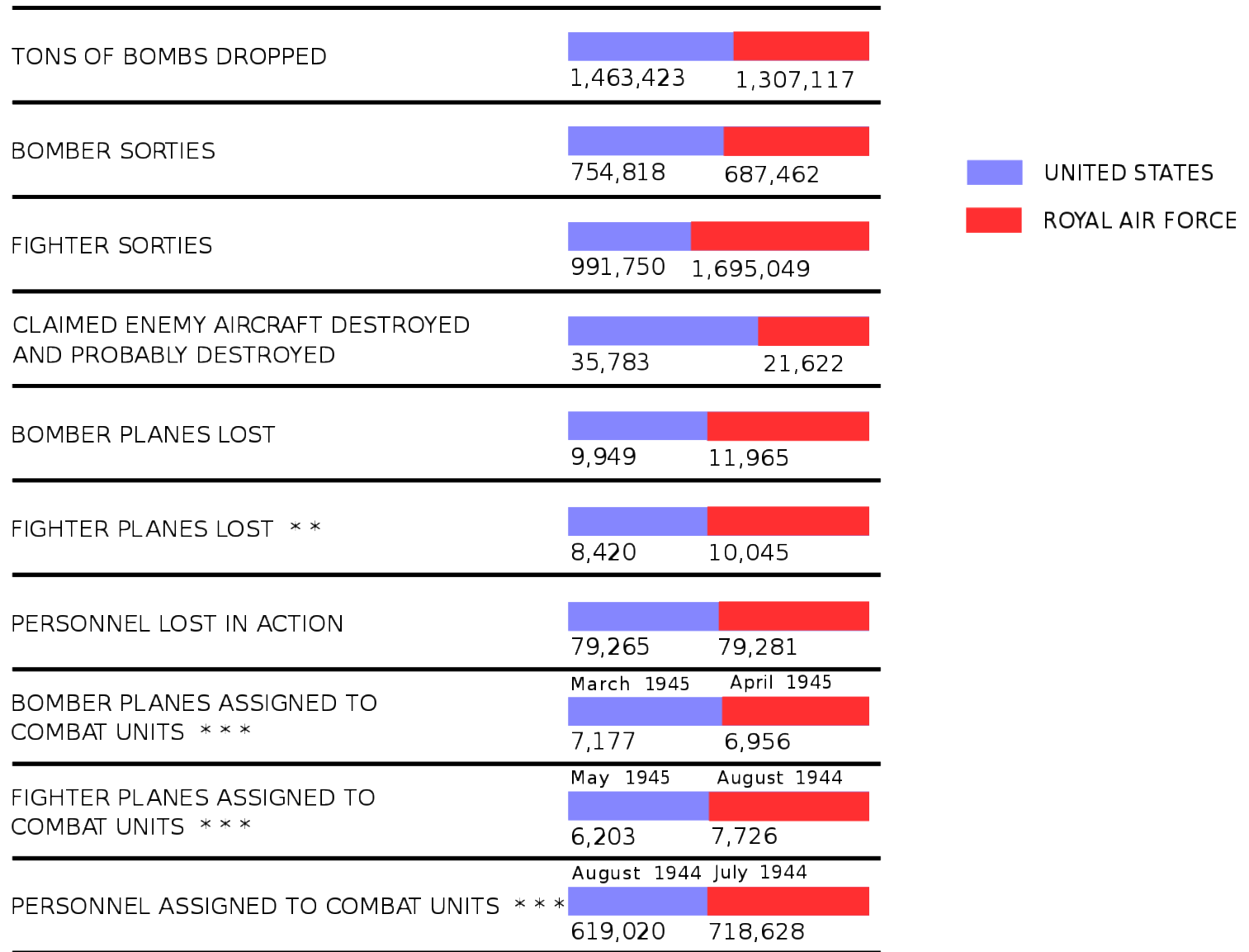

Early Warning Radars in Occupied France

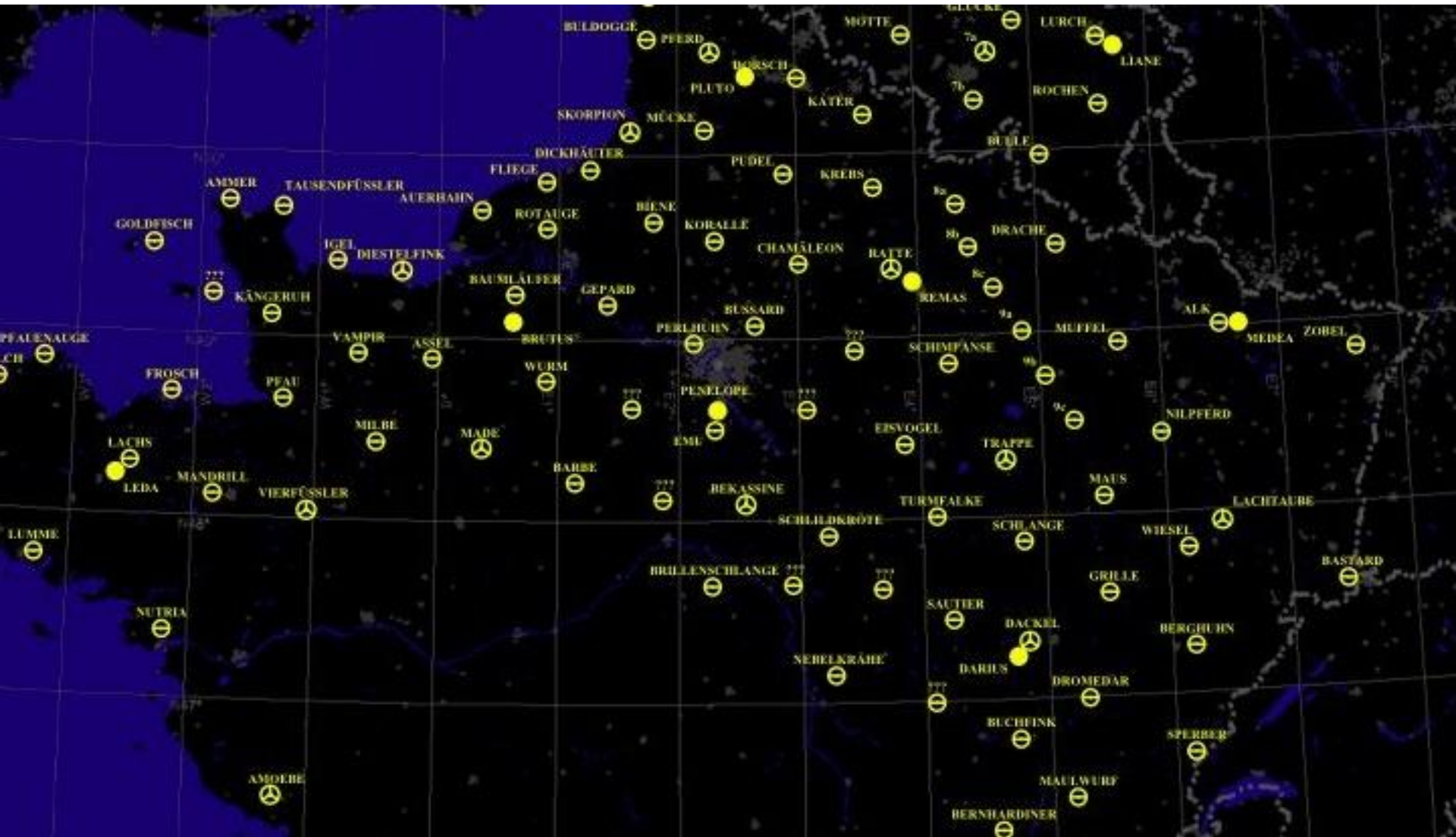

Mammoth Early Warning Radar

- 200 mile range
- 100' wide, 33' high
- 1st phased-array radar
- Operational 1942
- **20 built**

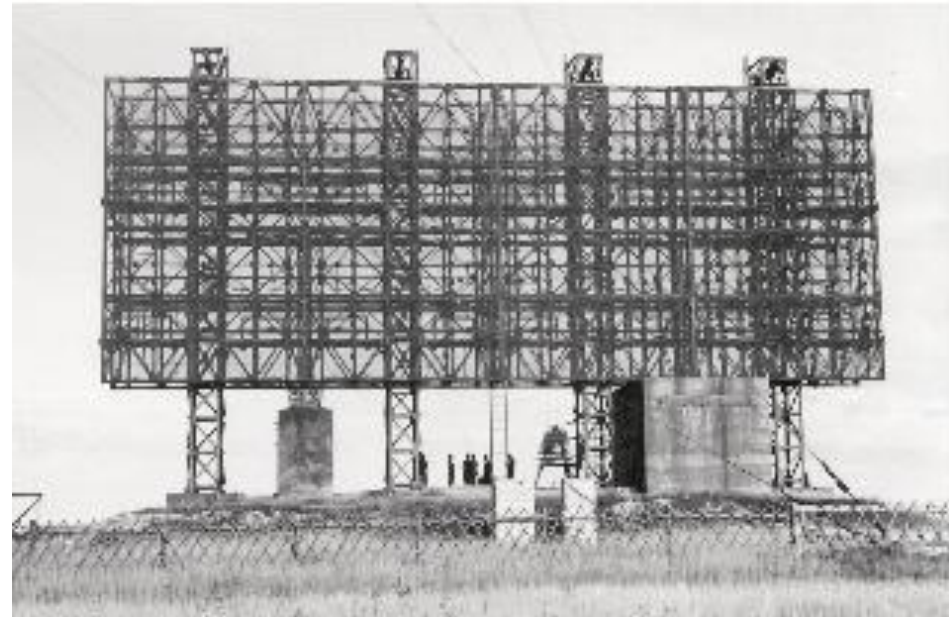

Mammoth Early Warning Radar

- 200 mile range
 - 150 MHz, 200KW, PRF 500hz, PW 3 μ s, accuracy 0.5 $^{\circ}$
- 100' wide, 33' high
- 1st phased-array radar
- Operational 1942
- **20 built**

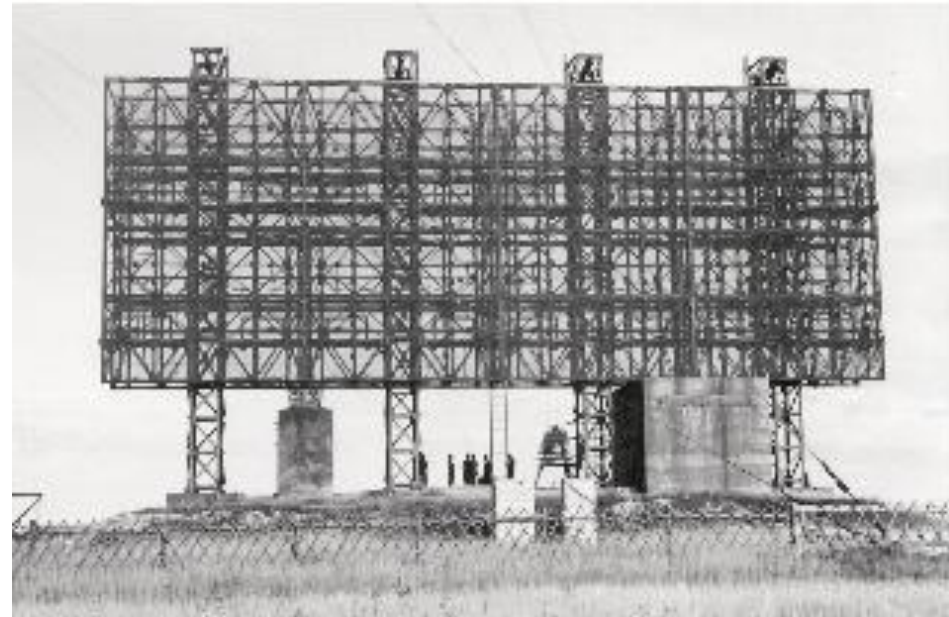

Wasserman Early Warning Radar

- 150 mile range
- Backbone of the German early warning network
- Steerable tower 190'
- Operational 1942
- **150 built**

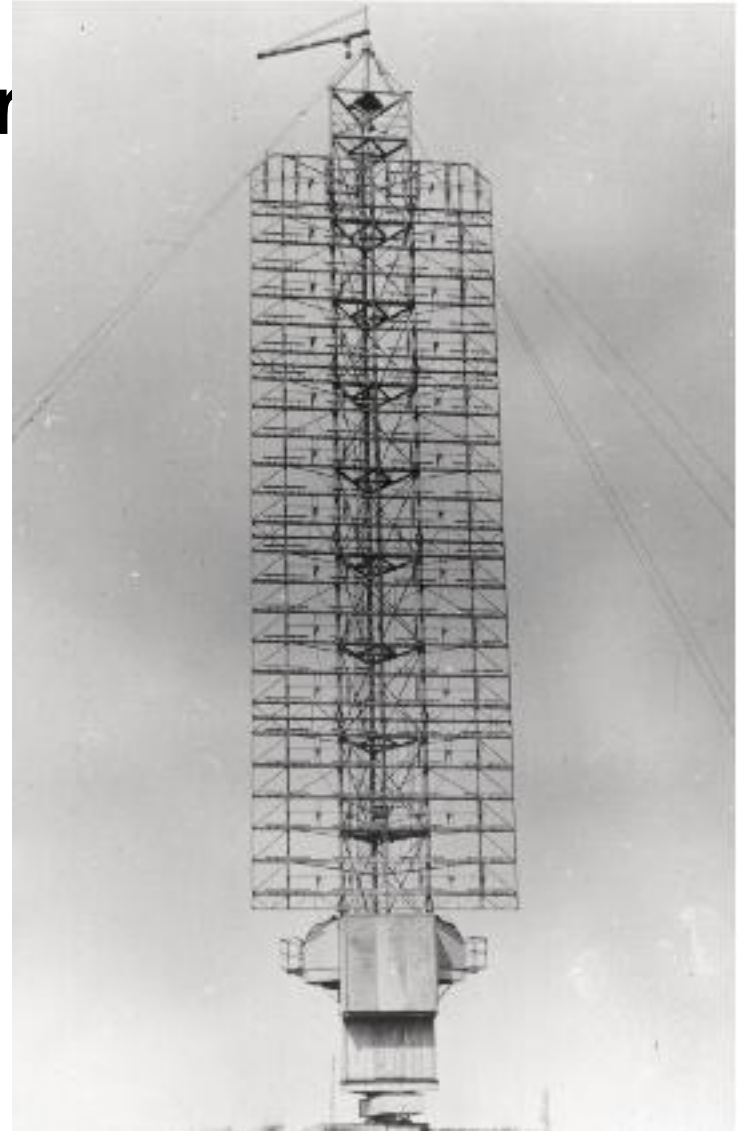

Wasserman Early Warning Radar

- 150 mile range
 - 150 MHz, 100KW, PRF 500hz, PW 3 μ s, accuracy 0.25°
- Backbone of the German early warning network
- Steerable tower 190'
- Operational 1942
- **150 built**

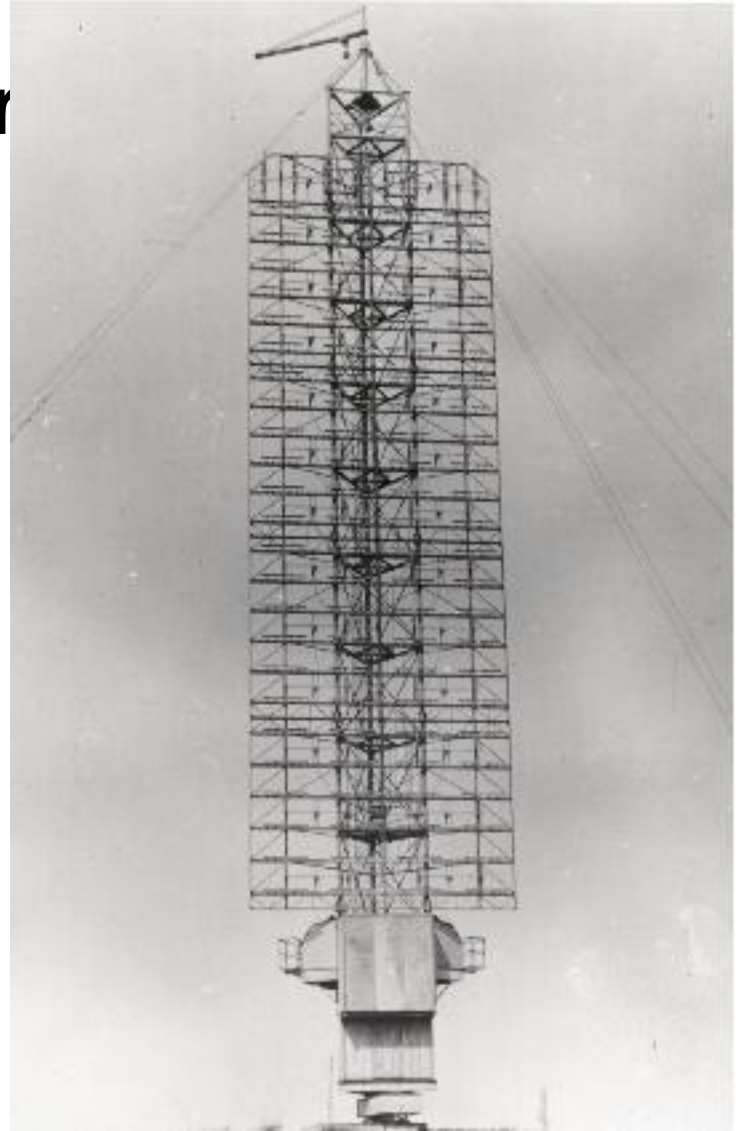

Wasserman Early Warning Radar Sites

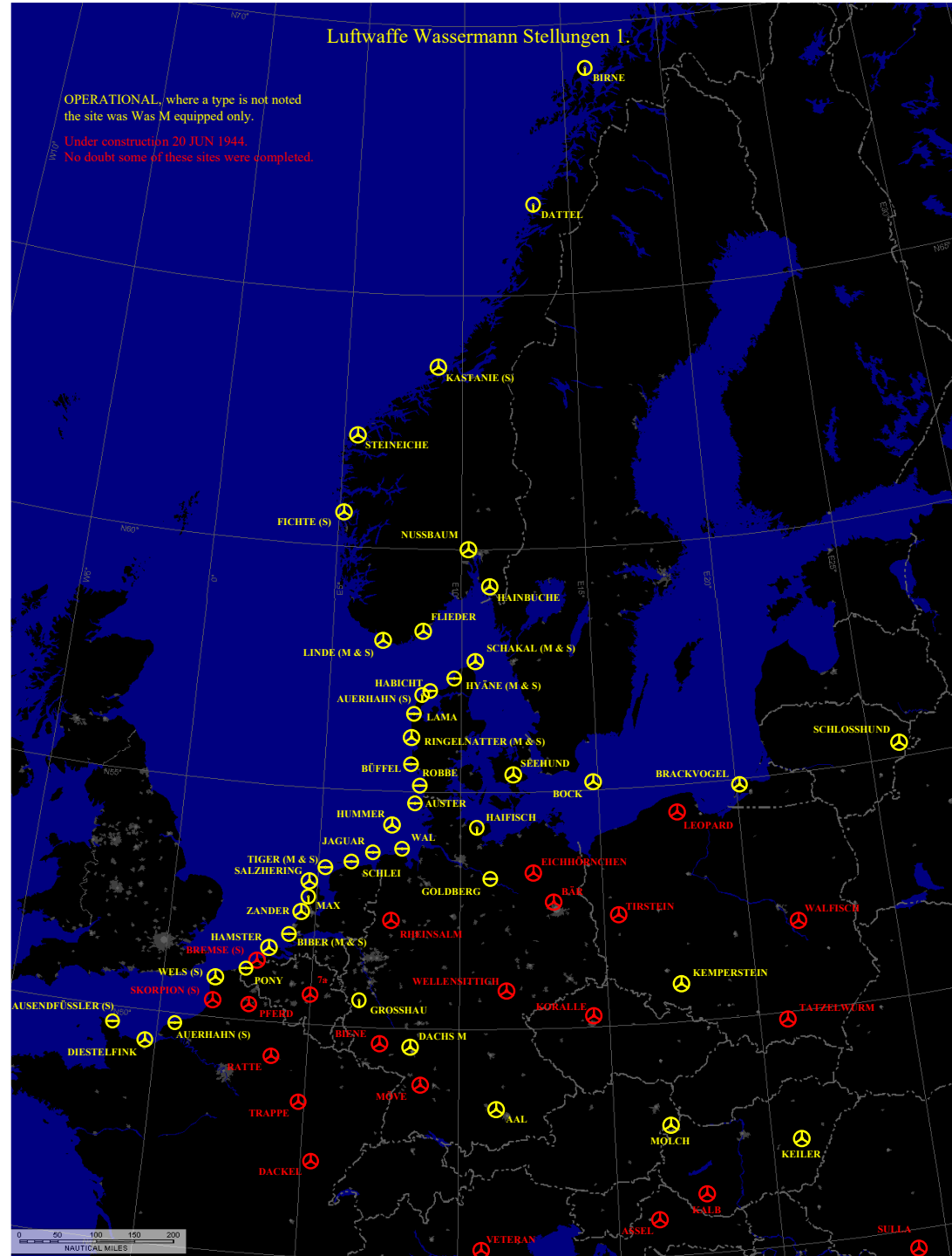

Jagdschloss Early Warning Radar

- Best early warning radar
- 180 mile range
- 360° rotation at 4 rpm,
- Remote radar display via microwave link
- Operational 1944
- **80 built**

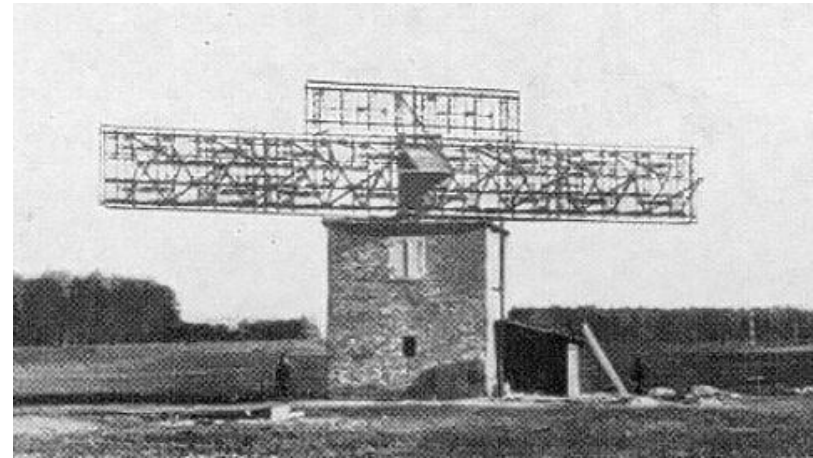

Jagdschloss Early Warning Radar

- 180 mile range
 - 120-157 or 156-250 MHz, 300KW, PW 1 μ s, PRF 500hz
- Best early warning radar
- 360° rotation at 4 rpm,
- Remote PPI display via microwave link
- Operational 1944
- **80 built**

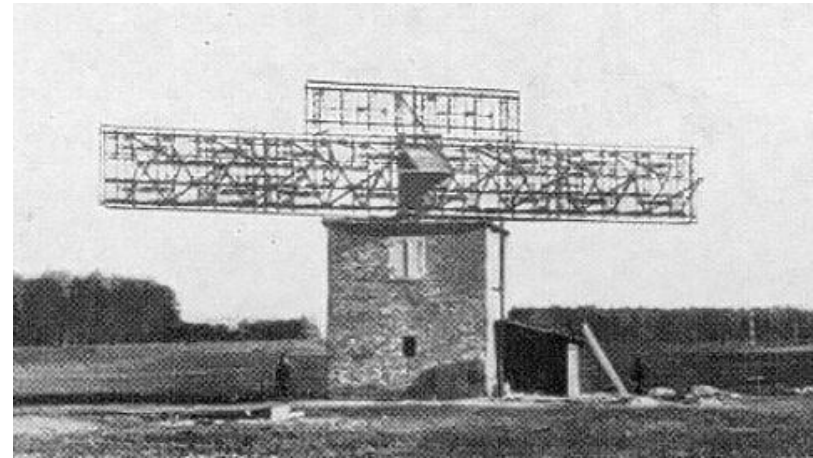

Himmelbelt Local Air Defense Network

- Box ~30 x 20 miles
- Integrated network of radars, flak, fighters, searchlights



Himmelbelt

Radar Order of Battle

- Freya
 - Early warning radar
 - Used for local defense
 - Detect allied bombers
 - Cue other weapons

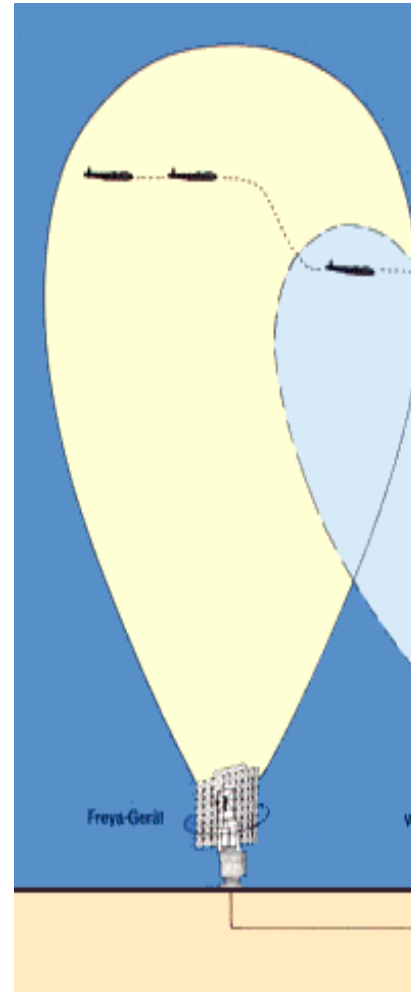

Himmelbelt Radar Order of Battle

- Freya
 - early warning radar
 - detect allied bombers

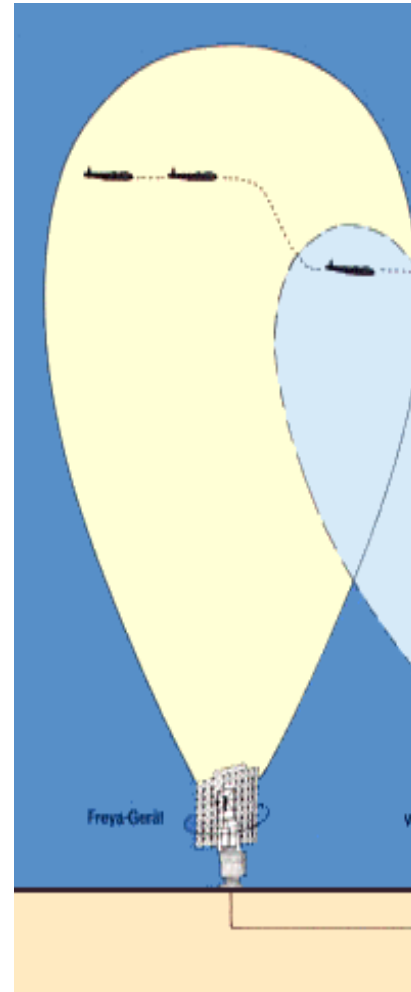

Himmelbelt

Radar Order of Battle

- Freya
 - early warning radar
 - detect allied bombers
- Giant Wurzburg
 - Ground Controlled Intercept radar
 - direct fighters to bombers
 - fighters could then intercept with their on-board radar

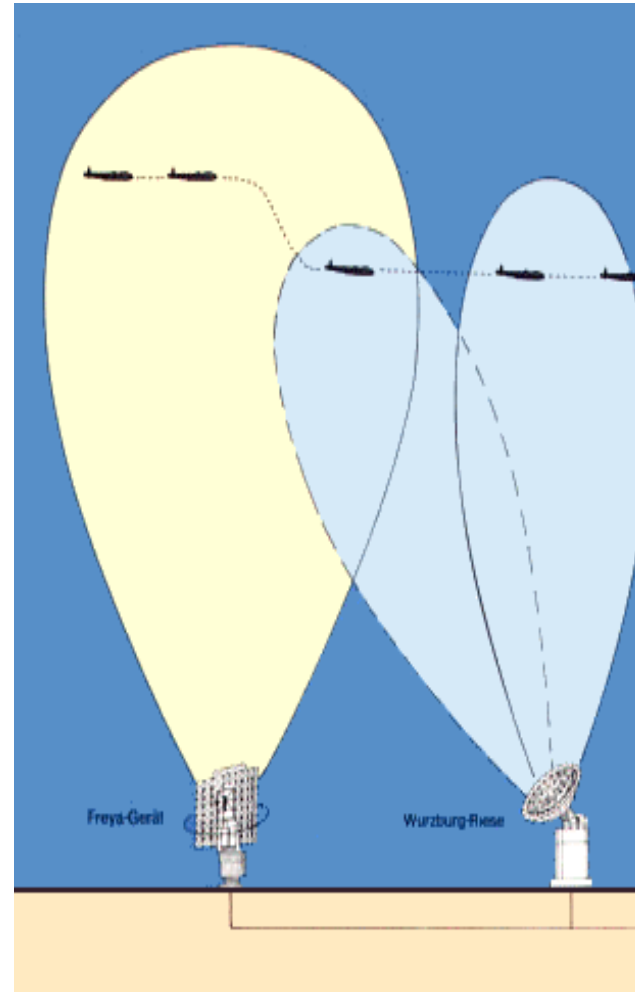

Himmelbelt

Radar Order of Battle

- Freya
 - early warning radar
 - detect allied bombers
- Giant Würzburg
 - Ground Controlled Intercept radar
 - direct fighters to bombers
 - fighters could then intercept with their on-board radar
- Lichtenstein BC & SN2
 - Airborne radar on German nightfighters

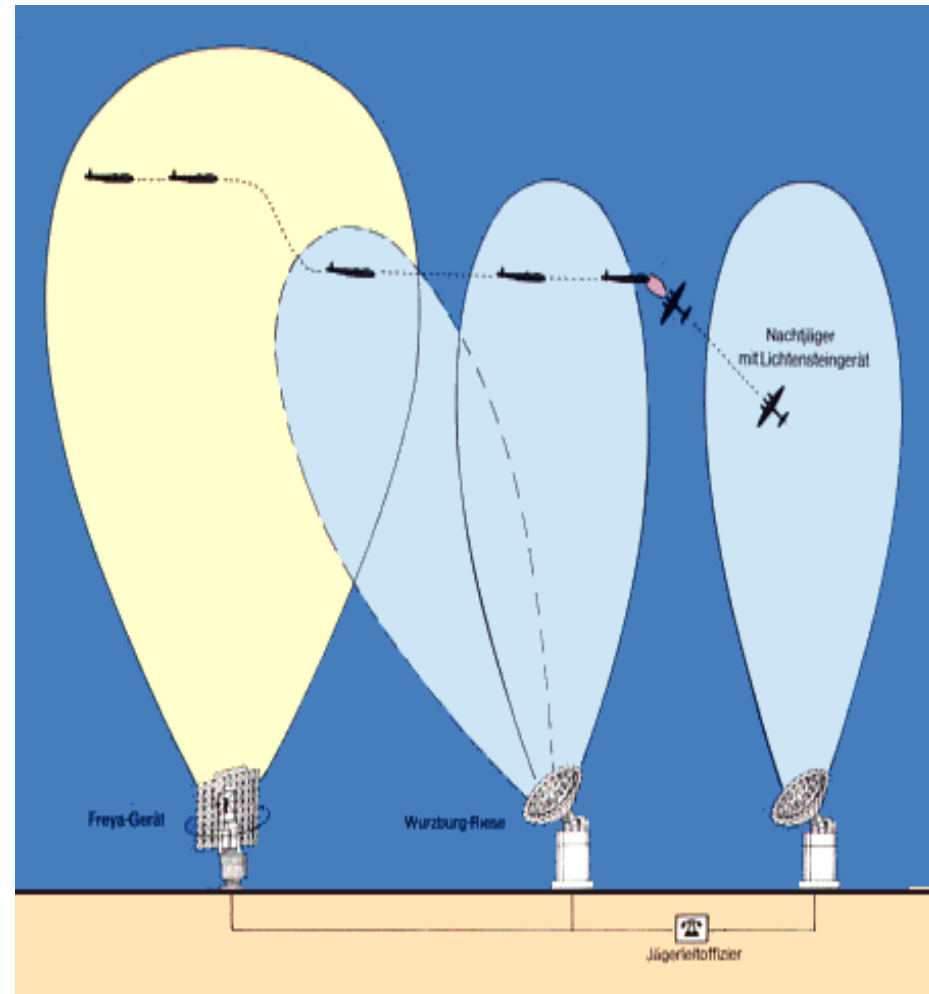

Freya

Early Warning Radar

- 60-120 mile range
- Steerable and mobile
- **Over 1000** deployed

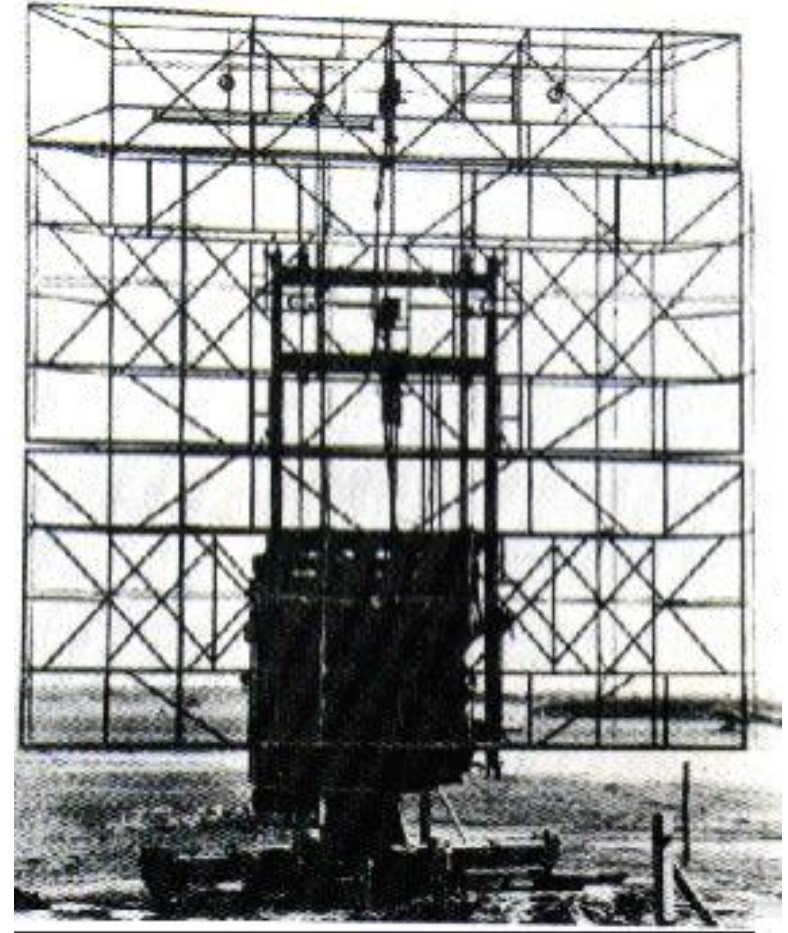

Freya

Early Warning Radar

- 60-120 mile range
 - 120-144 MHz, 15KW, PRF 500hz, PW 3 μ s, accuracy 1.5°
- Steerable and mobile
- **Over 1000 deployed**

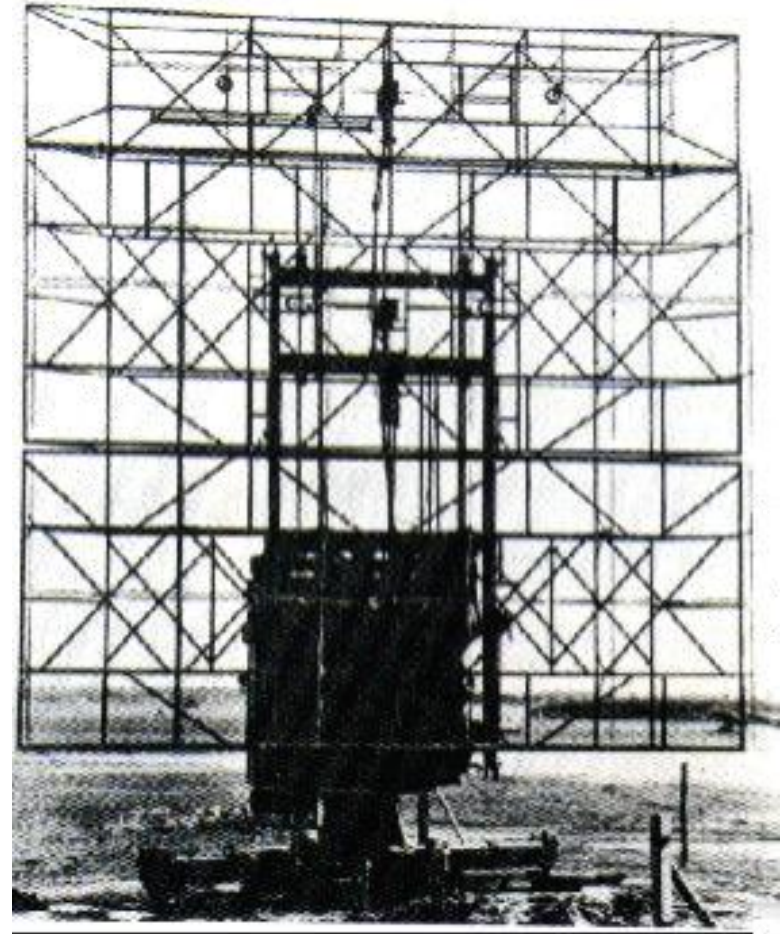

German Bi-Static Radar Klein Heidelberg

- Detect bombers by using the signals from the British Chain Home radars
 - Covert – no transmitter
 - Detection range 180-240 miles
- 6 KH Sites in France, Belgium and Netherlands
- Antenna 100' x 60'

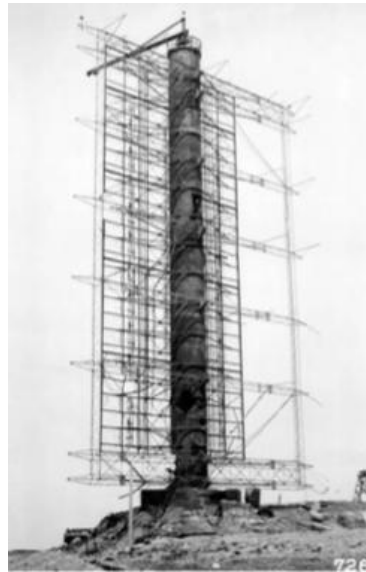

Bomber Command Loss Rate

PERCENTAGE LOSSES ON GERMAN TARGETS BY NIGHT, JAN. 1942 - APRIL 1945 ARE CALCULATED FOR EACH 3000 SORTIES. INTRODUCTION OF EACH R.C.M. DEVICE AND OTHER IMPORTANT FACTORS AFFECTING THE LOSS RATE ARE SHOWN AT THE APPROPRIATE DATES.

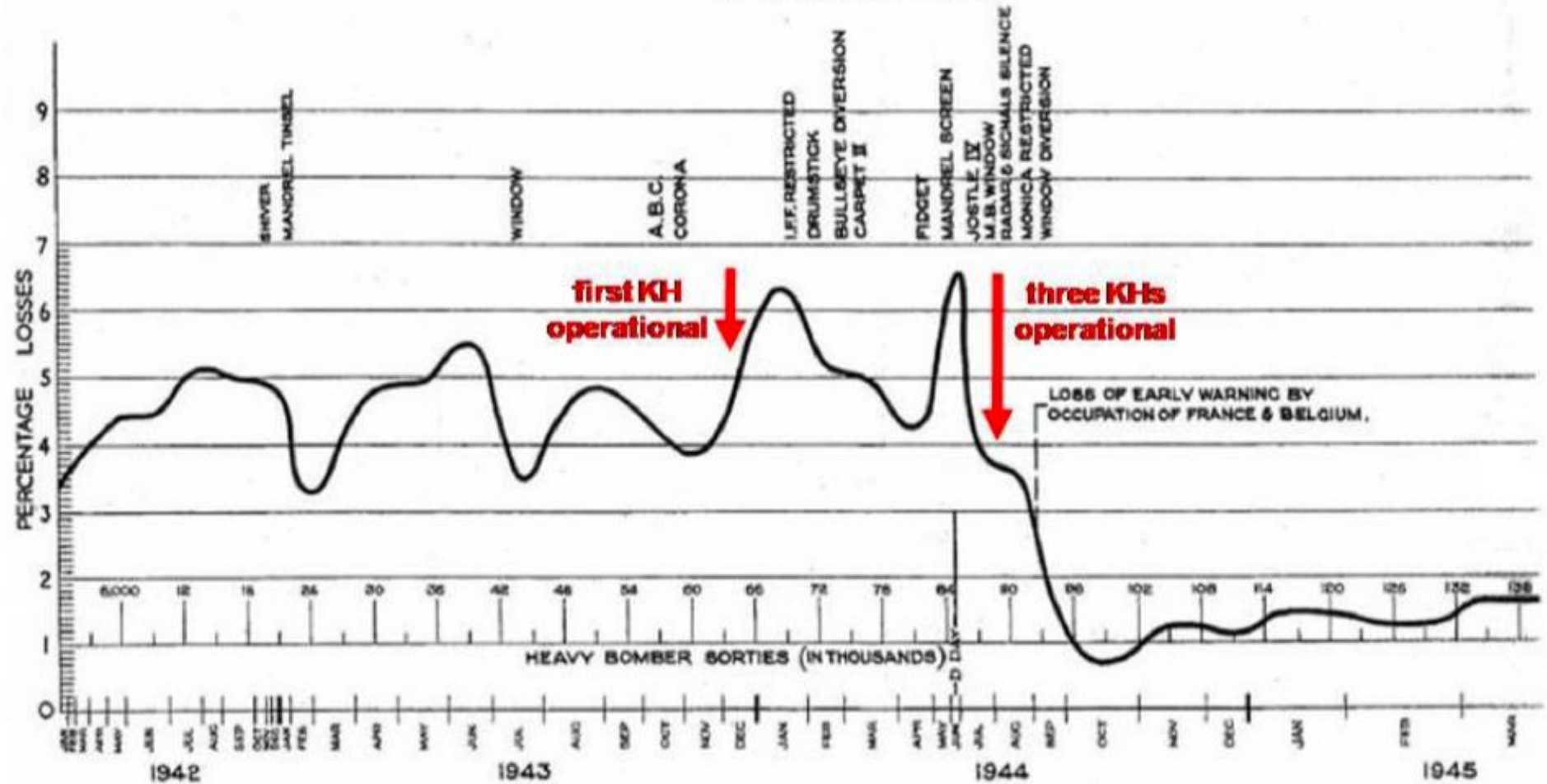

Luftwaffe Signals Intelligence Y-Service

- Network of *passive* intercept stations
- Picked up allied radio and bombing-radar signals
- Plotted location of bomber streams

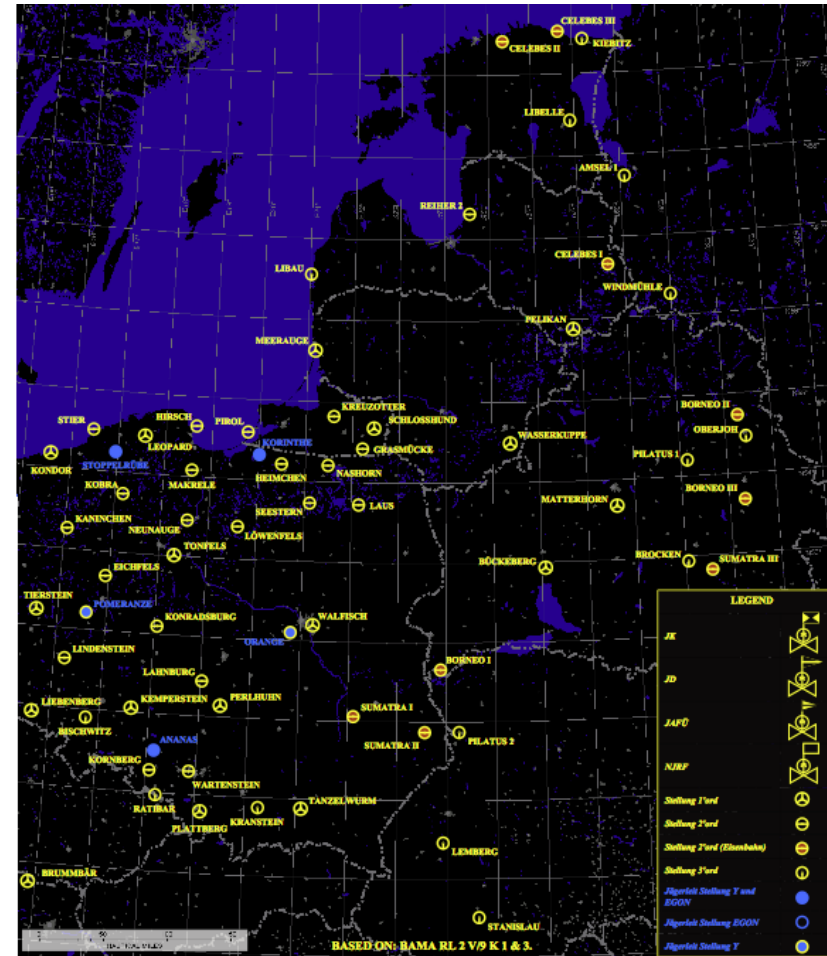

German Y-Service (ELINT)

- Passive signals intercept operation, known as the "Y-Dienst (Y-Service)"
- Used directional antennas and triangulation to locate Allied bomber formations from their radio/bombing radar/jammer emissions
- Y-Dienst impossible to jam, integral part of the air-defense system
- Directed night fighters into bomber streams, where they could use SN2 to hunt down targets

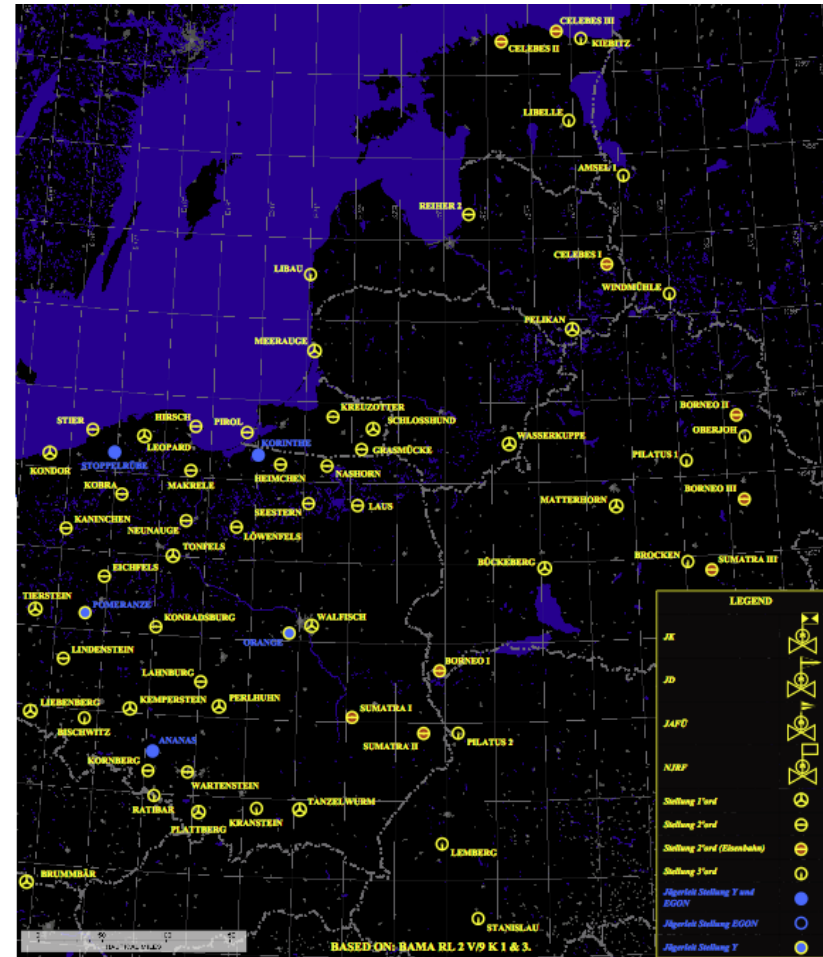



**By August 1941 only 10% of
British bombers got to
within 10 miles of their
target**

Getting to the Target

Solution: Electronic Navigation

- GEE
 - Used by Pathfinder Planes
 - Got you to the area
- OBOE
 - Used by Pathfinder Planes
 - Beacon Bombing System
 - Accurate enough for bombing
- GEE-H
 - Transponder System
 - Put on every bomber
 - Accurate enough for bombing

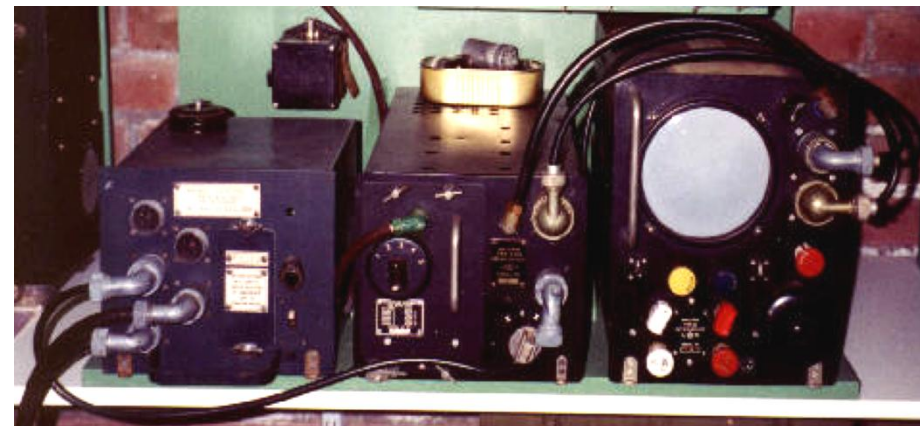
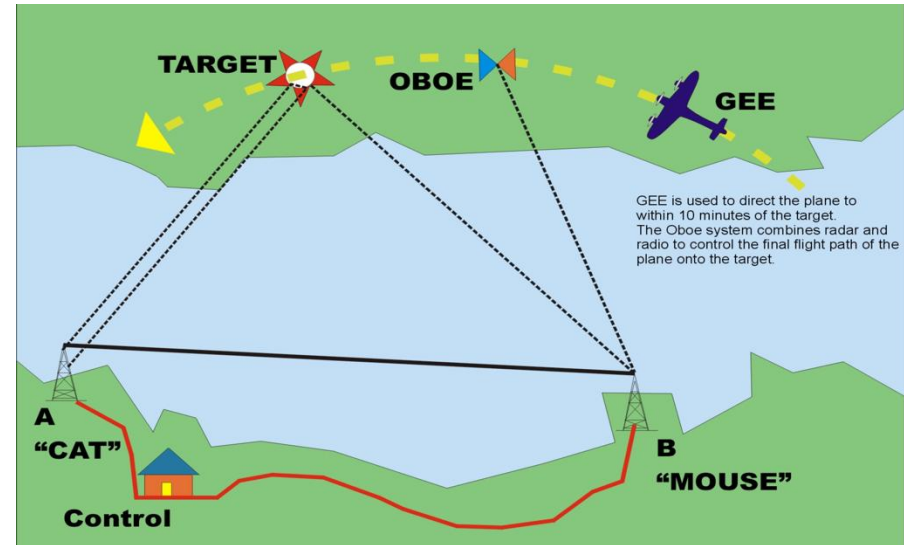



GEE - Electronic Navigation

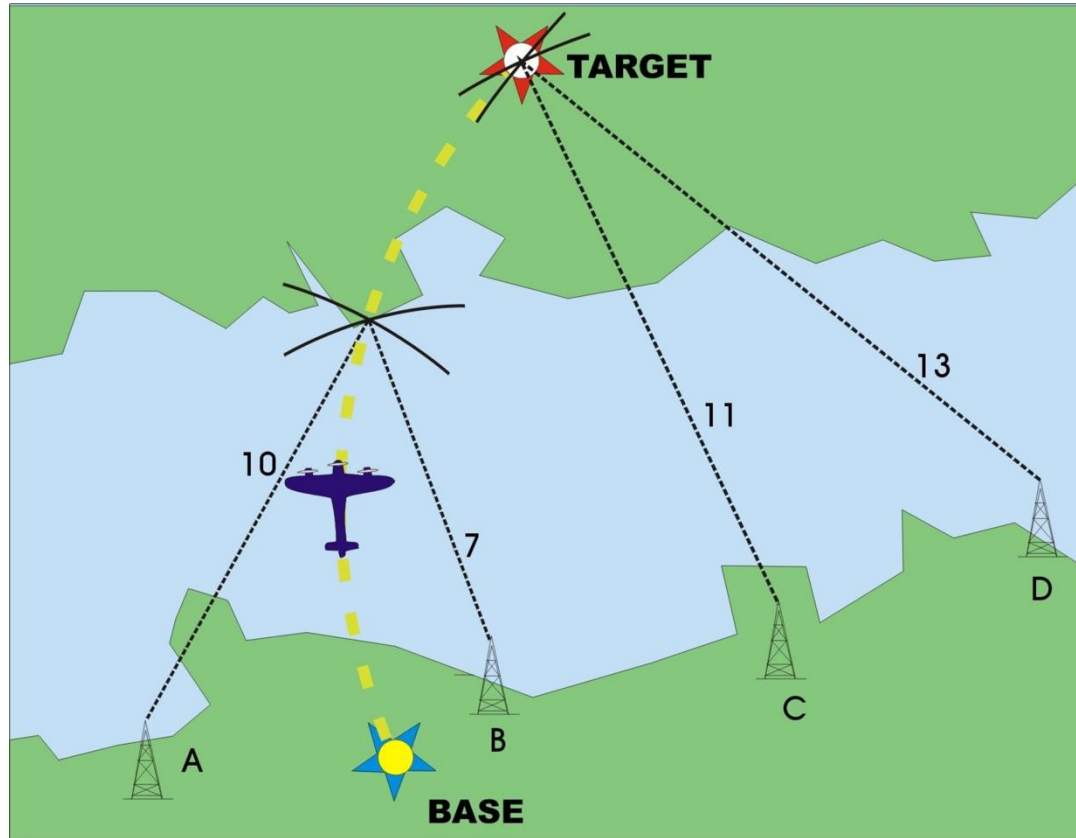

- 3 ground transmitters, including one "master" and two "slaves"
 - "A" and "B", were sited about 50 to 100 miles apart
- Time for signal to reach the aircraft can be measured and distance from that station can be calculated.



GEE - Electronic Navigation

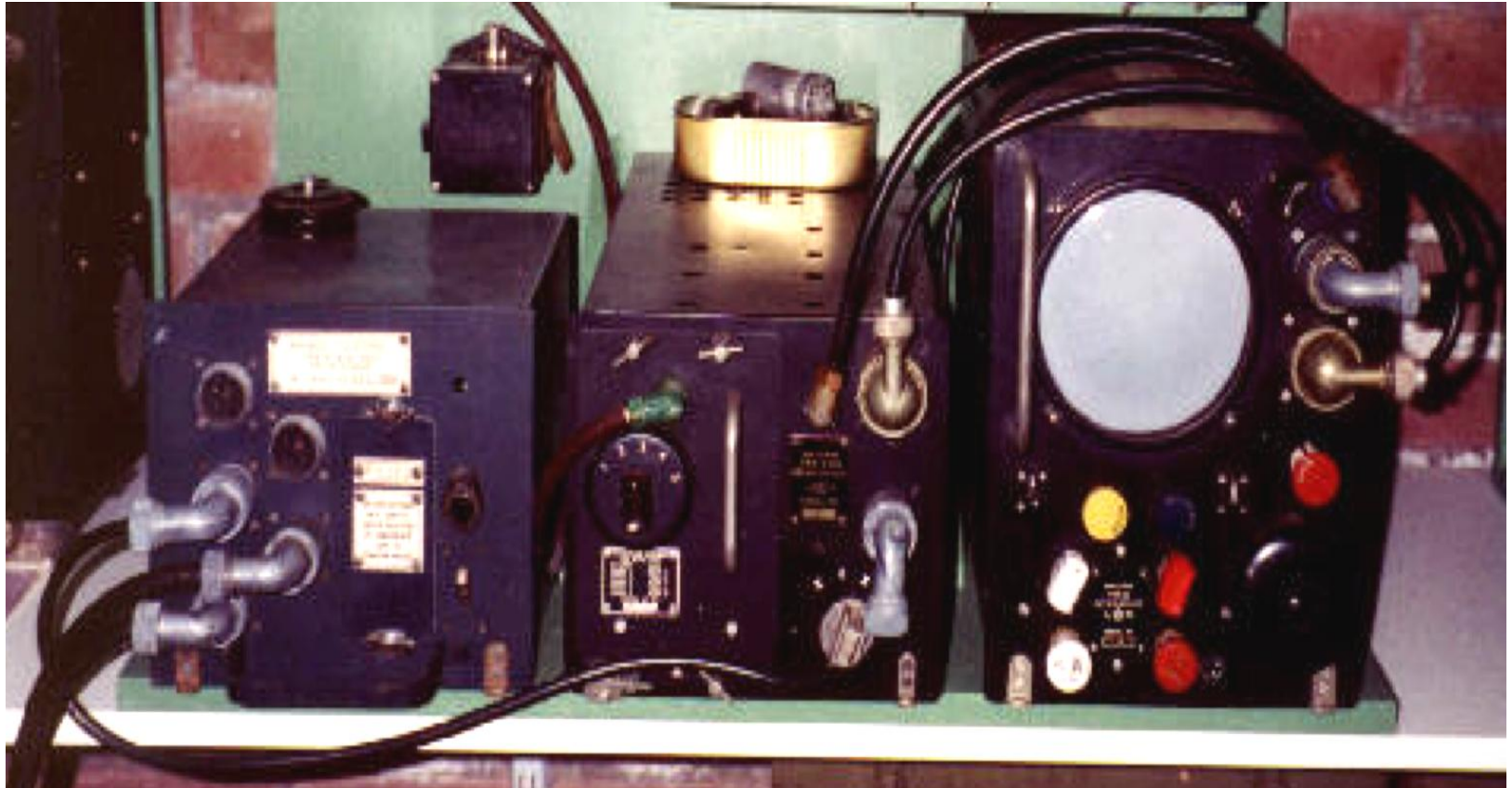

Gee on a B-17 Navigators station



GEE - Electronic Navigation

- Navigators need to measure comparative ratios from each pair of signals
- Aircraft had to follow a hyperbolic track to the target.

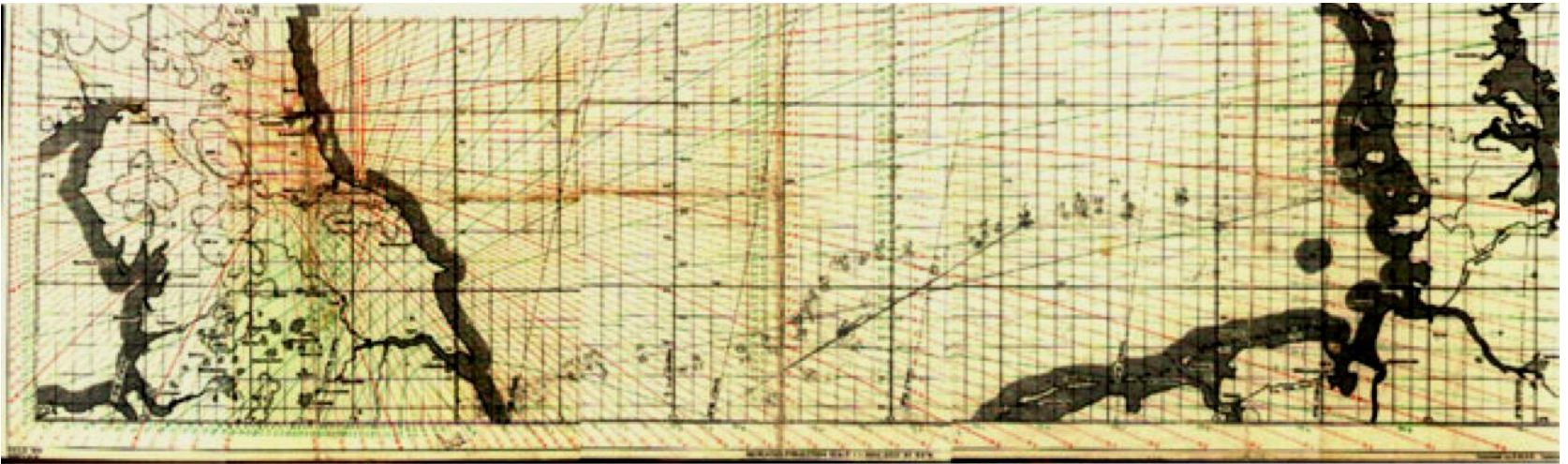

Gee Map - Edinburgh to Hamburg



Henrich - Jamming Gee

- German transmitters to jam Gee navigation signals
- **280** built





OBOE - Beacon Bombing System

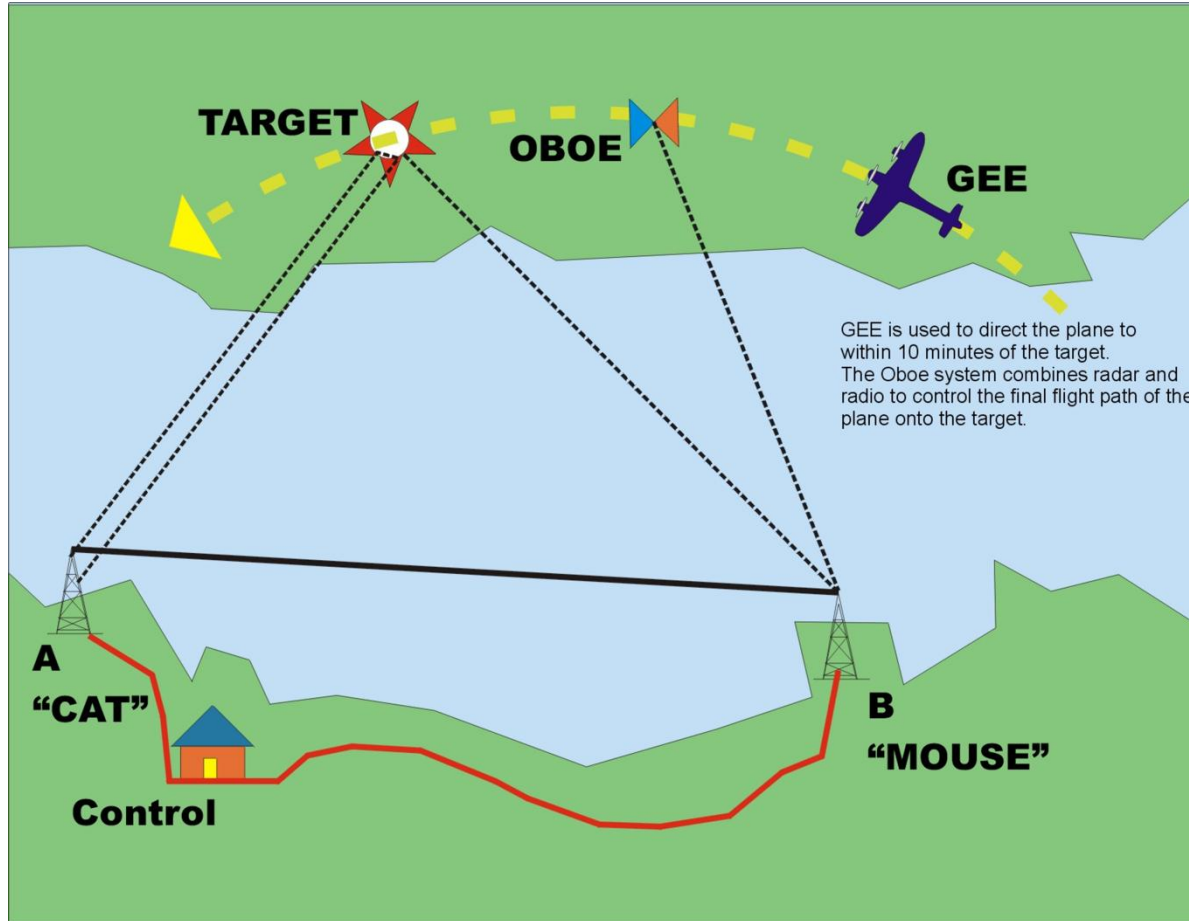

- GEE used to direct the plane to within 10 minutes of the target.
- The OBOE aircraft carried a transponder two ground stations, the cat and the mouse
 - Very precise; 50% of the bombs fell to within 45 yards of their target
 - only one plane could be controlled at a time - fitted to the Pathfinder planes
- Operational December 1942



GEE H - spring 1944

- GEE H worked like OBOE in reverse
 - The navigator of the aircraft became the operator, and the CAT and MOUSE stations were merely transponders.
 - The entire operation was conducted from the aircraft and directed by the navigator
- 150 foot accuracy @ 100 miles
- 300 foot accuracy @ 200 miles
- No limitations on number of aircraft using it

Flak - Radar Controlled Anti Aircraft Guns

- **15,000** Flak Guns
 - 400,000 soldiers in flak batteries
- Could reach to 30,000'
- Fused for time
- Radar-directed



105 mm flak

Flak: an abbreviation for Fliegerabwehrkanonen, german for anti-aircraft guns

Flak - Radar Controlled Anti Aircraft Guns

- **15,000 Flak Guns**
 - 400,000 soldiers in flak batteries
- Radar-directed flak to 30,000'
 - 128mm: 10 shells/minute
 - 105mm: 15 rounds/minute
 - 88mm: 15-20 rounds/minute
- Fused for time
 - Fragmentation rounds
 - No Proximity Fuses



105 mm flak

Flak: an abbreviation for Fliegerabwehrkanonen, german for anti-aircraft guns



Flak - Radar Controlled Anti Aircraft Guns

- 1,000,000 soldiers in flak batteries
- Radar-directed heavy flak
 - 128mm: 10 shells/minute to 35,000"
 - 105mm: 15 rounds/minute to a maximum altitude of 31,000
 - 88mm: 15-20 rounds/minute to a maximum altitude of 35,000
- Fused for time
 - Fragmentation rounds
 - Germans did not have Proximity Fuses



.....105mm flak.....

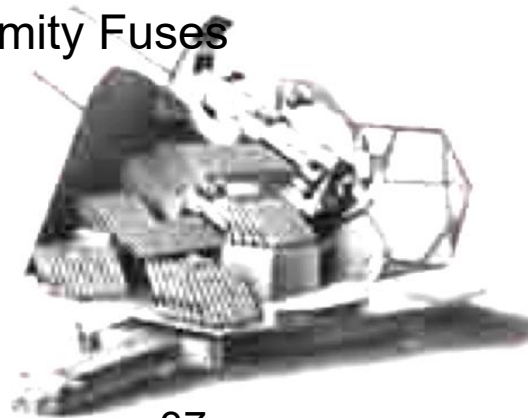

.....37mm.....



.....20mm.....

Wurzburg Anti-Aircraft Radar

- Radar control of flak guns
- 15 mile range
- 10 feet wide
- Steerable and Mobile
- **~ 5,000** deployed



Wurzburg Anti-Aircraft Radar

- Fire control of flak batteries
- 15 mile range
 - 533-566 MHz frequency agile
 - 10KW, PRF 3750hz, PW 2us, Accuracy 25 meters
- 10 feet wide
- Steerable and Mobile
- ~ **5,000** deployed



Himmelbelt

Radar Order of Battle

- Freya
 - early warning radar
 - detect allied bombers
- Giant Wurzburg
 - Ground Controlled Intercept radar
 - direct fighters to bombers
 - fighters could then intercept with their on-board radar

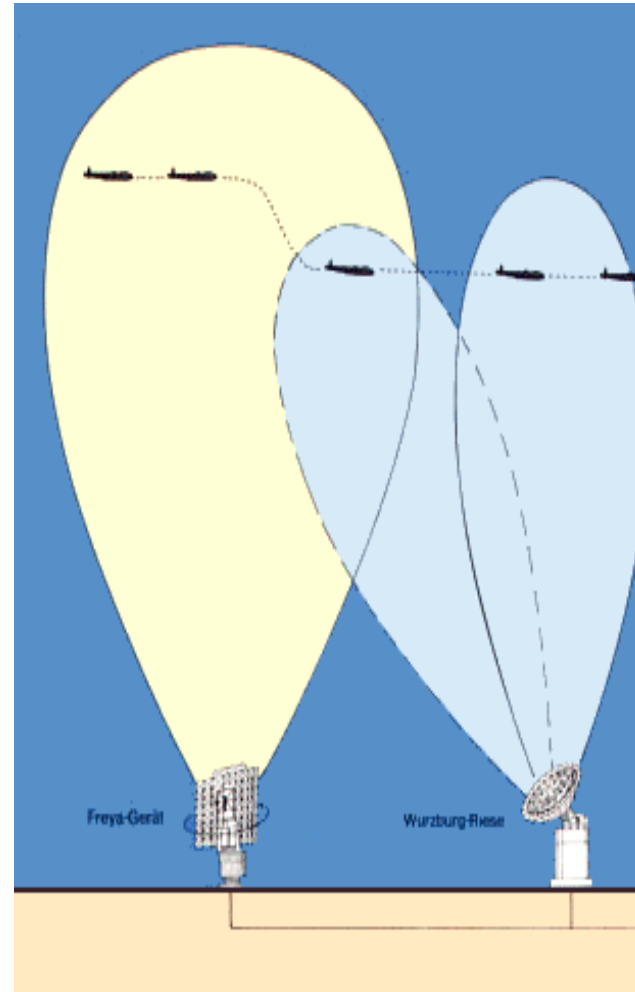

Operation Biting - Raid on Bruneval

- Commando raid to *steal* a Würzburg
- 27 February 1942
- Captured all the radar electronics and technicians
- Used it to test countermeasures

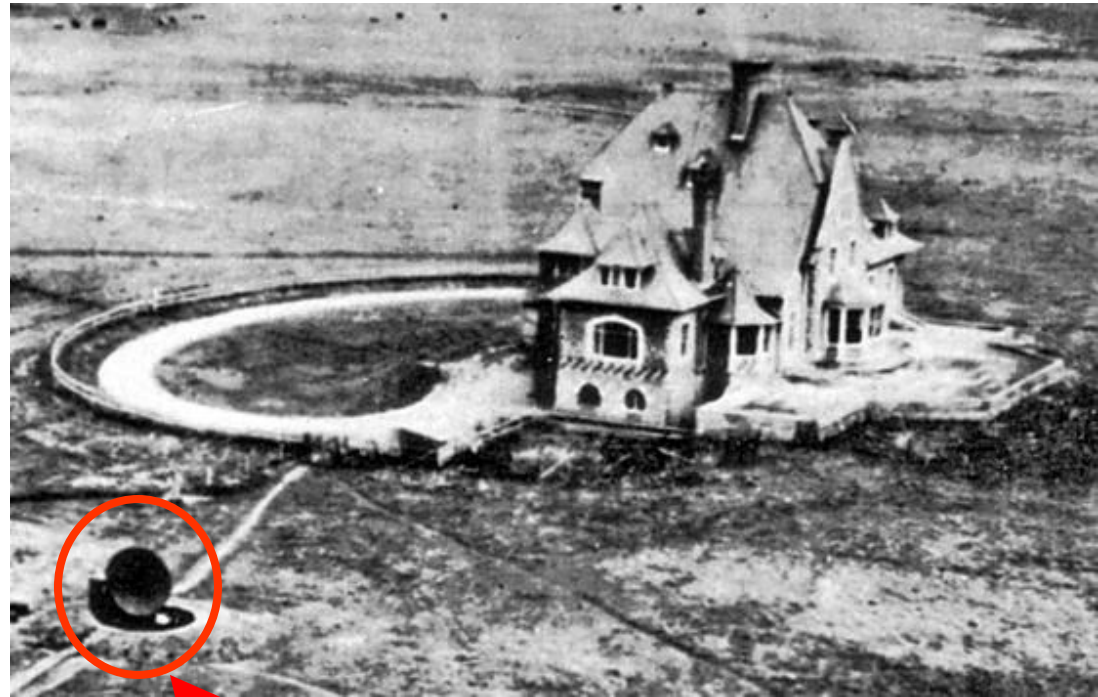

What's this?

Operation Biting - Raid on Bruneval

- Commando raid to *steal* a Würzburg
- 27 February 1942
- Captured all the radar electronics
- Used it to test countermeasures

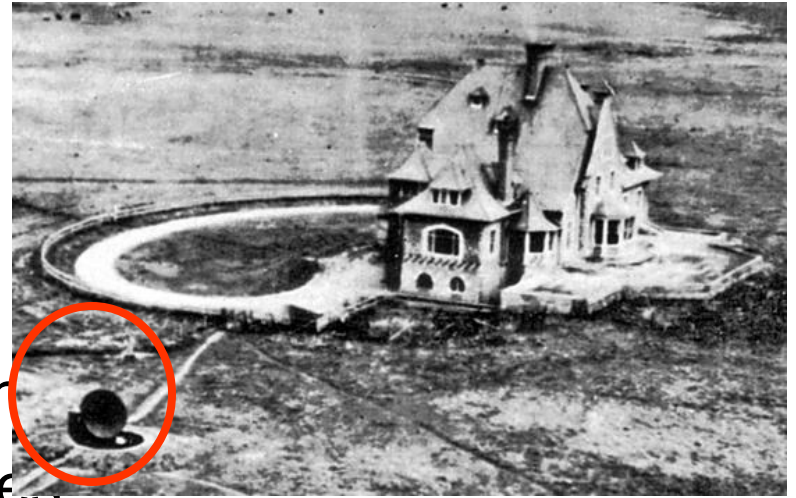

Giant Wurzburg Ground Control Intercept Radar

- 45 mile range
- Used to guide German fighters to the bombers
- 25' wide
- over **1,500** deployed

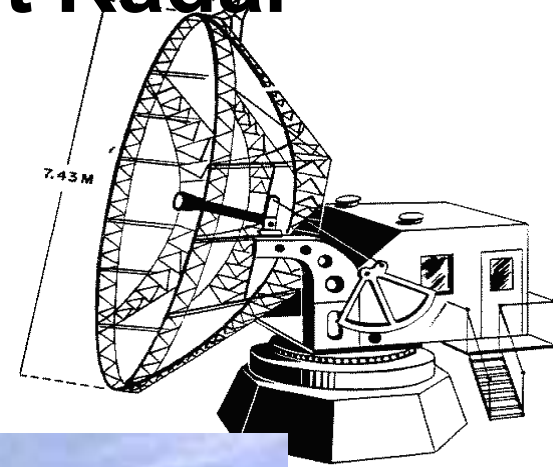

Giant Wurzburg Ground Control Intercept Radar

- 45 mile range
 - 533-566mhz frequency
agile, 10KW, PRF 1875hz,
PW 2 μ s
- GCI radar
- 25' wide
- **over 1,500 deployed**

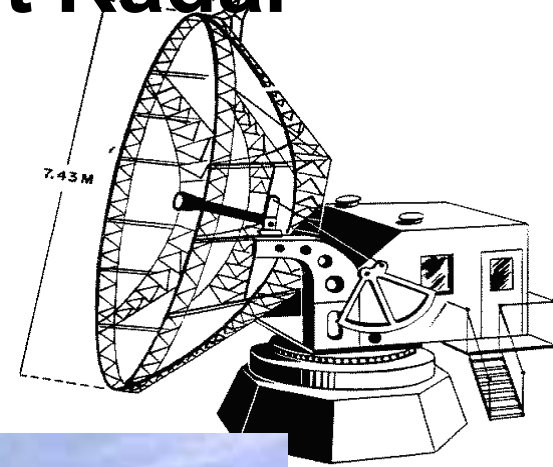

Himmelbett

Air Battle Air Traffic Control

- Radars fed Himmelbett centers
- Operators worked from rows of seats in front of a huge screen
- Fighters would fly orbits around a radio beacon
 - fighter controller talked it to the vicinity of the target
- Fighters would turn on its radar, acquire the target, and attack



Himmelbelt

Radar Order of Battle

- Freya
 - early warning radar
 - detect allied bombers
- Giant Wurzburg
 - Ground Controlled Intercept radar
 - direct fighters to bombers
 - fighters could then intercept with their on-board radar
- Lichtenstein BC & SN2
 - Airborne radar on German nightfighters

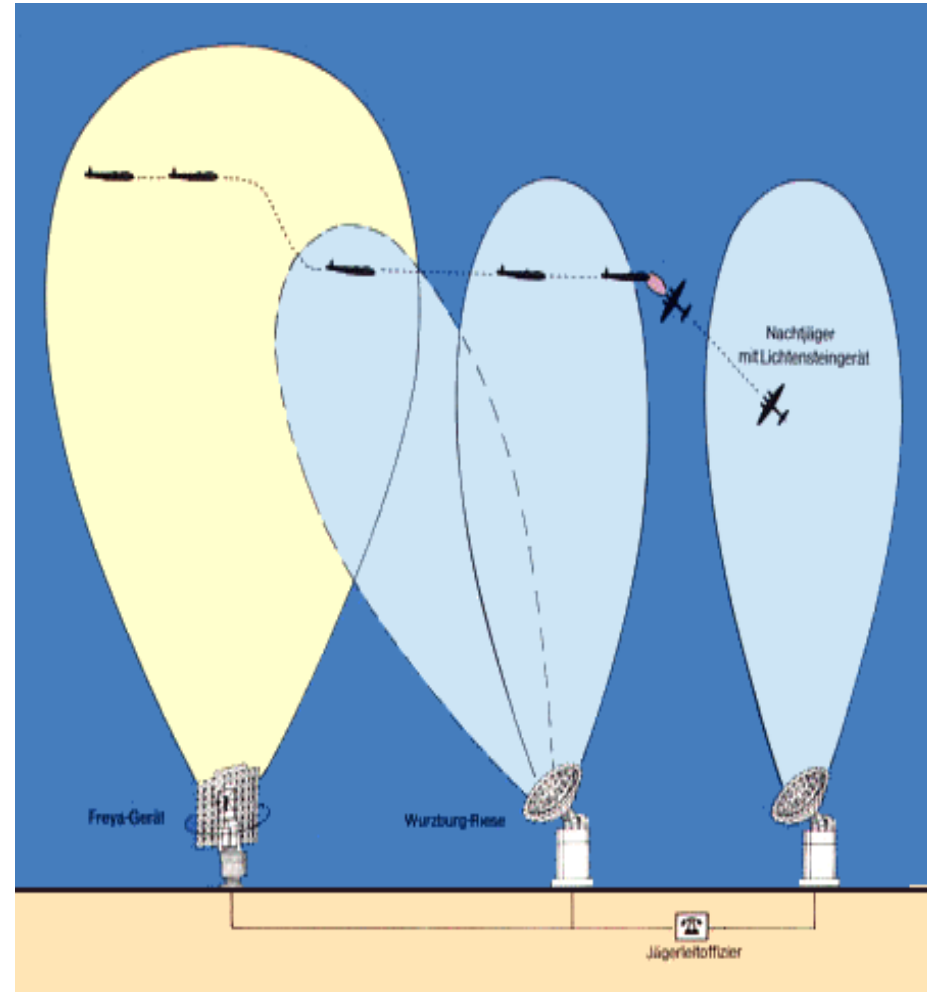

German Night-Fighters

Airborne Intercept Radar



What's this?

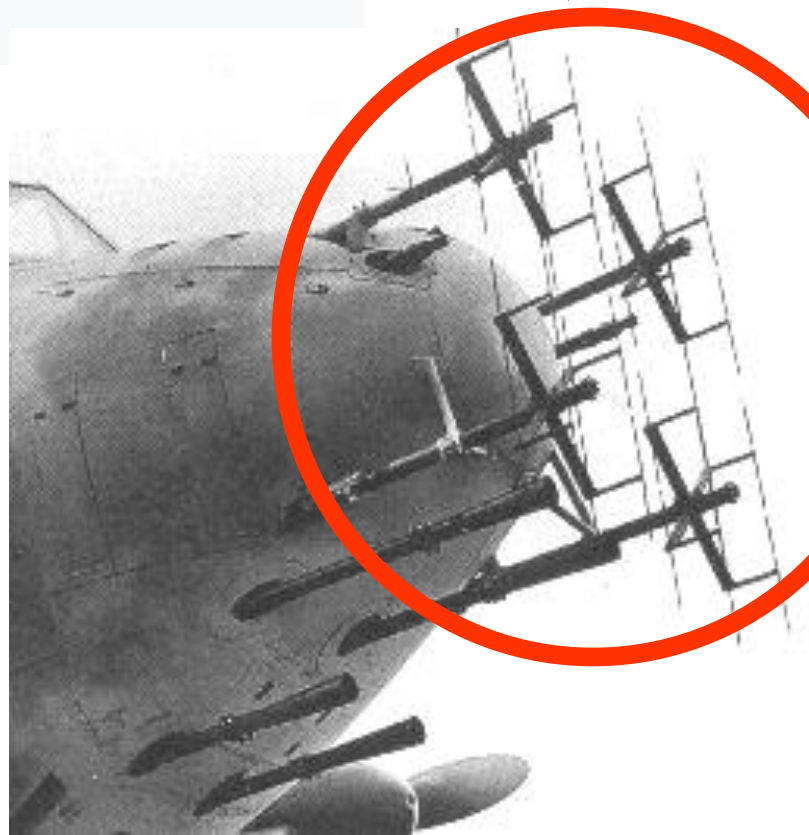

- Directed to vicinity by ground radar
- Allowed the German fighters to find the bombers at night



German Night-Fighters On-board Radar



- Directed to vicinity by ground radar
- Dornier Do 17, Junkers Ju 88, Messerschmitt Bf 110
- “Lichtenstein” B/C then SN2 Radar
 - Range 2.5 miles, 400mhz then 90mhz

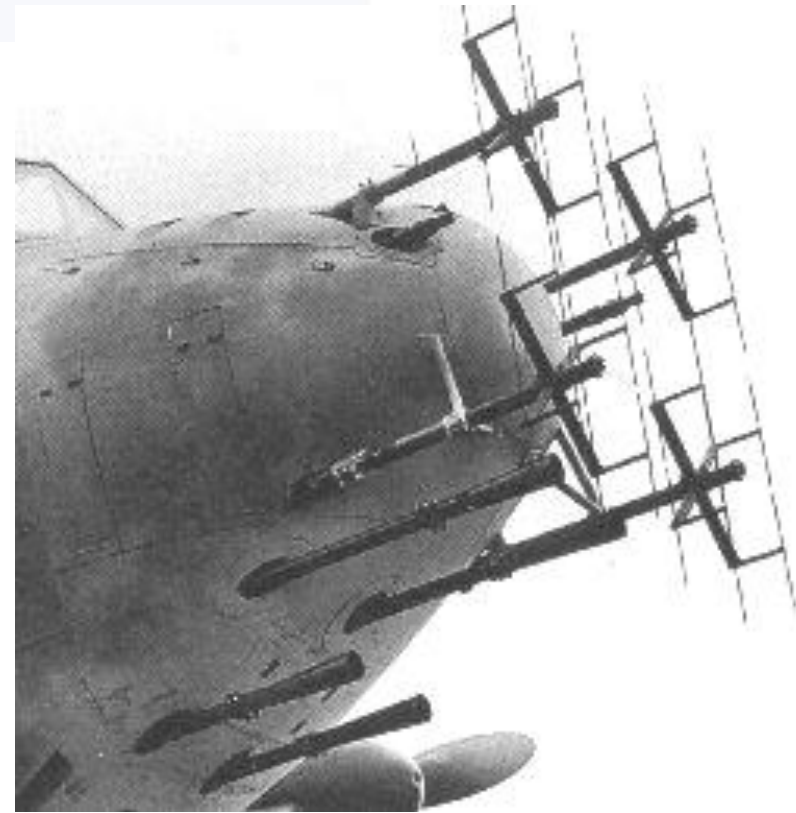



Monica - Tail Warning

- Warned bombers that fighter radar was looking at them
- Deployed June 1943
- Prone to false alarms due to other bombers in the stream that it was of little use



Flensburg - Fighter Homing on Monica

- Passive homing device
- On German Fighters
- Detect the emissions of Monica tail-warning radars of the RAF bombers.
- 45 miles range
- Production Spring of 1944



Korfu - Bomber Early Warning

- A network of "Korfu" aircraft warning systems to warn against Allied bomber squadrons
- It picked up the emissions of the British bomber "H2S" radar sets.
- This was one of the German's most reliable early warning systems
 - could detect bombers taking off from their bases





German Day Fighters Vectored by Ground Radar

- Ground Control Intercept radar talked the fighters into visual range of the bombers
- Messerschmitt BF-109, Focke Wolf 190





End of Himmelbett - Start of “Tame Boar/Wild Boar”

- “Window” meant German fighters couldn’t be vectored to the bombers
- Germans reorganized fighter control
- Fighters were scrambled and directed from radio beacon to radio beacon until they arrived to the greatest concentration of Window
- At the target the fighters located the bombers with their airborne Lichtenstein radar, or visually using the light of the fireglow or flares
- “Wild Boar” tactics operated fighters over the targets themselves



Tame Boar/Wild Boar Bases

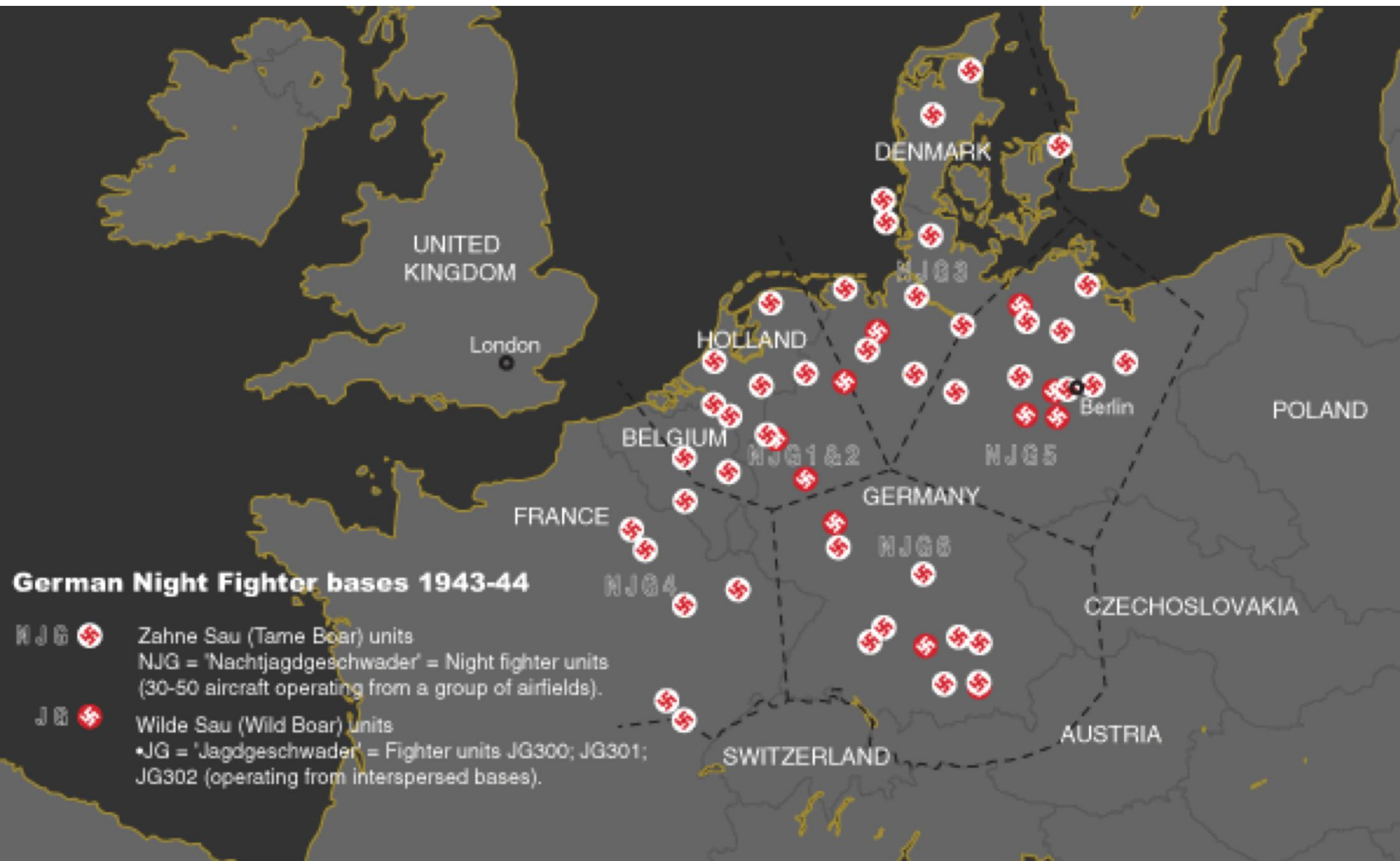



**Not many clear days a month in
winter over Europe**

How did they see the target?

Bombing Through Overcast

Solution: Air to Ground Bombing Radar

- Radar aimed at the ground
 - Targets could be seen under clouds and rain
 - Outlines of major ground features
 - map overlays
- 1943



Bombing Through Overcast

Solution: Air to Ground Bombing Radar

- Radar aimed at the ground
 - Targets could be seen under clouds and rain
 - Outlines of major ground features
 - map overlays
- British in Mid 1943
 - H2S 300mhz
- Americans in late 1943
 - H2X / APS-15 3ghz
 - B-24 & P-38 Pathfinders
- Oops - Naxos





H2S – Bombing Radar

- A downward-facing rotating spiral scanner
 - mounted in a blister below the bomber
- Image of towns 50 miles away displayed on the screen.
- Target identified by major landscape features, such as river bends and confluences

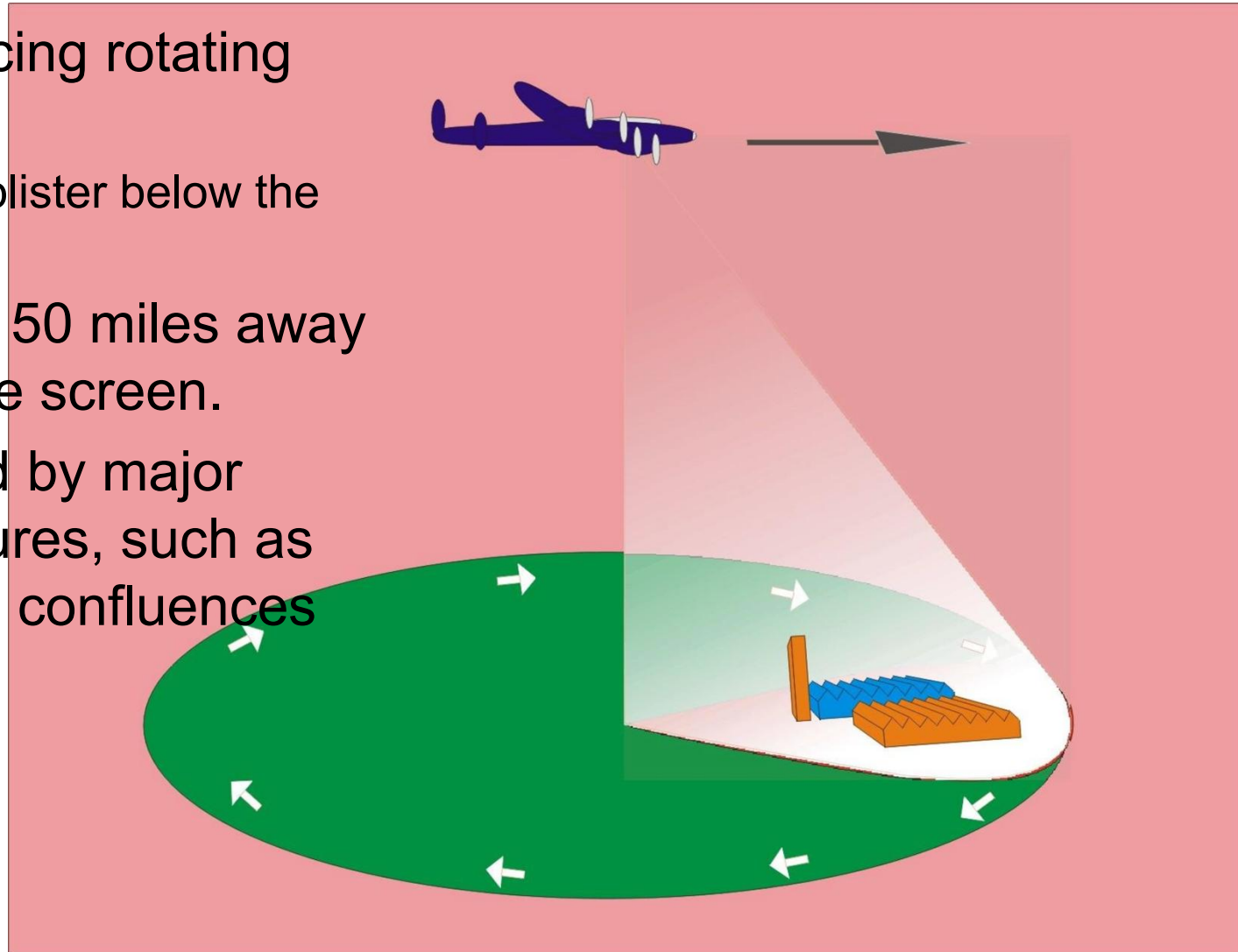



H2S and GEE Bomber Electronics

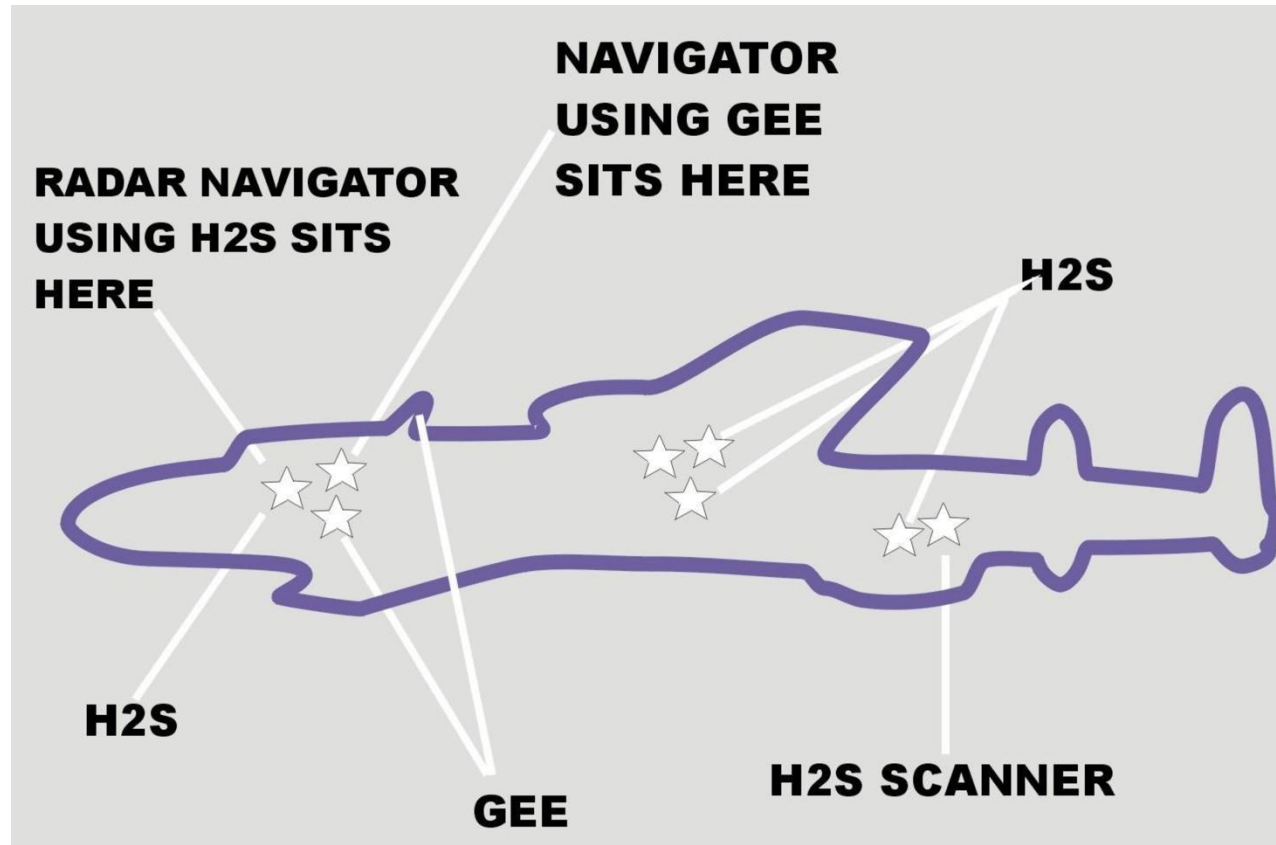

- **January 30th 1943:** The first use of H2S ("Home Sweet Home") fitted to a 'Pathfinder' Squadron over Hamburg
- Weather was poor but the results were successful.
- Now bombers could be flown to their targets using GEE and drop their bombs using H2S



Naxos - Homing in on Bombing Radar

- German night fighters were equipped with the "NaxosZ"
- Homed in on the H2S radar in Allied bombers
- Range 30 miles





H2X - American Bombing Radar

- **Nov 1943**, 12 B-17 Pathfinders get H2X
- **By Nov 1944**, all Pathfinders equipped with H2X
 - including Lockheed P-38 fighters with long "Mickey" noses.
- "Offset bombing" was devised, in which a target that didn't have a good radar signature was located relative to nearby landmarks that did

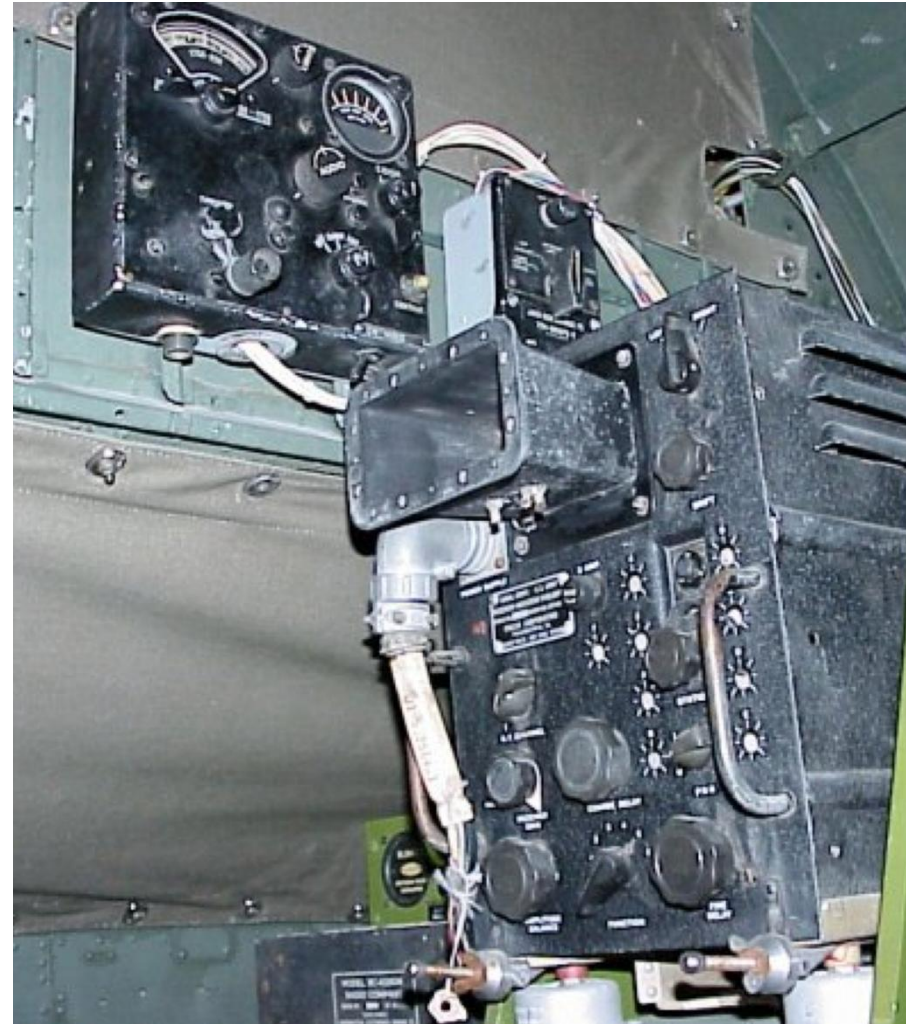



B-17 Bombing Radar - H2X

- Installed on all bombers
- The H2X Radar made bombing through overcast (BTO) possible. The radar dish replaced the ball turret of the Pathfinder planes
- The "Mickey set" was installed in the radio room and navigational and bombing information was given to the Navigator and bombardier

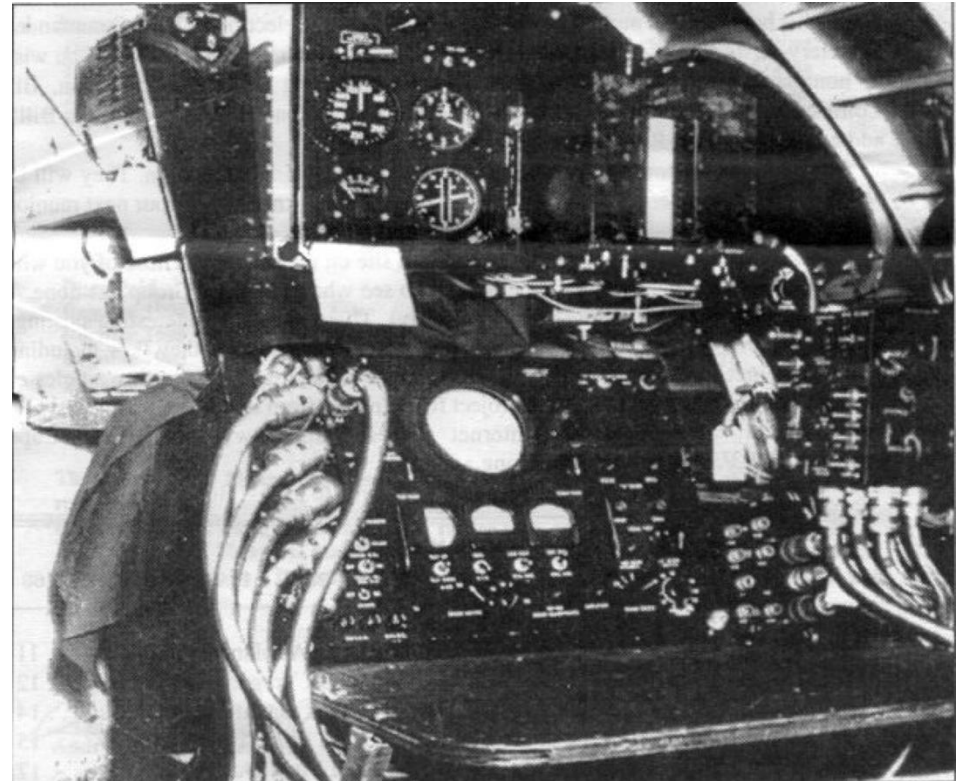

Math Challenge

For every 100 bombers on a mission

4 - 20% would not return

Crews had to fly 25 mission to go home

Story 2: The Electronic Shield - Electronic Warfare

Harvard Radio Research Lab (RRL) Signals Intelligence and Electronic Warfare

- Reduce losses to fighters and flak
- Find/understand German Air Defense
 - Electronic and Signals Intelligence
- Jam/confuse German Air Defense
 - Radar Order of Battle
 - Chaff
 - Jammers
- Top Secret 800 person lab



SIGINT – **S**ignals **I**ntelligence

The Line of Sight Problem

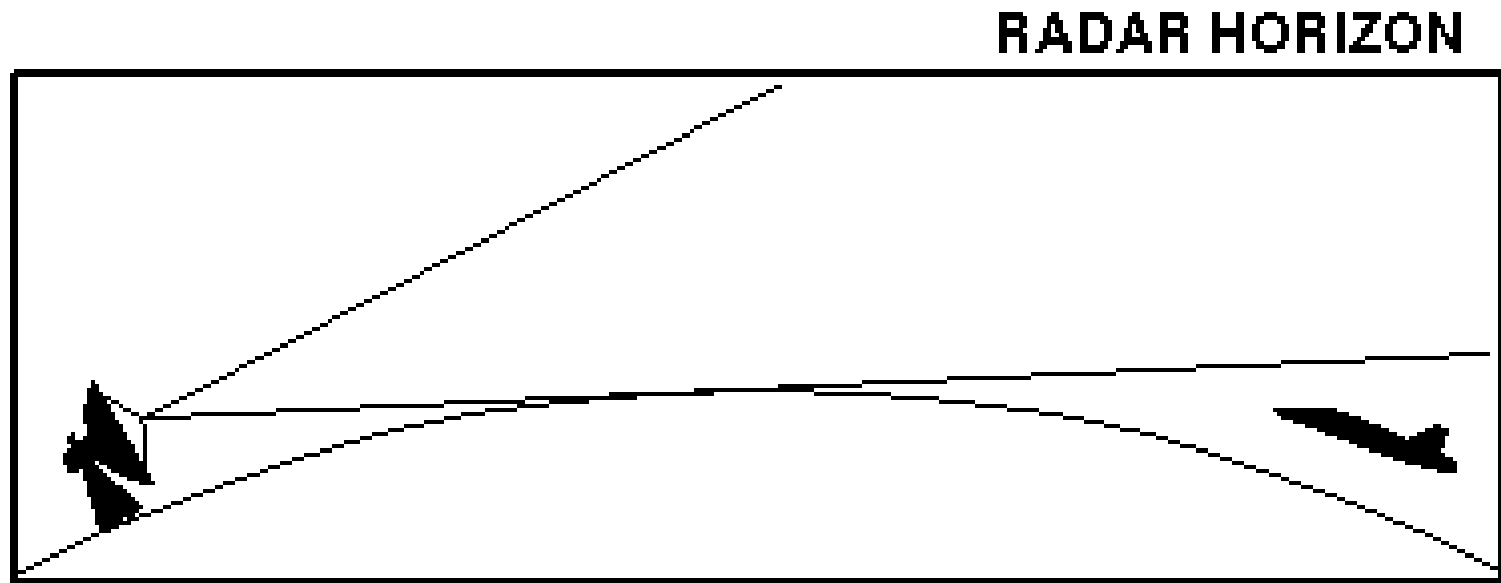

You got to get close!

SIGINT using Ferret's

Find and understand German Air Defense

- Ferret's and Crows
- B-24J flights inside Germany to intercept German radar signals
- Fitted with receivers & displays
- Wire and strip recorders
 - Frequency, pulse rate, power, etc.
 - 50 MHz to 3 GHz



SIGINT using Ferret's Find and understand German and Japanese Air Defense

- Ferret I went to the Aleutians
- Ferrets III, IV, V went to Sicily and the Mediterranean
- Ferrets VII, VIII went to South Pacific
- British Ferrets found the German Radars on the French invasion coast



8th Airforce Signals Intelligence

- Used British Y-Service intercepts of Luftwaffe Communications
 - Bomber route planning to miss fighter bases, assembly and timing
 - Measure effectiveness of diversions
 - Measure effectiveness of escort fighters
 - Near real-time bombing results
 - Also intercepts of AAA communications

SIGINT Map of Japanese Radar Order of Battle

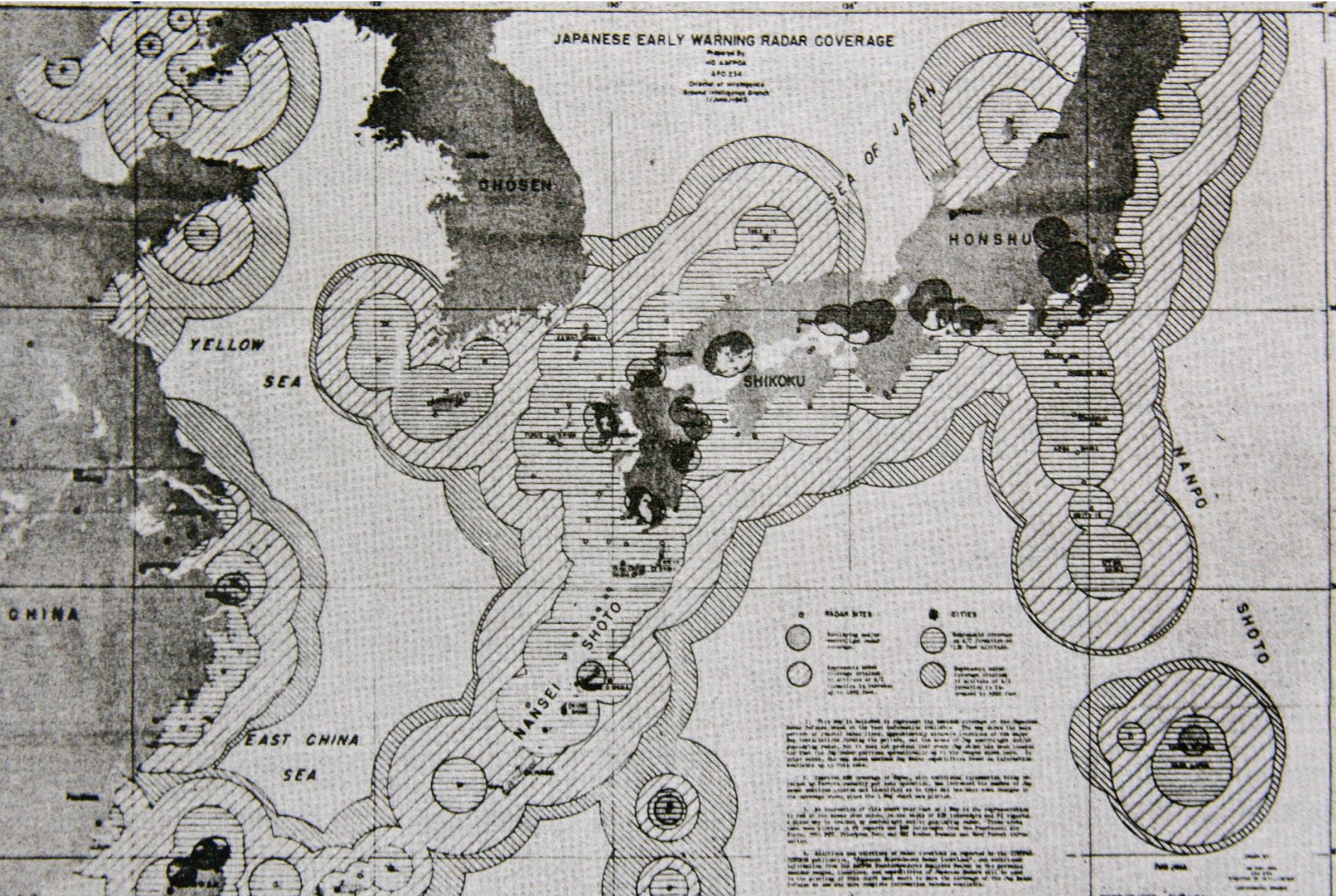

Window/Chaff

Jam Wurzburg AAA & GCI Radar

- Strips of aluminum foil
 - 1/2 Wurzburg frequency
- 46,000 packets tossed out by hand
 - Each packet contained 2,000 strips
 - Automatic dispensers came later
- First used July 1943
 - Raid on Hamburg
 - Shut down German air defense
- Used 3/4' s of Aluminum Foil in the US
 - 200 tons a week of chaff



Drop Chaff to Jam Radar



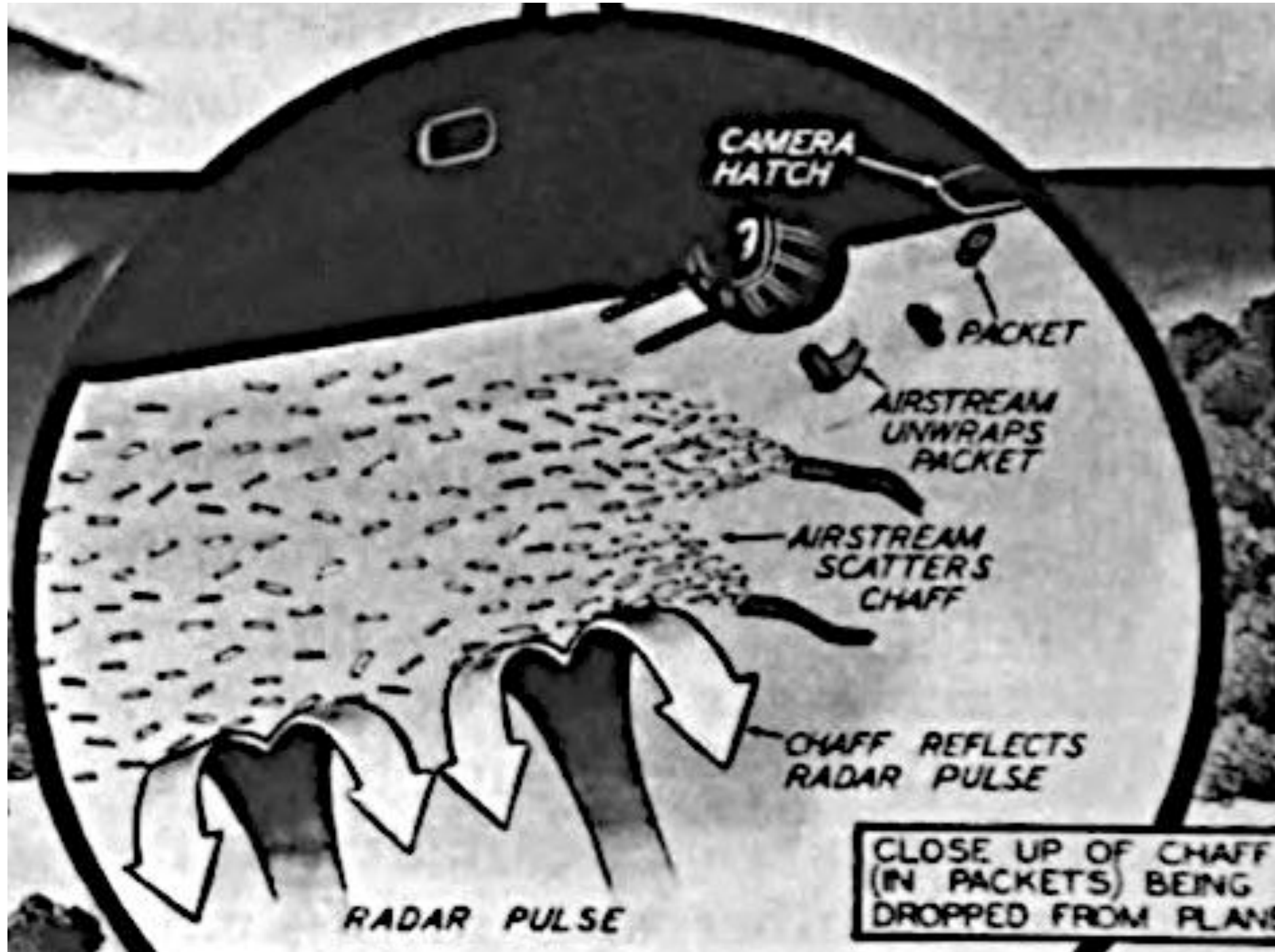

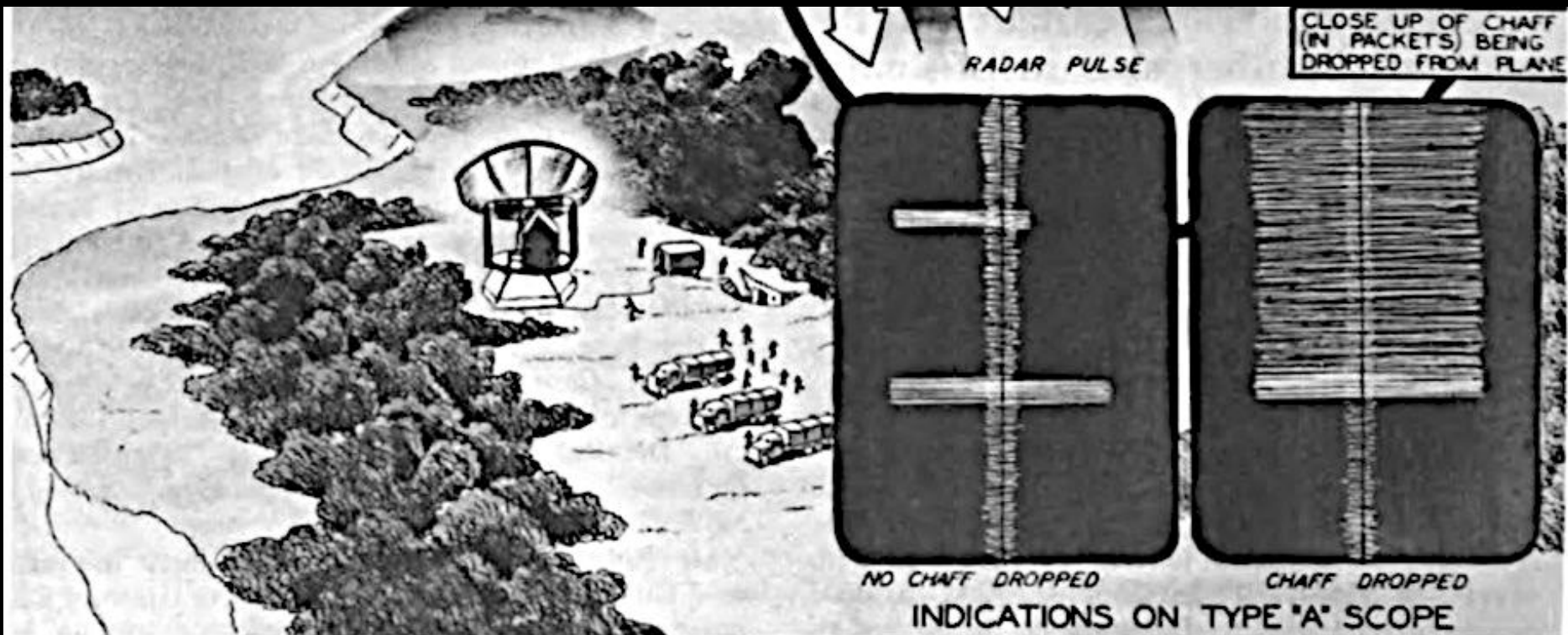

Shut down Flak and GCI

Jam Wurzburg's

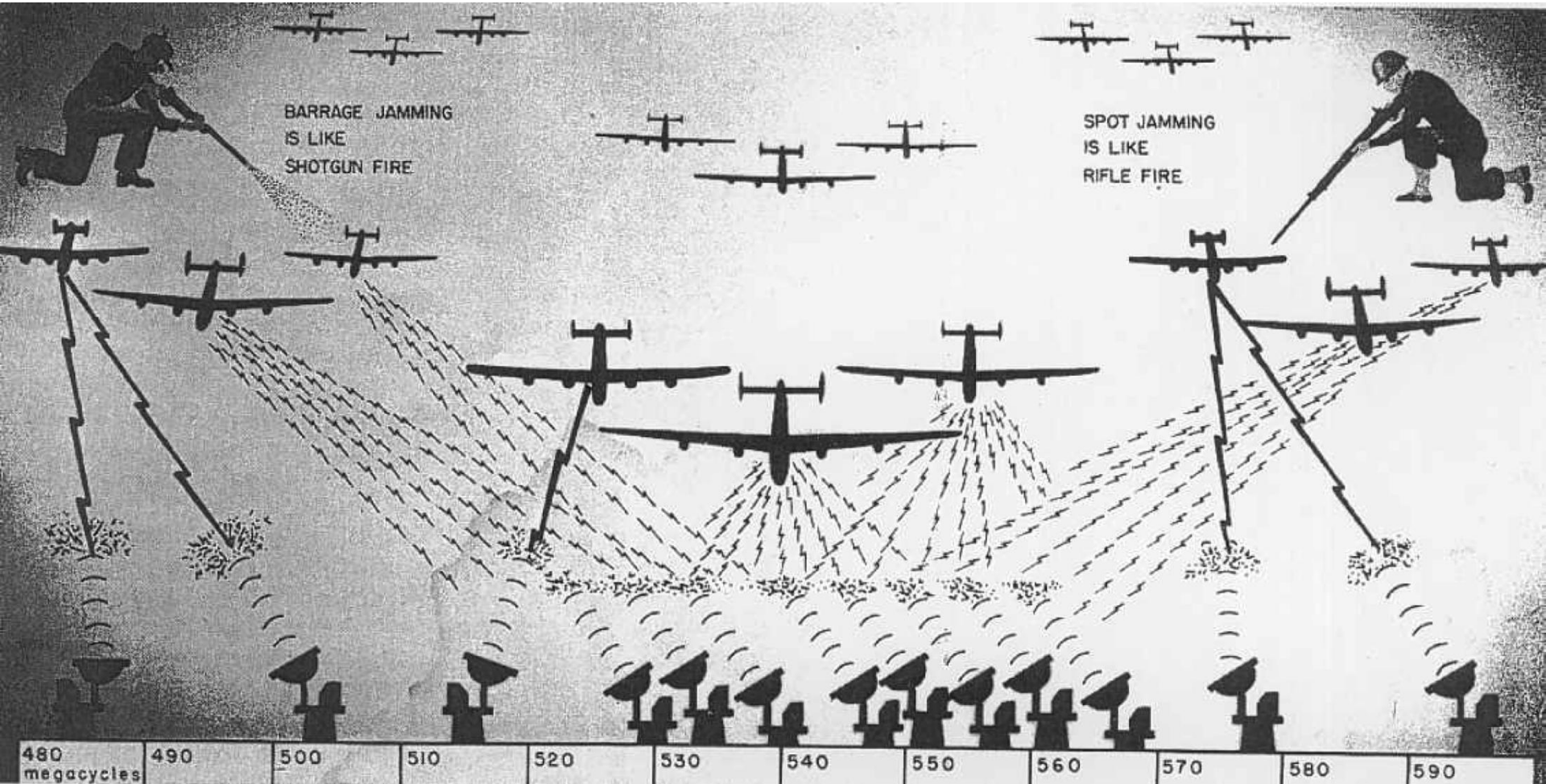

Electronically Blind German Radar Jam the Radars with Noise

- Put Jammers on Airplanes
- Jam and shut down
 - Early Warning Radars
 - Anti-aircraft Radars
 - Fighter Radars
 - Ground Control Radars
- Built over **30,000** jammers



MANDREL
Jammer



DINA
Jammer

DINA German Early Warning Radar

Jam Wassermann, Mammoth and Freya

- Put Jammers on Airplanes
- Mandrel/APT-3
- DINA/APT-1
 - First on escort fighters
 - Later on bombers
 - 12 watts



MANDREL
Jammer



DINA
Jammer

Shut down Flak & Ground Control Radar Jam the Wurzburg's

- “Carpet” AN/APT-2 Jammer
 - Confuse Wurzburg radar
 - Shut down flak
 - Shut down GCI
 - 5 Watts
- **24,000 built**
 - On all bombers



Carpet Jammer

Shut down and Spoof Fighter Ground Control

Jam Fighter/Ground VHF Radio Links

- "Tinsel"
 - Microphones in the engine nacelles of a bomber broadcast noise
- "Corona"
 - German-speaking RAF personnel, broadcast fake controller instructions
- "Airborne Cigar"
 - Jammed VHF Nightfighter Ground Control Intercept comm
 - Flew in special ops Lancasters
- "Jostle IV"
 - Jammed VHF Ground Control Intercept comm
 - Took up the entire bomb bay of a B-17



British Jam German Night Fighter Radar

- Airborne Grocer
 - Jam Lichtenstein Night Fighter radar
- On all British bombers
- Monica
 - Tail warning system
 - Oops, German Flensburg

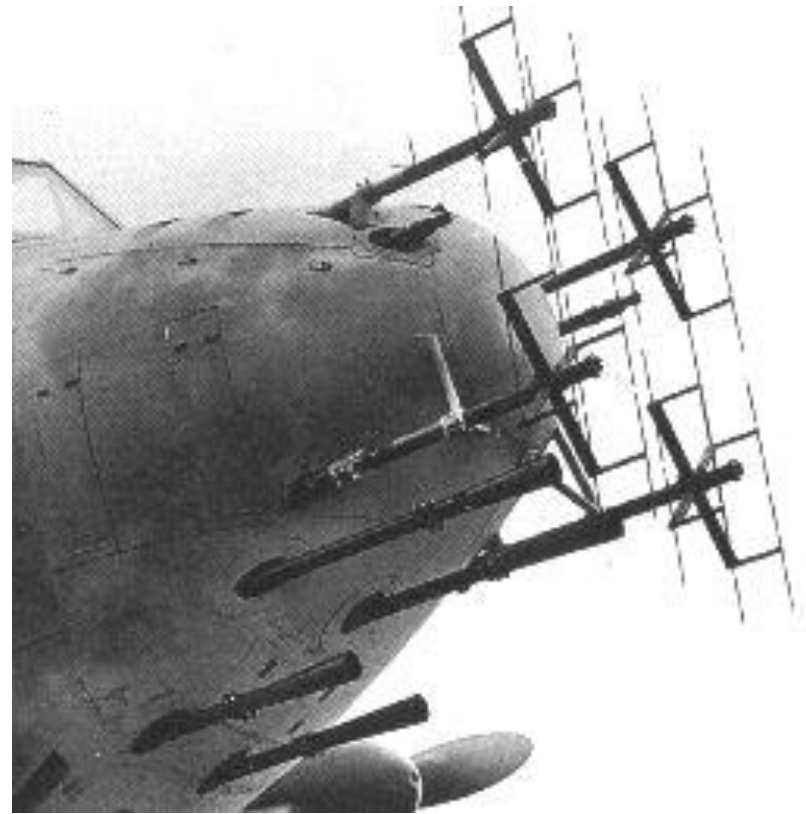

Jammer Versus Radar Coverage

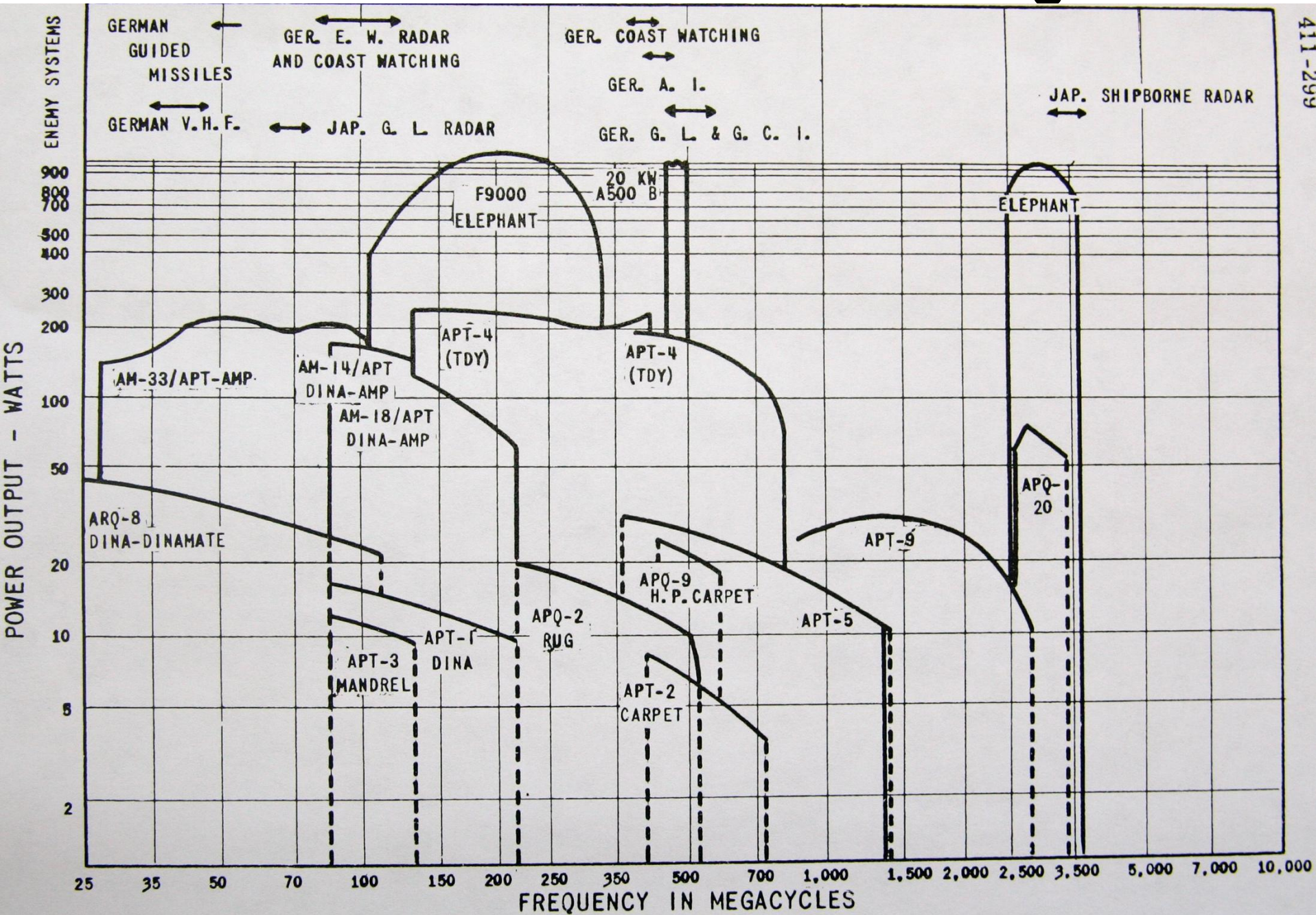

German Radars on the Coast of France

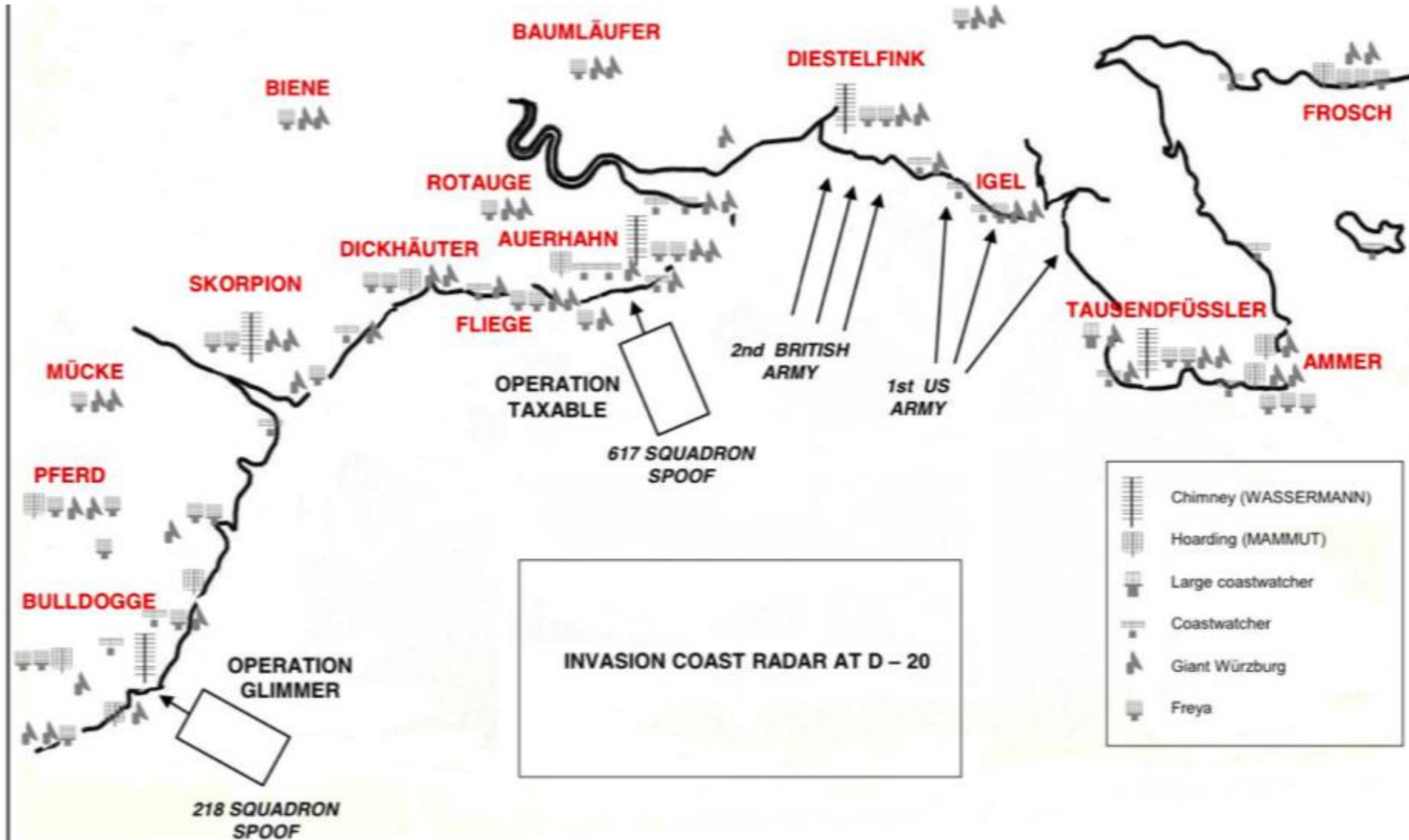

Radar Jamming for D-Day Operation Overlord

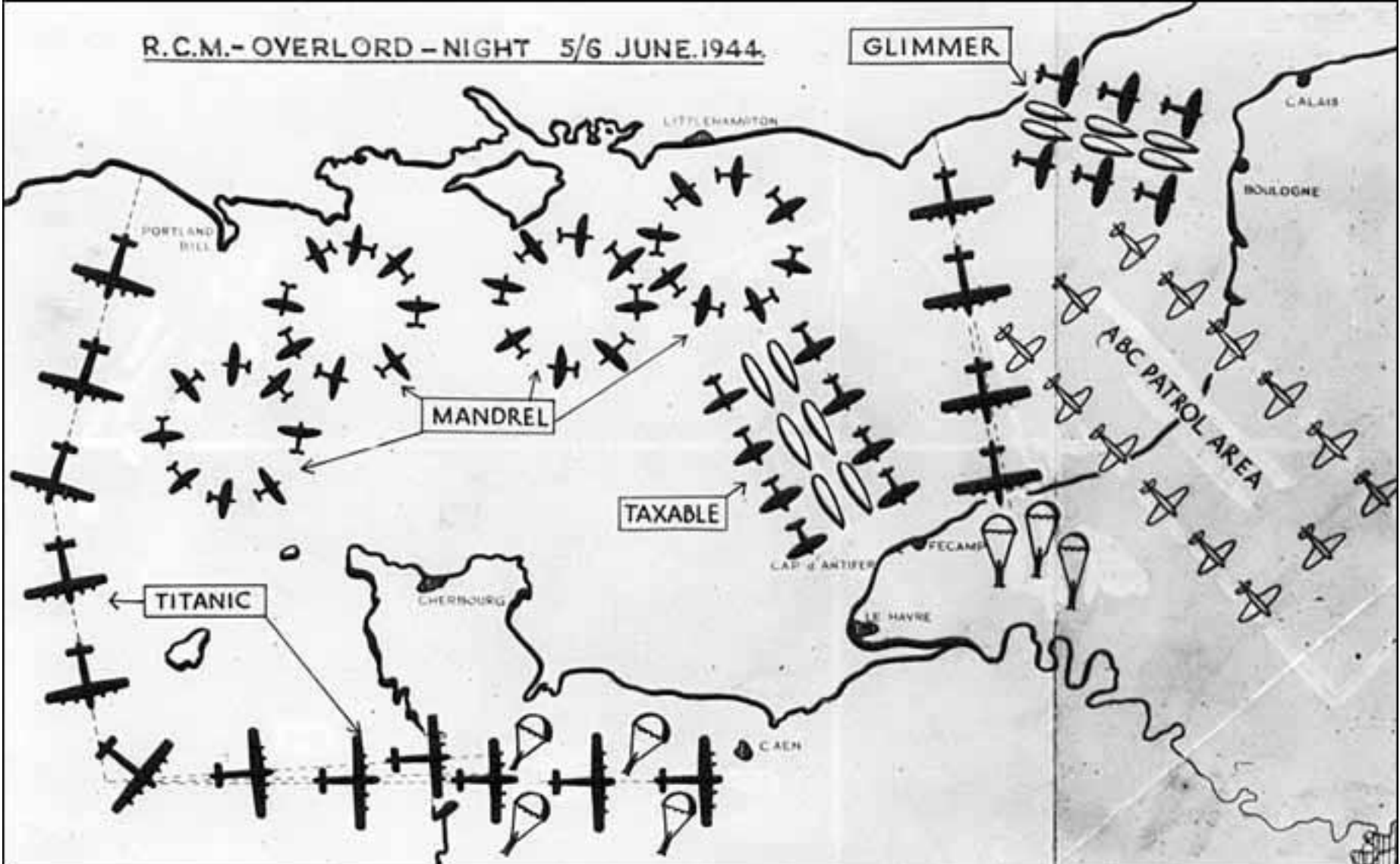

Electronic Warfare 1944/45

- chaff
- ELINT
- GCI Jamming
- Flak Jamming

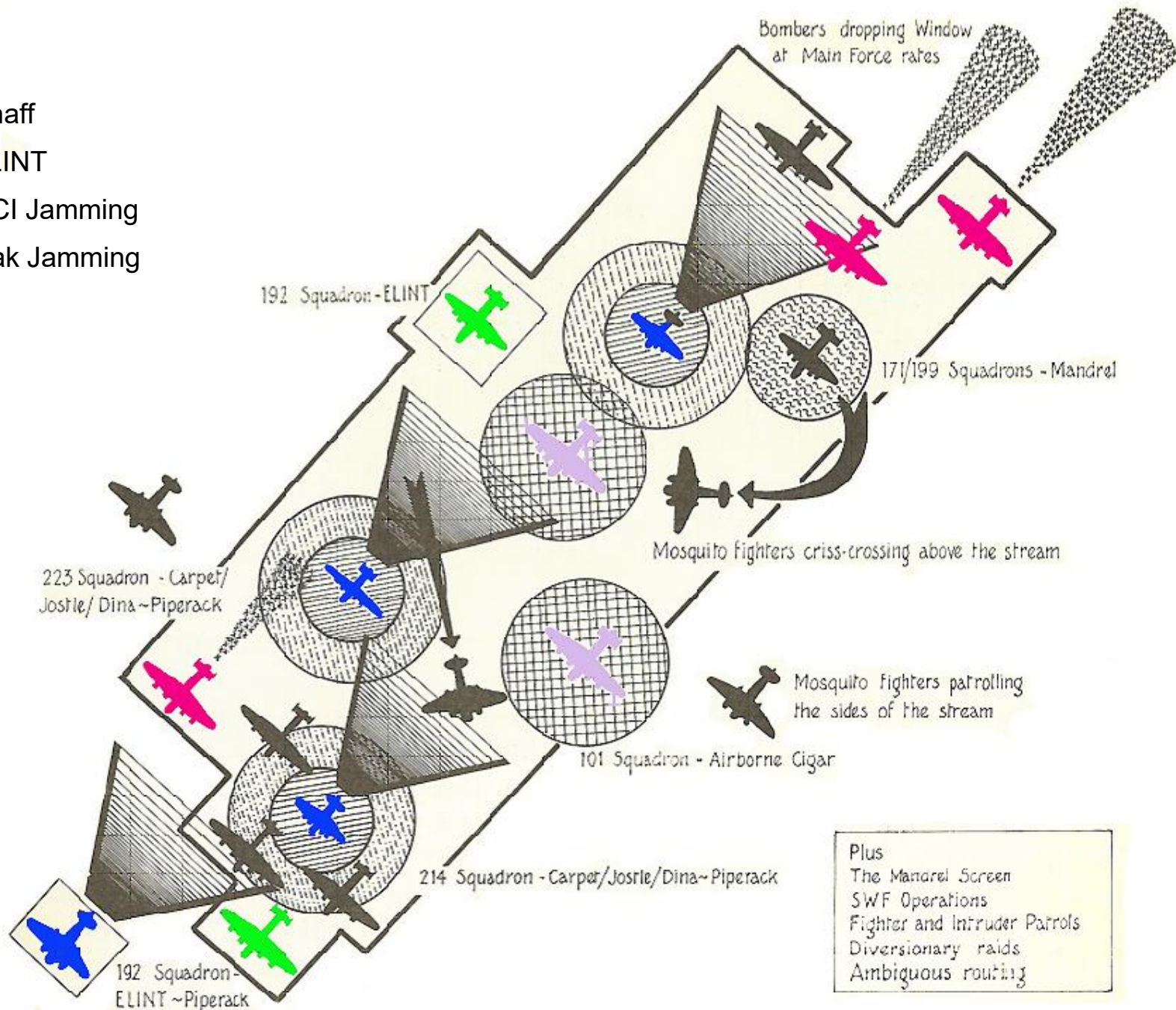

Airborne Radar In the Pacific War

B29A - H2X in the Pacific- AN/APQ-13

- H2X bombing radar also went to war in the Pacific, combined with a Bell airborne search system in a package
- Japanese cities were generally on coastlines, which made them excellent radar targets



B-29B with Eagle Radar

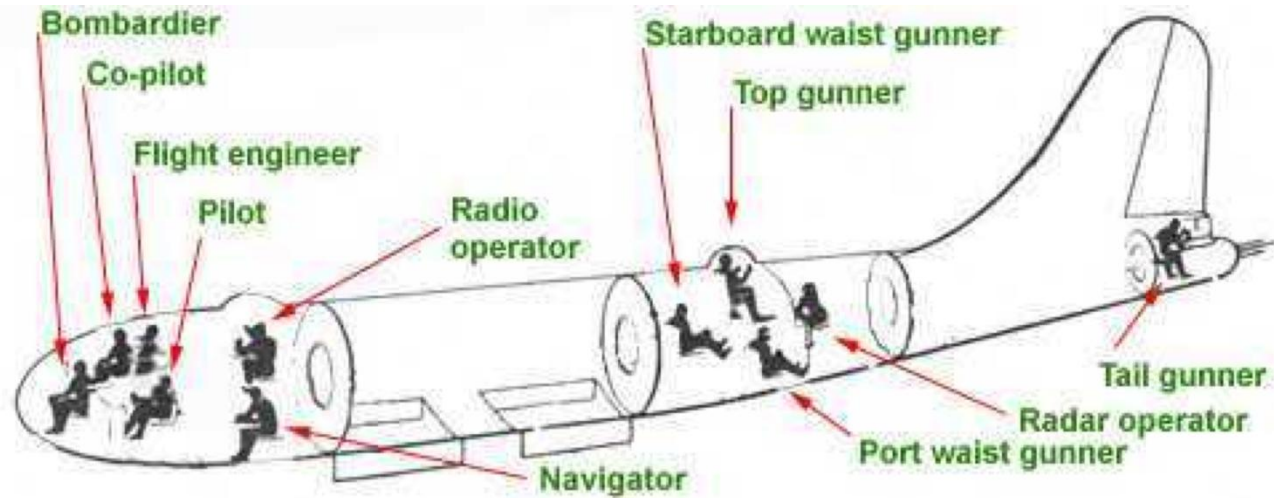
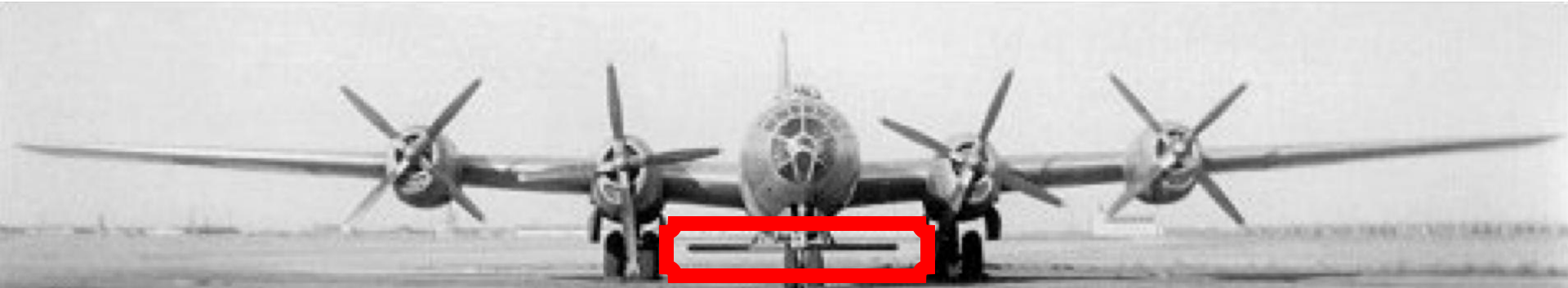

Eagle Bombing Radar AN/APQ-7

- X-band at 3 cm / 10 GHz
- Wing-like antenna that was carried below the B-29
- Designed radar beam to focus into a tall and narrow swath, ideal for targeting 60 degrees in front of the aircraft
- linked up to the Norden bombsight,.
- Deployed May 1945

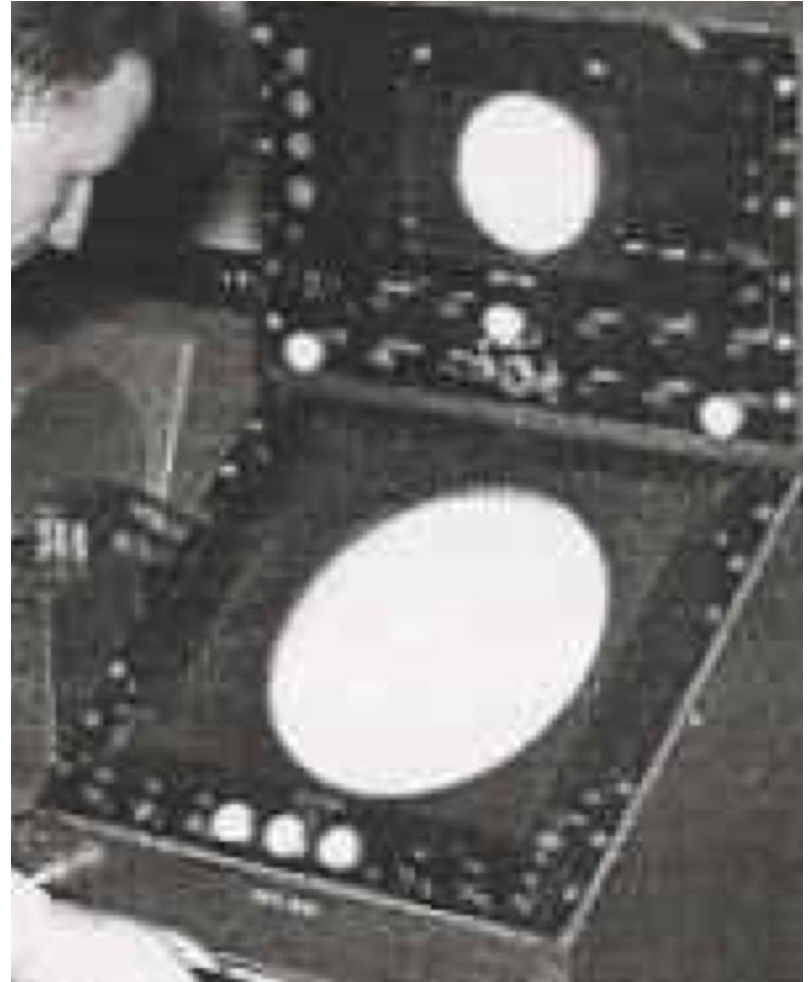



Who Ran this Secret Lab and became the Father of Electronic Warfare?

- Harvard Radio Research Lab
 - Ran all electronic warfare in WWII
 - 800 people
- Director: **Fredrick Terman - Stanford**



Who Ran this Secret Lab and became the Father of Electronic Warfare?

- Harvard Radio Research Lab
 - Separate from MIT's Radiation Laboratory
 - Ran all electronic warfare in WWII
 - 800 people
 - 1941-1944
- Director: Fredrick Terman - Stanford



Fredrick Terman

“the Father of Silicon Valley”

- Stanford Professor of engineering 1926
 - encouraged his students, William Hewlett and David Packard to start a company
- Dean of Engineering 1946
- Provost 1955

Story 3:

Berkeley Applies Physics

WWII Berkeley Experimental Physics

- Radiation Laboratory
 - Lawrence and the Cyclotron
 - Particle accelerator
 - 11” 1931 to 184” 1942
 - Beginnings of Federal Funding of “Big Science”



WWII Berkeley Theoretical Physics

- Robert Oppenheimer
- Glenn Seaborg **Nobel Prize**
- Edwin McMillan **Nobel Prize**
- Robert Serber
- Luis Alvarez **Nobel Prize**
- Emile Segre **Nobel Prize**
- Herbert York
- Wolfgang Panofsky
- Bomb feasibility study summer 1942, LeConte Hall
 - Hans Bethe, Edward Teller, John Van Vleck, Robert Serber, Felix Bloch, Stanley Frankel, Emil Konopski, Richard Tolman and John H. Van Vleck

Berkeley Nobel Prizes

- 1931 Cyclotron
 - Ernest O. Lawrence (1939 Nobel Prize in Physics)
- 1941 Plutonium and Transuranic elements:
 - Glenn Seaborg and Ed McMillan (1951 Nobel Prize in Chemistry)
- 1952 Anti-Proton
 - Owen Chamberlain, Emilio Segrè (1959 Nobel Prize in Physics)
- 1952 Bubble Chamber
 - Donald Glaser (1960 Nobel Prize in Physics)
- 1961 Carbon 14
 - Melvin Calvin (Nobel Prize in Chemistry)
- 1957 Laser
 - Charles Townes (1964 Nobel Prize in Physics)
- 1964 Hydrogen Bubble Chamber
 - Luis Alvarez (1968 Nobel Prize in Physics)

Berkeley Theory and Experimental Physics



Lawrence Livermore National Laboratory

- 2nd Nuclear Weapons Lab
 - Competitor to Los Alamos
 - Run by Berkeley
- founded in 1952
 - By Edward Teller / Ernest Lawrence,
 - Originally a branch of the Berkeley Radiation Lab
- At Berkeley Innovation was focused inward



Story 4:

Stanford And The Cold War

WWII Office of Scientific Research and Development (OSRD)

- \$450 million spent on weapons R&D
 - MIT \$117 million
 - Caltech \$83 million
 - Harvard and Columbia ~ \$30 million
- Stanford ~ **\$50K**

Story 3: Spook Entrepreneurship

WWII Office of Scientific Research and Development (OSRD)

- \$450 million spent on weapons R&D
- Scientist in universities designed the weapons
 - MIT \$117 million
 - Caltech \$83 million
 - Harvard and Columbia ~ \$30 million
- Stanford ~ \$50K

WWII - Office of Scientific Research and Development (OSRD)

1941-1947



19 divisions
5 committees
2 panels

WWII - Office of Scientific Research and Development (OSRD)

1941-1947



19 divisions
5 committees
2 panels

Division 1 Ballistic Research	Division 2 Impact and Explosion Effects	Division 3 Rocket Ordnance	Division 4 Ordnance Accessories	Division 5 New Missiles
Division 6 Sub-surface Warfare (Sonar)	Division 7 Fire Control	Division 8 Explosives	Division 9 Chemistry	Division 10 Absorbents and Aerosols
Division 11 Chemical Engineering	Division 12 Transportation	Division 13 Electrical Communication	Division 14 Radar	Division 15 Radio Coordination Electronic Warfare
Division 16 Optics/Camouflage	Division 17 Physics	Division 18 War Metallurgy	Division 19 Misc	

Applied Math Panel	Applied Psychology Panel		Vacuum Tube Committee
	Division 1 Medicine	Division 2 Surgery	Division 3 Aviation Medicine
Administrative Committee	Division 4 Tropical Diseases	Division 5 Committee on Medical Research	Division 6 Malaria

WWII - Office of Scientific Research and Development (OSRD)

1941-1947



19 divisions
5 committees
2 panels

Division 1 Ballistic Research	Division 2 Impact and Explosion Effects	Division 3 Rocket Ordnance	Division 4 Ordnance Accessories	Division 5 New Missiles
Division 6 Sub-surface Warfare (Sonar)	Division 7 Fire Control	Division 8 Explosives	Division 9 Chemistry	Division 10 Absorbents and
Division 11 Chemical Engineering	Division 12 Transportation	Division 13 Electrical Communication	Division 14 Radar	Division 15 Radio Coordination Electronic Warfare
Division 16 Optics/Camouflage	Division 17 Physics	Division 18 War Metallurgy	Division 19 Misc	

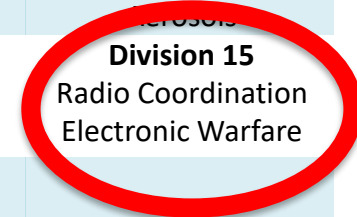

Applied Math Panel	Applied Psychology Panel		Vacuum Tube Committee
		↓	
	Division 1 Medicine	Division 2 Surgery	Division 3 Aviation Medicine
Administrative Committee	Division 4 Tropical Diseases	Division 5 Committee on Medical Research	Division 6 Malaria

Research Universities

\$5.5 billion

Office of Scientific Research (OSRD)

- MIT \$1.4 billion
- Caltech \$1 billion
- Harvard \$370 million
- Columbia \$370 million
- Stanford \$6 million

All in adjusted 2011 dollars
Source: Scientists Against Time: 456

Division 1 Ballistic Research	Division 2 Impact and Explosion Effects	Division 3 Rocket Ordnance	Division 4 Ordnance Accessories	Division 5 New Missiles
Division 6 Sub-surface Warfare	Division 7 Fire Control	Division 8 Explosives	Division 9 Chemistry	Division 10 Absorbents /Aerosols
Division 11 Chemical Engineering	Division 12 Transportation	Division 13 Communication	Division 14 Radar	Division 15 Electronic Warfare
Division 16 Optics and Camouflage	Division 17 Physics	Division 18 War Metallurgy	Division 19 Misc	

Applied Math Panel	Applied Psych Panel	Propagation Committee	Vacuum Tube Committee
Administrative Committee	Tropical Committee	Committee on Medical Research	

Division 1 Medicine	Division 2 Surgery	Division 3 Aviation Medicine
Division 4 Physiology	Division 5 Chemistry	Division 6 Malaria

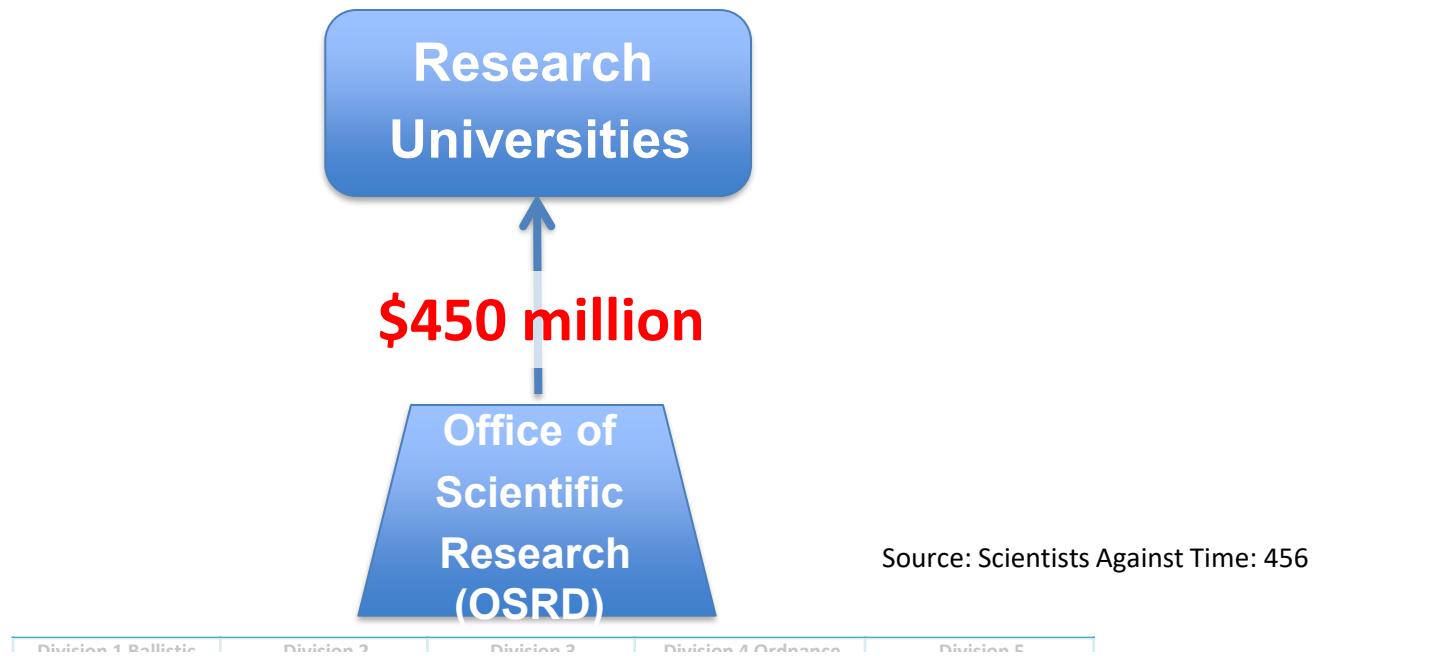

\$450 million spent on weapons R&D

- MIT \$117 million
- Caltech \$83 million
- Harvard and Columbia ~ \$30 million
- Stanford ~ **\$50K**

Physiology	Chemistry	Malaria
------------	-----------	---------



1950

Division 1 Ballistic Research	Division 2 Impact and Explosion Effects	Division 3 Ordnance	Division 4 Ordnance Accessories	Division 5 New Missiles
Division 6 Sub-surface Warfare (Sonar)	Division 7 Fire Control	Division 8 Explosives	Division 9 Chemistry	Division 10 Absorbents and Aerosols
Division 11 Chemical Engineering	Division 12 Transportation	Division 13 Electrical Communication	Division 14 Radar	Division 15 Radio Coordination Electronic Warfare
Division 16 Optics and Camouflage	Division 17 Physics	Division 18 War Metallurgy	Division 19 Misc	



National Science Foundation (NSF)

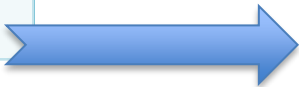

Atomic Energy Commission (AEC)

Applied Math Panel	Applied Psychology Panel		Vacuum Tube Committee
		↓	
Division 1 Medicine	Division 2 Surgery		Division 3 Aviation Medicine
Division 4 Physiology	Division 5 Chemistry		Division 6 Malaria
Administrative Committee	Tropical Deterioration Committee	Committee on Medical Research	

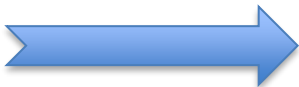

Department of Defense (DOD)

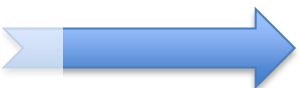

National Institute of Health (NIH)

Office of
Scientific
Research (OSRD)

Division 1 Ballistic Research	Division 2 Impact and Explosion Effects	Division 3 Rocket Ordnance	Division 4 Ordnance Accessories	Division 5 New Missiles
Division 6 Sub-surface Warfare (Sonar)	Division 7 Fire Control	Division 8 Explosives	Division 9 Chemistry	Division 10 Absorbents and Aerosols
Division 11 Chemical Engineering	Division 12 Transportation	Division 13 Electrical Communication	Division 14 Radar	Division 15 Radiology and Electronics
Division 16 Optics and Camouflage	Division 17 Physics	Division 18 War Metallurgy	Division 19 Misc	

1958

National Science Foundation (NSF)

National Aeronautics & Space Admin (NASA)

Atomic Energy Commission (AEC)
to DOE in 1977

Defense Advanced Research Projects Agency (DARPA)

Department of Defense (DOD)

National Institute of Health (NIH)

Applied Math Panel	Applied Psychology Panel		Vacuum Tube Committee
		↓	
Division 1 Medicine	Division 2 Surgery	Division 3 Aviation Medicine	
Division 4 Physiology	Division 5 Chemistry	Division 6 Malaria	
Administrative Committee	Tropical Deterioration Committee	Committee on Medical Research	



Terman's Postwar Strategy

- Focus on microwaves and electronics
 - Not going to be left out of gov' t \$' s this time
- Recruits 11 members of war lab as faculty
- By 1950 Stanford was the MIT of the West
- Students came from all over the U.S.



Terman's Postwar Strategy

- Focus on microwaves and electronics
 - Not going to be left out of gov' t \$' s this time
- Recruits 11 former members of RRL as faculty
- Set up the Electronics Research Laboratory (ERL)
 - “Basic” and Unclassified Research
- First Office of Naval Research (ONR) contract 1946
- By 1950 Stanford was the MIT of the West



Terman Reassembles RRL at Stanford

- Recruits 11 former members of RRL as faculty
- Set up the Electronics Research Laboratory (ERL)
 - part of the Engineering Department
 - “Basic” and Unclassified Research
- First Office of Naval Research (ONR) contract 1946
- By 1950 Stanford was the MIT of the West

Microwave Valley - Stanford Spinouts

Microwave Components

- Microwave Tube Startups:
Klystrons, BWO's, & TWT's
 - Eitel-McCullough (1934)
 - Varian Associates (1948)
 - Litton Industries (1946)
 - Huggins Laboratories (1948)
 - Stewart Engineering (1952)
 - Watkins-Johnson (1957)
 - Microwave Electronics Co. (1959)



Microwave Valley - Components

Klystrons, Carcinotrons, & Traveling Wave Tubes

- Eitel-McCullough (1934)
- Varian Associates (1948)
- Litton Industries (1946)
- Huggins Laboratories (1948)
- Stewart Engineering (1952)
- Watkins-Johnson (1957)
- Microwave Electronics Co. (1959)



Problem: Jammers Need: *More Power and Frequency Agility*

- *More Power*
 - WWII: low power jammers X 100' s of planes
 - Now each bomber needed to protect itself
- *Frequency Agility*
 - WWII radars xmitted on a single frequency
 - Jammers needed to be manual tuned
 - Soviet radars used multiple frequencies

Solution: Electronically Tunable Microwave Power Tubes

- Magnetron - limited scale, fixed/unstable freq
- Klystron - scale to extremely high power
 - Drawback: narrow frequency range
- Backward wave oscillator (BWO)/Carcinotron
 - Electronically tunable
 - Can sweep 1000/mhz per second
 - High Power ~1,000 watts

Problem: ELINT Receivers Need: *Higher Bandwidth & Frequency Agility*

- *High Bandwidth*
 - Need to cover 300mhz to 40ghz w/one receiver
- *Frequency Agility*
 - Soviet radars used multiple frequencies
 - Manual tuning would miss signals
 - Needed high probability of intercept single pulses

Solution: Electronically Tunable Wideband Amplifiers

- Traveling Wave Tubes
 - High gain $>40\text{db}$,
 - low noise,
 - high bandwidth >1 octave
 - $300\text{mhz} - 50\text{ghz}$
 - Tune at 1000mhz/sec

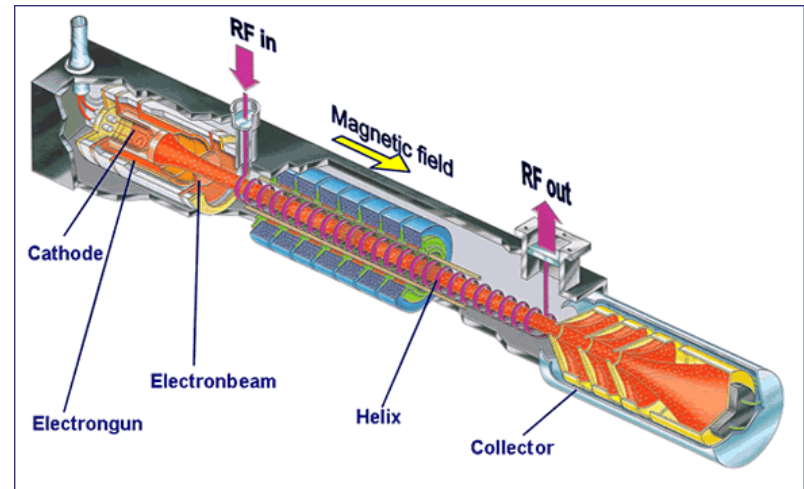



Korean War Changes the Game

Spook Work Comes to Stanford

- Applied Electronics Laboratory (AEL)
 - “Applied” and Classified Military programs
 - Doubles the size of the electronics program
 - Separate from the unclassified Electronics Research Laboratory
 - Made the university, for the first time, a full partner in the military-industrial complex



The Cold War and the *Black Valley*

- The Cold War battlefield moves 500 miles east
- Fear of a “nuclear Pearl Harbor”
- Countermeasures, Elint and Sigint, become critical
- Stanford becomes a center of excellence for the NSA, CIA, Navy, Air Force



The Cold War is an Electronic War

- Russian air defense modeled after Germans
 - add surface to air missiles, fighter radar, IFF
 - Understand and defeat (ELINT)
- Soviet strategic missile and bomber threat
 - Monitor telemetry (SIGINT) to understand performance
 - Photo reconnaissance to find silo's and bombers
- Soviet Naval threat
 - Monitor and track soviet submarines
- Soviet Nuclear threat
 - Identify and understand production facilities

Stanford Technical Advisory Meetings

- Air Force, Navy, Army, CIA and NSA
- Sylvania, and other contractors
- Review of projects and new concepts

PROGRAM		
THURSDAY, August 18, 1955		
9:00-9:30	Registration	ERL Lobby
9:40-12:00	SESSION I (Chairmen: F. E. Terman, D. B. Harris, K. R. Spangenberg) Introduction Program of the Meeting Operation of the Laboratories The Research Program 1. Radio Propagation 2. Transistors; Circuits and Devices	Geology Bldg., Rm. 320 F. E. Terman D. B. Harris K. R. Spangenberg O. G. Villard J. M. Pettit
10:30-10:55	Recess	
	3. High-Power Tubes and Accelerators 4. Backward-Wave Tubes and TW Tubes 5. Systems Techniques Announcements	E. L. Ginzton D. A. Watkins W. R. Rambo D. B. Harris
12:00-1:30	Recess	
1:30-2:50	SESSION II-A Systems Techniques I SESSION II-B Klystrons	Geology Bldg., Rm. 320 ERL, Rm. 126
2:50-3:10	Recess	
3:10-4:30	SESSION III-A Radio Propagation and Ionospheric Research SESSION III-B Traveling-Wave Tubes	Geology Bldg., Rm. 320 ERL, Rm. 126
FRIDAY, August 19, 1955		
9:30-10:40	SESSION IV-A Transistors and In- formation Theory SESSION IV-B Backward-Wave Tubes	Geology Bldg., Rm. 320 ERL, Rm. 126
10:40-11:00	Recess	
11:00-12:10	SESSION V-A Systems Techniques II SESSION V-B High-Power TW Tubes	Geology Bldg., Rm. 320 ERL, Rm. 126
12:10-1:30	Recess	
1:30-2:00	SESSION VI General Discussion	Geology Bldg., Rm. 320
2:00-	SESSION VII Tour of the Laboratories	

Stanford Joins the “Black” World

- Electronics Research Laboratory
 - “Basic” and Unclassified Research
- Applied Electronics Laboratory (AEL)
 - “Applied” and Classified Military programs
- Merge and become the Systems Engineering Lab (SEL) in 1955
 - Same year Terman becomes Provost

Top Secret/SI/TK/Q3

Stanford Systems Engineering Lab

- Immediate, practical application of real world intelligence problems for CIA, NSA, NRO, Air Force
- Combined ERL components with advanced theory into complete SIGINT and Jamming *systems*
 - Usually prototypes turned over to contractors
 - At times, built one-off systems
 - Digital filtering, OTH, etc.
- Use PhD students and staff
 - classified thesis!
- Ultimately 800 person lab

Stanford Helps Understand the Electronic Order of Battle (EOB)

- Where are the Soviet radars?
 - Consumers; SAC, CIA.
- Technical details of the radars
 - NSA/CIA to contractors
- Periphery of Soviet Union known
- Interior terra incognita



Problem: Understand the Soviet Radar Order of Battle

- Where are the Soviet radars?
 - Consumers; SAC, CIA.
- Details of the radars
 - NSA/CIA to contractors
- Periphery of Soviet Union known
- Interior terra incognita



Terman Changes the Startup/University Rules

- Graduate students encouraged to start companies
- Professors encouraged to consult for these companies
- Terman and other professors take board seats
- Technology transfer/IP licensing easy
- Getting out in the real world was good for your academic career



B-52 Bomber Strike on Severodvinsk

B-52G: 2 AGM-28 Cruise Missiles 1.1 MT
1 B-53 9 MT gravity bomb



© 2010 Tele Atlas
Image IBCAO
© 2010 Geocentre Consulting
Image © 2010 TerraMetrics

© 2009 Google



Eye alt 1154.75 mi

B-52 Bomber Strike on Severodvinsk

 B-52G
 TALL KING Early Warning Radar:
Range ~300 miles



B-52 Bomber Strike on Severodvinsk

-  B-52G
-  TALL KING
-  SA-5 Surface to Air Missile:
Range 10-100 miles
Altitude 1,000 - 60,000 feet

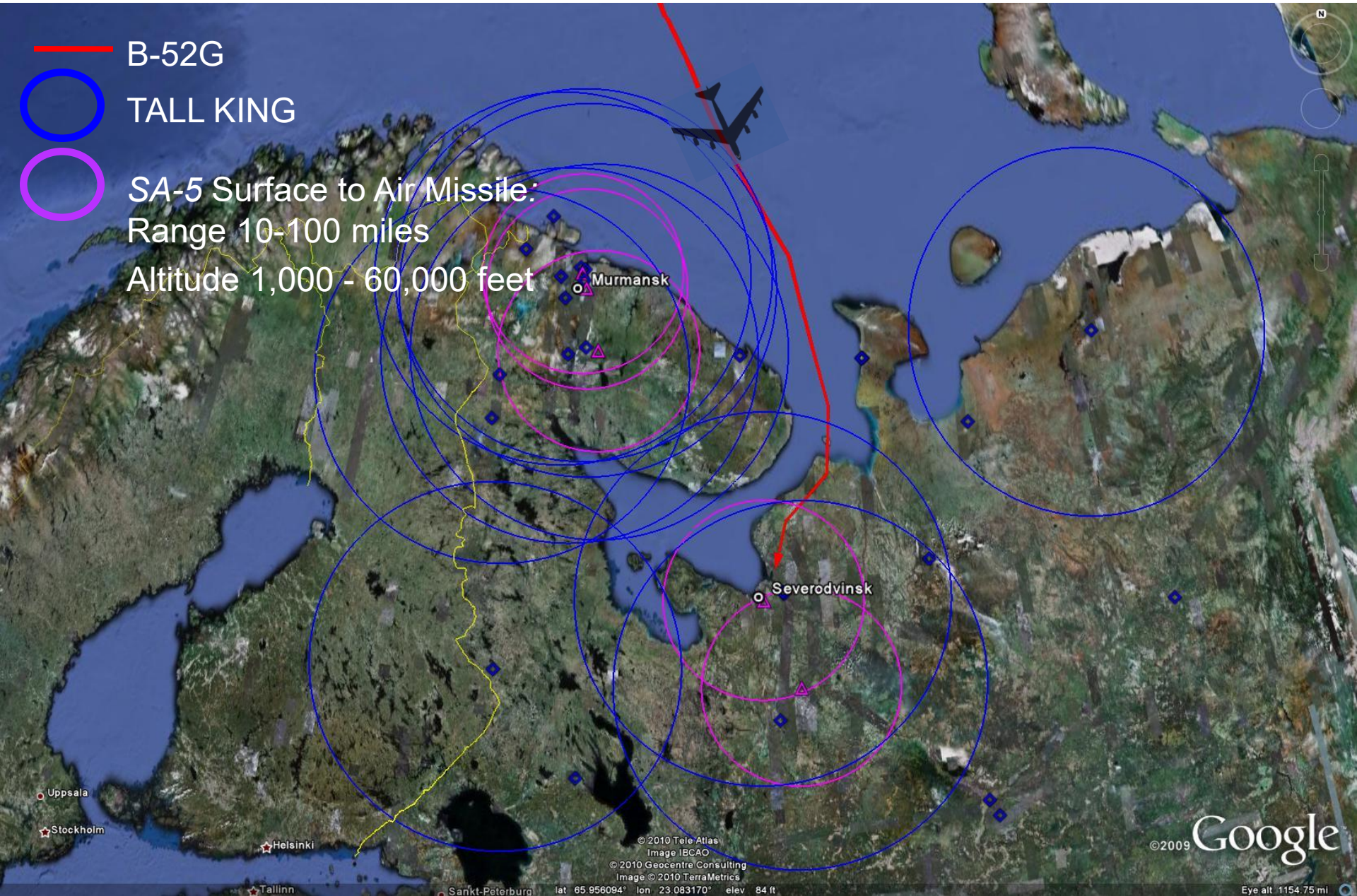

B-52 Bomber Strike on Severodvinsk

-  B-52G
-  TALL KING
-  SA-5

AGM-28: Nuclear Cruise Missile
1.1 MT weapon, Mach 2

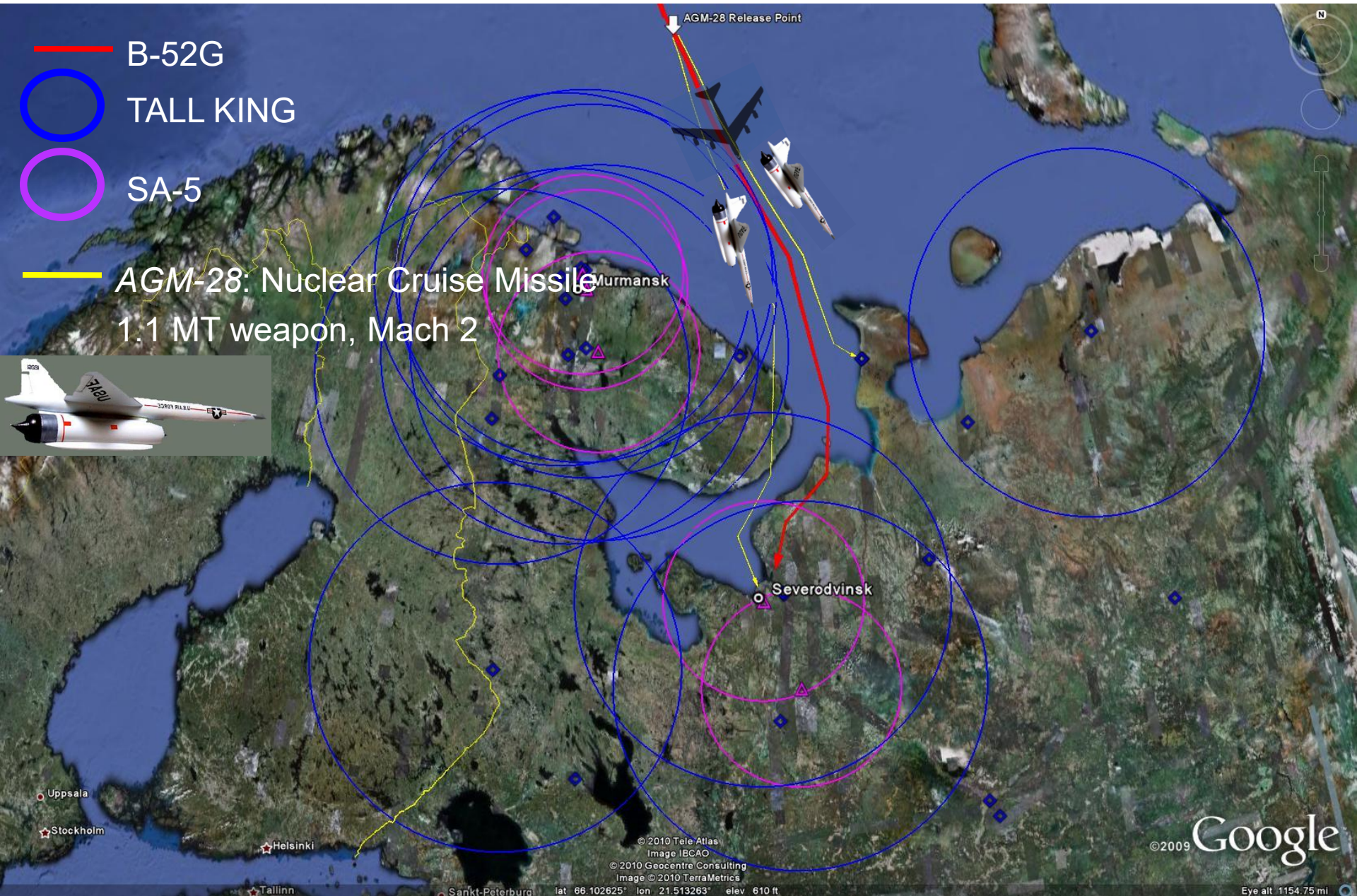

AGM-28 Hound Dog – Cruise Missile



- Carried under the wing of a B-52, two per bomber
- Launched at 45,000, climb to more than 56,000 feet, Mach 2 cruise to the target and then dive to the target
- 1.1 MT nuclear weapon
- Range ~ 700 miles

B-52 Bomber Strike on Severodvinsk

- B-52G
- AGM-28

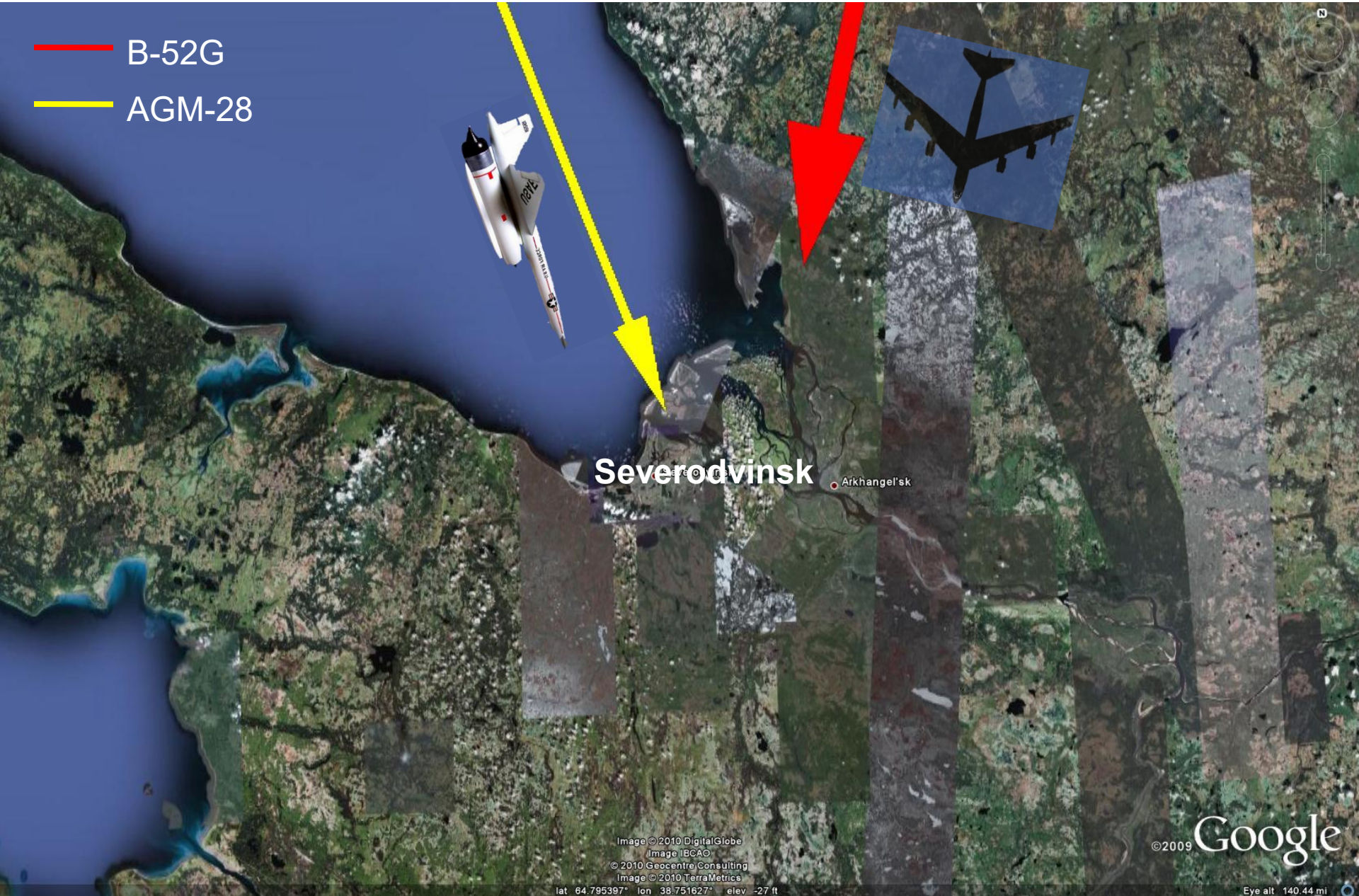

Image © 2010 DigitalGlobe
Image IBCAO
© 2010 Geocentre Consulting
Image © 2010 TerraMetrics
lat 64.795397° lon 38.751627° elev. -27 ft

© 2009 Google

Eye alt 140.44 mi

B-52 Bomber Strike on Severodvinsk

— B-52G

— AGM-28

○ SA-2 Surface to Air Missile:
Range 5 – 25 miles
Altitude 1,250 - 90,000 feet

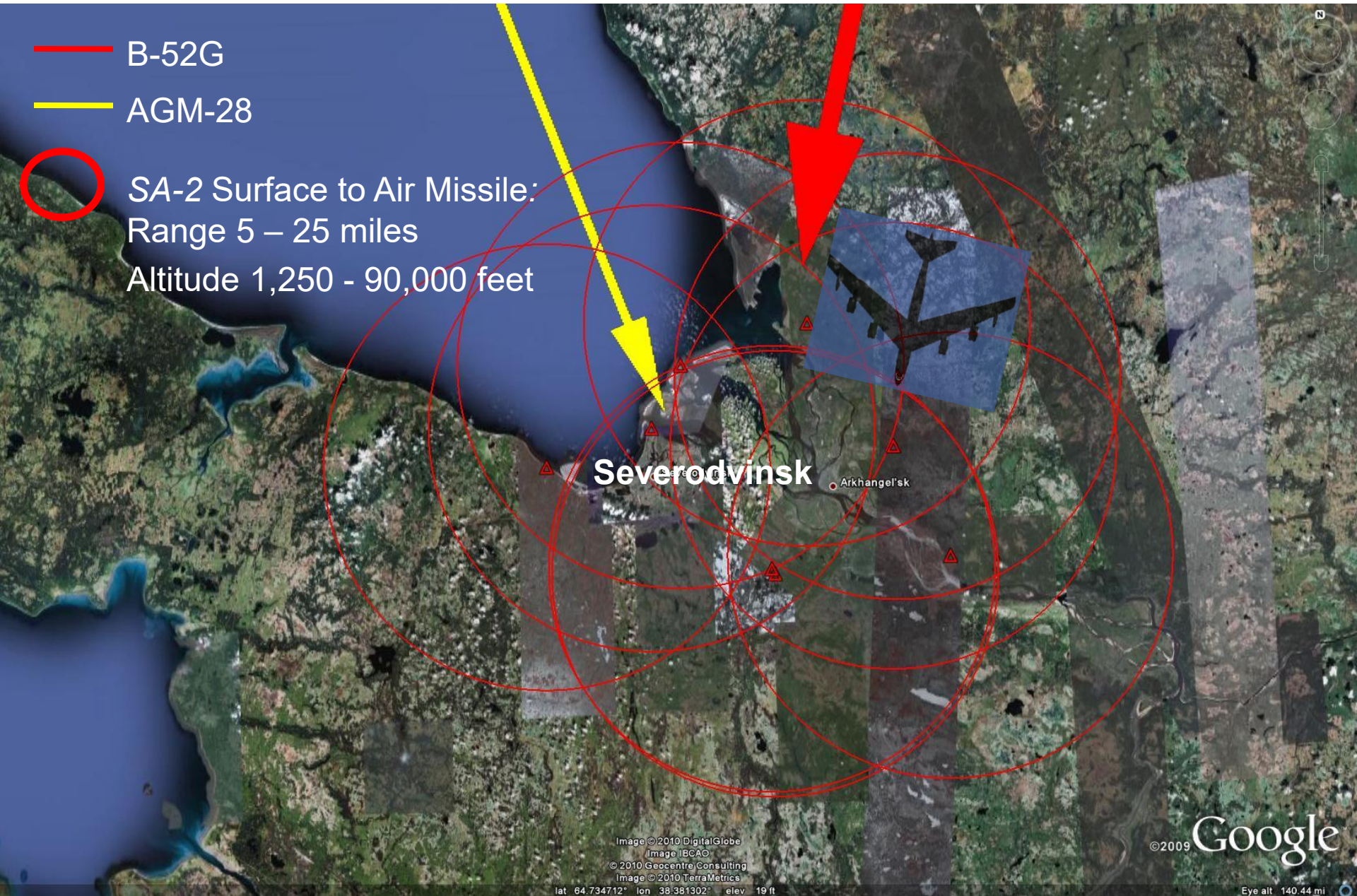

Surface to Air Missile Defense of Severodvinsk



B-52 Bomber Strike on Severodvinsk

— B-52G

— AGM-28

○ SA-2

○ SA-3 Surface to Air Missile:
Range 2.5 – 15 miles
Altitude 60 - 54,000 feet

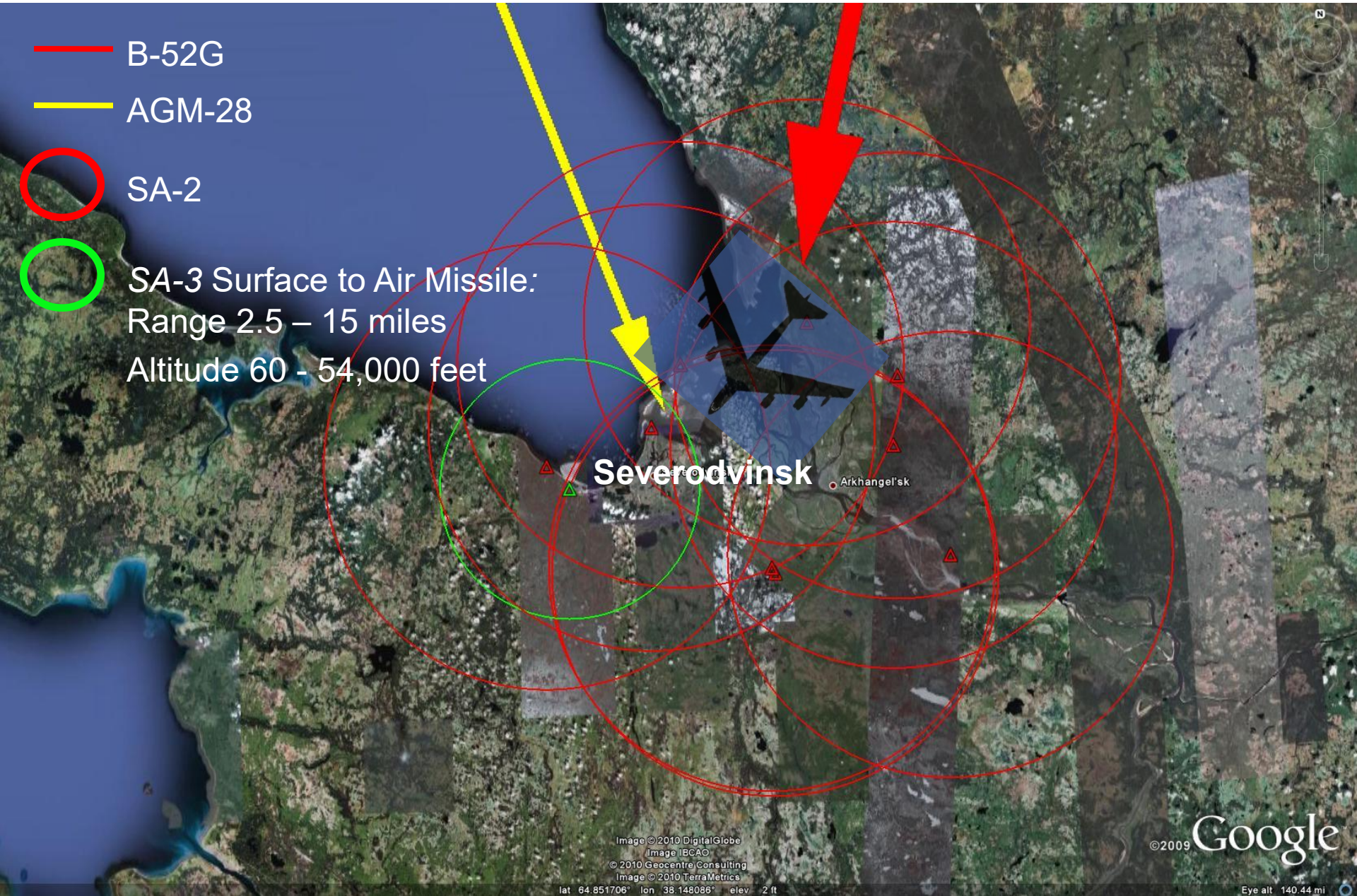

B-52 Bomber Strike on Severodvinsk

— B-52G

— AGM-28

○ SA-2

○ SA-3

○ SA-5 Surface to Air Missile:
Range 10 – 100 miles
Altitude 1,000 – 60,000 feet

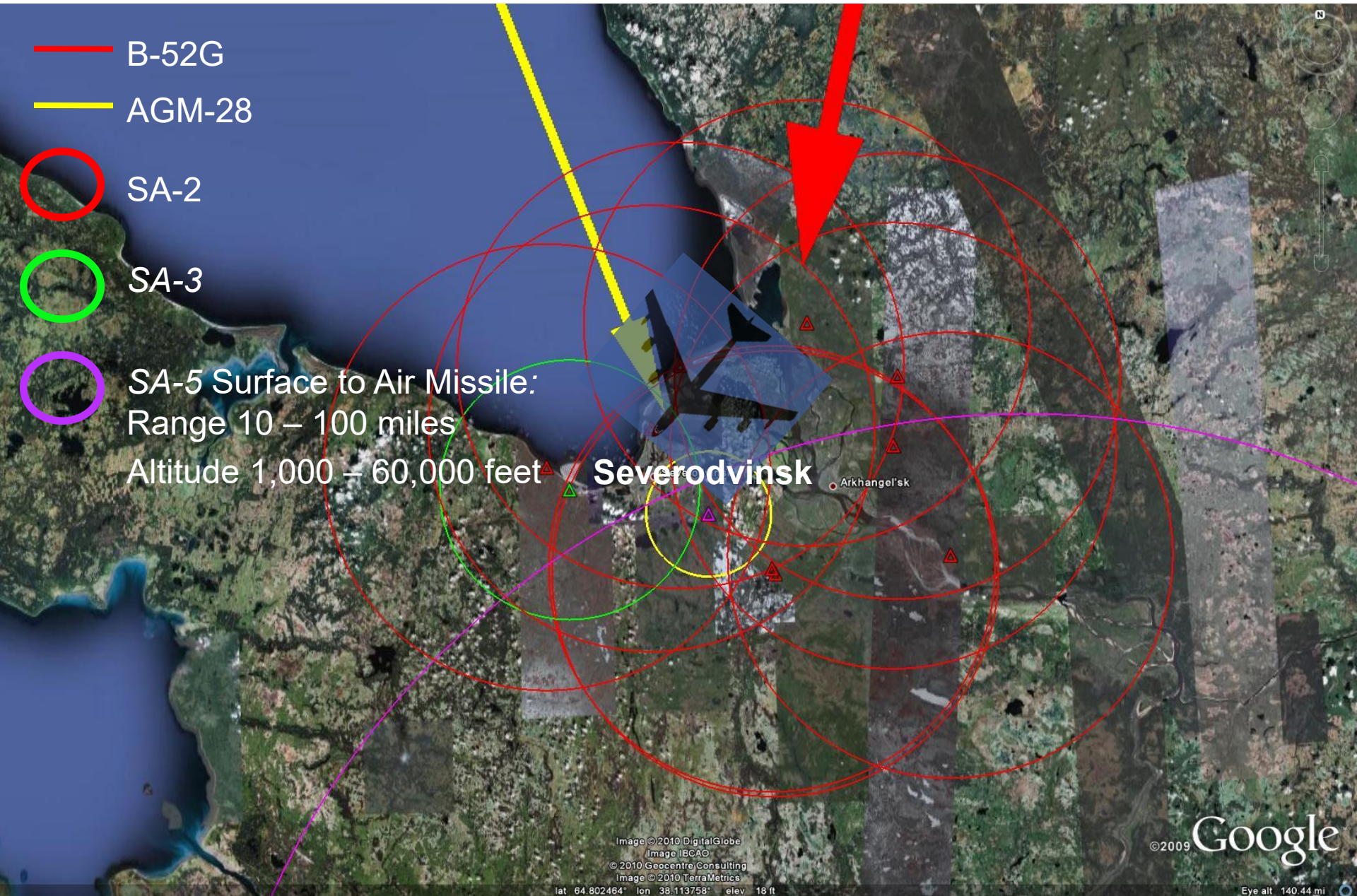

Image © 2010 DigitalGlobe
Image IBCAO
© 2010 Geocentre Consulting
Image © 2010 TerraMetrics
lat 64.802464° lon 38.113758° elev. 18 ft

© 2009 Google

Eye alt 140.44 mi

SIGINT Collection Goes 24/7

- NSA gets SIGINT mission
- Service Cryptologic Elements
 - Air Force Security Service
 - Naval Security Group
 - Army Security Agency
 - Eventually the Central Security Service
- Targets were the Soviet Block
- Most data was from denied areas – outside the U.S.



1950' s Solution: Fleet of SIGINT Planes

- Flew periphery of Soviet bloc 24/7
 - PB4Y2, P2V, C-97, RB-47, EC-121, C-130, EA-3B, RC-135
- Measured Soviet Air Defense
 - Revealed low-altitude coverage was good
- Continuous COMINT and targeted SIGINT



SIGINT– *The Line of Sight Problem*

You got to get close!

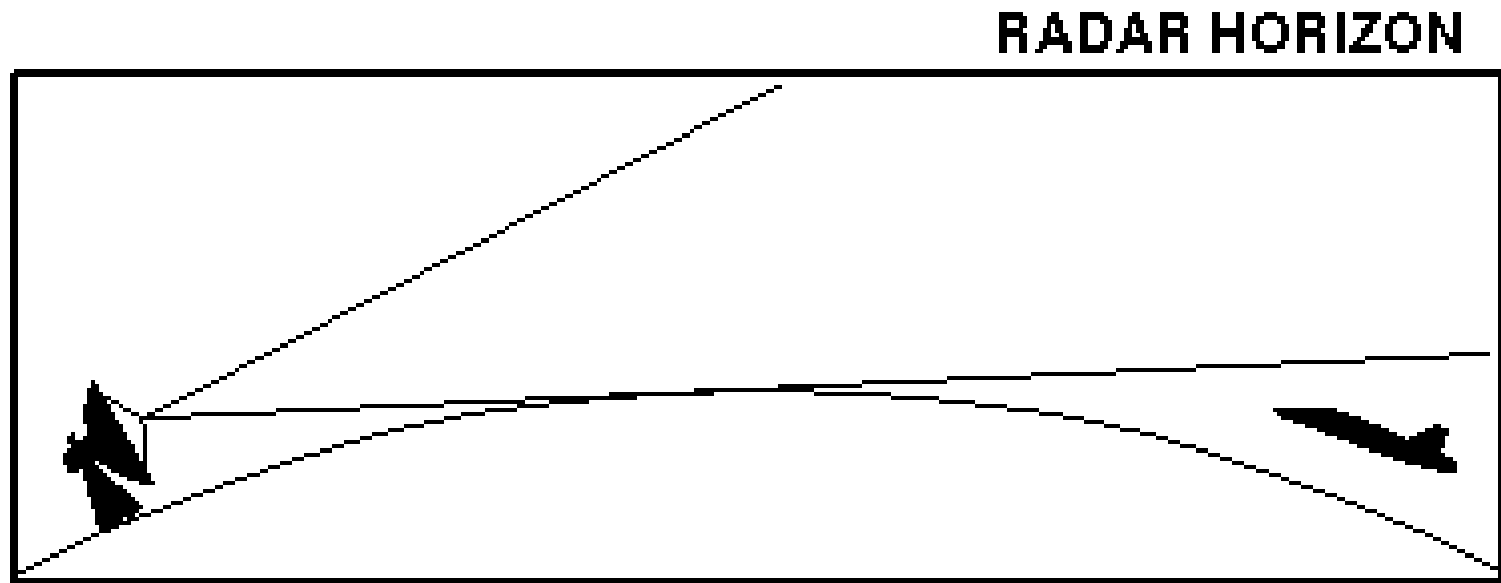

You got to get them turned on!!

The Cost: 23 SIGINT Planes

Date	Victim	Service	Aircraft	Pilot	Weapon
8Apr50	PB4Y-2	USN	La-11	B.Dokin	23/37mm
24Apr50	F-82	USA F	MiG-15	Keleinikov	23/37mm
Apr50	F-51D	USA F	MiG-15	N.Guzhov	23/37mm
May50	F-51D	USA F	La-11	Yefremov	20mm
11May50	B-24	USA F	MiG-15	I.Shinkarenko	23/37mm
26Dec50	RB-29	USA F	MiG-15	S.Bhakaev	23/37mm
6Nov51	P2V-2	USN	MiG-15	M.Schukin	23/37mm
13Jun52	RB-29	USA F	MiG-15	O.Fedotov	23/37mm
7Oct52	RB-29	USA F	MiG-15	Zheryakov	23/37mm
7Oct52	RB-29	USA F	MiG-15	Lesnov	23/37mm
29Jul53	RB-50	USA F	MiG-15	A.Rybakov	23/37mm
4Sep54	P2V-5	USN	MiG-15	?	23/37mm
7Nov54	RB-29	USA F	MiG-15	Kostin	23/37mm
17Apr55	RB-47H	USA F	MiG-15	Korotkov	23/37mm
22Jun55	P2V-5	USN	MiG-15	?	23/37mm
10Sep56	RB-50	USA F	MiG-15	?	23/37mm
27Jun58	C-118	USA F	MiG-17 P	Sevetlichnikov	23/37mm
2Sep58	C-130A	USA F	MiG-17	H.Gavrilov	23/37mm
1Jul60	RB-47	USA F	MiG-17 F	V.Polyakov	23/37mm
1963	RB-47	USA F	MiG-19 S	?	30mm
1963	T-39	USA F	MiG-19 S	?	30mm
10Mar64	RB-66C	USA F	MiG-21F-13	Zinowljev	30mm
14Dec65	RB-57F	USA F	MiG-17 F	?	23/37mm

Reconnaissance Aircraft attacked, damaged or shot down

Date	Type	Unit	Location	Claimed By	Notes
15 Nov 45	PBM-5	USN	Port Arthur	Unknown	Shot at but escaped
20 Feb 46	PBM-5	USN VP-26	Darien	Unknown	Damaged but escaped
22 Apr 46	C-47	USAAF	Tullin, Nr Vienna	Shot at but escaped	None
9 Aug 46	C-47	USAAF	Ljubljana, Yugoslavia	Dragomir Zecevic in a YAK-3	Shot at and crash landed 5 Survivors
19 Aug 46	C-47	USAAF	Near Bled Yugoslavia	Vladimir Vodopivec in a YAK-3	5 Fatalities
1946	Dakota	RAF	Near Nis Yugoslavia	Zeljko Cernelj in a YAK-3	Forced to land
27 Oct 48	P-38 Lightning	Italian Air Force	Yugoslavia	Unknown	Disappeared on a sortie
7 Jan 49	Spitfire FR18 x 4	Royal Air Force	Sinai near Faluja	Israel Spitfires	Shot down on a recce sortie
22 Oct 49	RB-29	USAF	Sea of Japan	Shot at but escaped	None
8 Apr 50	PB4Y-2	USN	Baltic Sea	Lt Ivan, St Lt's Dokin, Gerasimov & Lt Sataev all in La-11s	10 Fatalities at least 8 crewmembers were sighted in prison, but all subsequently disappeared
24 Apr 50	P-38	USAAF	Unknown	Mj Keleinikov claimed as shot down but unconfirmed	None
Apr 50	B-26	USAF	Unknown	P Dushin	Claimed as shot down but unconfirmed
Apr 50	B-26	USAF	Unknown	V Sidorov	Claimed as shot down but unconfirmed
Apr 50	F-51 x 2	USAF	Unknown	Nikolia N Guzhov	Claimed as shot down but unconfirmed
11 May 50	B-24	USAF	Unknown	Kap Il Shinkarenko	Claimed as shot down but unconfirmed
15 Jul 50	RB-29	USAF	Nr Permskoye airfield	Unknown	Shot at but escaped
4 Sep 50	Twin-Engined Bomber	Soviet	Korean West coast nr 38th parallel	Unknown	Approached and fired at USN formation and was then shot down crew presumed dead
8 Oct 50	F-80 x 2	USAF	Nr Vladivostok	Unknown	Allegedly strafed an airfield - unconfirmed
4 Dec 50	RB-45C	USAF	Nr Antung, N Korea	Unknown	Unknown
6 Nov 51	P2V-3	USN	Nr Vladivostok	Lukashyev & Shchukin	10 fatalities
18 Nov 51	C-47	USAF	Nr Papa in Hungary	St Lt Kalugin in MiG-15	Forced to land no casualties
1 Apr 52	Unknown	USN	China Sea	Unknown	Shot at but escaped
29 Apr 52	DC-4	Air France	Nr Berlin	Two MiG-15s	Shot at aircraft damaged, 3 wounded
13 Jun 52	RB-29	USAF	Sea of Japan	Kap Fedotov & St Lt Proskurin	12 fatalities a member of the crew was sighted in prison.
13 Jul 52	DC-3	Sweden	Baltic Sea	Kap Osinskii	Casualties unknown
16 Jun 52	PBY-5A	Sweden	Baltic Sea	Unknown	Casualties unknown
31 Jul 52	PBM-5S2	USN	Formosa	Unknown	Shot at but escaped
20 Sep 52	P4Y-2S	USN	China coast	H Zhongdao	Shot at but escaped
7 Oct 52	RB-29	USAF	Nr Kurile Islands	St Lt's Zheryakov & Leenov	8 fatalities
8 Oct 52	C-47	USAF	Nr Berlin	Unknown	Shot at but escaped
23 Nov 52	P4Y-2S	USN	Shanghai	Unknown	Shot at but escaped
29 Nov 52	C-47	CIA	China	Unknown	2 fatalities
12 Jan 53	B-29	USAF	Manchuria	Unknown	3 fatalities
18 Jan 53	P2-V5	USN	Nr Formosa	Unknown	Shot down by ground fire - 6 fatalities
10 Mar 53	F-84G	USAF	W Germany nr Czech border	Jaroslav Sramek	One F-84G shot down by a MiG-15, pilot ejected and captured

12 Mar 53	Lincoln RAF	W Germany Nr Elbe	Unknown	Shot down by Soviet MiG-15s 7 fatalities	None
17 Mar 53	Viking	BEA	Nr Berlin	Unknown	Shot at by Soviet MiG-15s but escaped
22 Mar 53	B-50	USAF	Unknown	Unknown	Shot at by Soviet MiG-15s but escaped
15 Mar 53	RB-50	USAF	Kamchatka	Unknown	Shot at by Soviet MiG-15s but escaped
29 Jul 53	RB-50	USAF	Sea of Japan near Vladivostok	St Lts Rybakov & Yablonovskii	Shot down by Soviet MiG-15s 1 survivor, 15 fatalities
Aug 53	Canberra	RAF	Near Kapustin Yar	Unknown	Aircraft shot at and damaged by MiGs - unconfirmed
17 Aug 53	T-6	USAF	Korea	Unknown	Shot down by N Korean ground fire 1 fatality, 1 survivor
2 Oct 53	PBM-5	USN	Yellow Sea	Unknown	Shot at by Soviet MiG-15s but escaped
30 Dec 53	F-86 x 4	USAF	Korea	Unknown	Shot at by four Mig-15s but escaped
27 Jan 54	RB-45C	USAF	Yellow Sea	Lt Eric Beecroft	Shot at by MiG-15s but escaped 1 MiG shot down by F-86
12 Mar 54	AD-4 x 2	USAF	Near Czech border	Unknown	Shot at by Czech MiGs but escaped
29 Apr 54	RB-46C	RAF on loan from USAF	Near Kiev	Unknown	Shot at whilst on overflight but escaped undamaged
8 May 54	RB-47	USAF	Nr Murmansk	Unknown	Exchanged gunfire with MiG-17s whilst on overflight damaged but escaped
26 May 54	B-17	RoCAF	China	Unknown	Shot Down over Fujian by PLA AAA - 4 fatalities
3 Jun 54	Transport Aircraft	Belgian	Yugoslavia	Unknown	Shot at by MiGs but escaped 1 fatality
23 July 54	DC-4	Cathy Pacific	Hainan	Unknown	Shot down by Chinese La-9 fighters 10 fatalities, 8 survived
26 Jul 54	AD-4 x 2	USN	Hainan	Lt Tatham & Ens Crooks Lt's Damien, Rochford, Wahlstrom, Ribble and Lt Cdr Salsig	Attacked by 2 Chinese La-9 fighters two La-9s shot down. Both aircraft victories shared by the various pilots involved
4 Sep 54	P2-V	USN	Siberian Coast	Unknown	Shot down by Soviet MiGs 10 fatalities
12 Sep 54	PB4Y	RoCAF	China	Unknown	Shot Down by PLA AAA near Xiamen - 9 fatalities
7 Nov 54	RB-29	USAF	Sea of Japan nr Hokkaido	Kap Kostin & St Lt Seberyakov	Shot down by Soviet fighters but crash landed 1 fatality and 10 survivors
19 Jan 55	Unknown	US Army	Korea	Unknown	Shot down by ground fire 1 fatality and 1 survivor
5 Feb 55	RB-45C	USAF	Off Korean coast	Unknown	Attacked by 8 MiG-15s escorting F-86s shot down 2 MiGs
17 Apr 54	RB-47	USAF	Kamchatka	Kap Korotkov & Lt Sazhin	Shot down by MiG-17s 3 fatalities
10 May 55	F-86 x 8	USAF	Off Korean coast	Cpt Robert Fulton and 1st Lt Burt Phythyon	Eight F-86s attacked by 12 MiGs 2 MiGs shot down all F-86s undamaged
22 Jun 55	RT-33A	RoCAF	China	Unknown	Shot Down near Fujian by PLA MiG-15 over Jiangxi by PLA MiG-17 - 1 fatality
22 Jun 55	P2-V	USN	Bering Straits	Unknown	Attacked and damaged by 2 MiG fighters aircraft crash landed in Alaska 11 survivors
27 Jul 55	Constellation	EI Al	Bulgaria	Unknown	Attacked and shot down 40 fatalities
18 Aug 55	LT-6	USAF	Korea	Unk	Shot down by ground fire 1 fatality
22 Jun 56	B-17	RoCAF	China	Unknown	Shot Down over Jiangxi by PLA MiG-17 - 11 fatalities
22 Aug 56	P4-M	USN	Wenchow	Z Song	16 fatalities
10 Sep 56	RB-50	USAF	Sea of Japan	Unknown	Disappeared possibly shot down
31 Oct 56	Canberra	RAF	Syria	Unknown	Shot down - 1 fatality

1 Oct 56	Camberra	RoCAF	Syria	Unknown	Shot down - 1 fatality
10 Nov 56	C-46	RoCAF	China	Unknown	Shot Down over Jiejigxi by PLA MiG - 9 fatalities
15 Apr 57	RF-84F	RoCAF	China	Unknown	Crashed whilst being pursued by PLA MiG - 1 fatality
5 Nov 57	B-26	RoCAF	China	Unknown	Shot Down - 5 POWs
23 Dec 57	T-33	USAF	Albania	Unknown	Possibly shot down
18 Feb 58	RB-57A	RoCAF	Yellow Sea	Unknown	Shot down over Shandong by PLAN J-5A - 1 fatality
6 Mar 58	F-86	USAF	N Korea	Unknown	Shot down by ground fire 1 survivor
17 Jun 58	RF-84F	RoCAF	China	Unknown	Crashed in Fujian whilst pursued by PLA MiG15s - 1 fatality
27 Jun 58	C-118	USAF	Soviet Armenia	Kap's Svetlichnikov & Zakharov	Shot down by Soviet MiG-17s all 9 crew survived
2 Sep 58	C-130A	USAF	Soviet Armenia near Yerevan	St Lt's Gavrilov, Ivanov, Kucheryaev & Lopatkov	6 fatalities returned to USA - 11 unaccounted for. Rumours that some crew members died in Soviet prisons
29 Sep 58	C-46	RoCAF	China	Unknown	Shot Down by PLA - 3 fatalities
2 Oct 58	C-46	RoCAF	China	PLA AAA	Shot Down - 5 fatalities
31 Oct 58	RB-47	USAF	Black Sea	Unknown	Attacked by Soviet fighters but survived
7 Nov 58	RB-47	USAF	Baltic Sea	Unknown	Attacked by Soviet fighters but survived
7 Nov 58	RB-47	USAF	Sea of Japan	Unknown	Attacked by Soviet fighters but survived
29 May 59	B-17	RoCAF	China	Unknown	Shot down near Guandong by MiG-17PF - 14 fatalities
16 Jun 59	P2-V	USN	Sea of Japan	Unknown	Attacked by Soviet fighters but survived
7 Oct 59	RB-57D	RoCAF	China	SA-2 missile	Shot down near Beijing - 1 fatality
1 May 60	U-2	CIA	Sverdlovsk	SA-2 missiles	Shot down pilot later returned to USA
25 May 60	C-47	USAF	E Germany	Soviet MiGs	Forced down all 9 crew returned to USA
1 Jul 60	ERB-47H	USAF	Barents Sea	Kap Vasilii Polyakov	Shot down 2 survivors, 4 fatalities
15 Feb 61	P4Y	RoCAF	China	Burmese fighter aircraft	Shot down near Thai-Burma border - 5 fatalities
2 Aug 61	RF-101A	RoCAF	Fukien	Unknown	Shot down by PLA AAA - 1 fatality
6 Nov 61	RB-69A	RoCAF	China	SA-2 missile	Shot down by PLA AAA - 13 fatalities
5 Jun 62	DC-3	Sweden	Baltic	Unknown	Shot down
16 Jun 62	Catalina	Sweden	Baltic	Unknown	Shot down
1 Aug 62	RB-69A	RoCAF	China	Unknown	Believed shot down - 13 fatalities
9 Sep 62	U-2A	RoCAF	China	SA-2 missile	Shot down over Nanchang - 1 fatality
27 Oct 62	U-2C	USAF	Cuba	SA-2 missile	Shot down
17 May 63	Helicopter	US Army	N Korea	Unknown	Shot down 2 survivors
19 Jun 63	RB-69A	RoCAF	China	Unknown	Shot down 14 fatalities
6 Aug 63	LT	USAF	N Korea	Unknown	Shot down
1 Nov 63	U-2C	RoCAF	Shanghai	SA-2 missile over Jiangxi	Shot down
24 Jan 64	T-39	USAF	E Germany	Unknown	3 fatalities
10 Mar 64	RB-66C	USAF	E Germany	Unknown	
11 Jun 64	RB-69A	RoCAF	China	Unknown	Shot down by PLA MiG-17F
7 Jul 64	U-2C	RoCAF	China	Shot down by SA-2 missile over Fujian	1 survivor
18 Dec 64	RF-101A	RoCAF	China	Unknown	Shot down by PLAN J-6
10 Jan 65	U-2C	RoCAF	China	SA-2 missile	1 fatality

5 Jun 62	DC-3	Sweden	Baltic	Unknown	Shot down
16 Jun 62	Catalina	Sweden	Baltic	Unknown	Shot down
1 Aug 62	RB-69A	RoCAF	China	Unknown	Believed shot down - 13 fatalities
9 Sep 62	U-2A	RoCAF	China	SA-2 missile	Shot down over Nanchang - 1 fatality
27 Oct 62	U-2C	USAF	Cuba	SA-2 missile	Shot down
17 May 63	Helicopter	US Army	N Korea	Unknown	Shot down 2 survivors
19 Jun 63	RB-69A	RoCAF	China	Unknown	Shot down 14 fatalities
6 Aug 63	LT	USAF	N Korea	Unknown	Shot down
1 Nov 63	U-2C	RoCAF	Shanghai	SA-2 missile over Jiangxi	Shot down
24 Jan 64	T-39	USAF	E Germany	Unknown	3 fatalities
10 Mar 64	RB-66C	USAF	E Germany	Unknown	
11 Jun 64	RB-69A	RoCAF	China	Unknown	Shot down by PLA MiG-17F
7 Jul 64	U-2C	RoCAF	China	Shot down by SA-2 missile over Fujian	1 survivor
18 Dec 64	RF-101A	RoCAF	China	Unknown	Shot down by PLAN J-6
10 Jan 65	U-2C	RoCAF	China	SA-2 missile	1 fatality
18 Mar 65	RF-101	RoCAF	China	Unknown	Shot down by PLA MiG-19 - 1 fatality
27 Apr 65	ERB-47H	USAF	N Korea	Unknown	Attacked by N Korean MiGs crew survived
31 Aug 65	C-123B	RoCAF	China	Unknown	Believed shot down over South China Sea
27 Jun 65	C-123B	RoCAF	China	Unknown	Shot down by Viet Kong over Saigon
11 Sep 65	RB-57F	Pakistan	India	SA-2 missile	Aircraft damaged but made a crash landing
1 Oct 65	U-2C	RoCAF	China	Unknown	Shot down by PLA SA-2 over Inner Mogolia
14 Dec 65	RB-57F	USAF	Black Sea	SA-2 missile	Shot down- 2 fatalities
10 Jan 66	HU-16A	RoCAF	Formosa	Unknown	Shot down by PLA MiG-17 over Matsu whilst transporting defectors to Taiwan.
22 Aug 67	C-123B	RoCAF	China	Unknown	Believed shot down over South China Sea
8 Sep 67	U-2	RoCAF	China	SA-2 missile	Shot Down
2 Apr 68	U-2C	RoCAF	China	Unknown	Shot down
2 Apr 68	U-2C	RoCAF	China	Unknown	Shot down
30 Jun 68	DC-8	USAF	Kurile Islands	Kap's Igonin, Alexandrov, Moroz & Maj Evtoshenko	Forced down by Soviet fighters all 17 on board survived
Jan 69	U-2C	RoCAF	China	SA-2 missile	Shot down
16 May 69	U-2C	RoCAF	China	SA-2 missile	Shot down
15 Apr 69	EC-121M	US Navy	North Korea	Unknown	Shot down by N Korean MiGs all 31 crew members died
17 Aug 69	OH-23	US Army	Korea	Unknown	Shot down - 3 crew members survived
1970	U-2C	RoCAF	China	SA-2 missile	Shot down
21 Oct 70	U-8	USAF	Armenia	Unknown	Shot down 4 crew survived
14 Jul 77	CH-47	US Army	Korea	Unknown	Shot down 3 fatalities, 1 survivor
20 Apr 78	B-707	Korean Air Lines	Murmansk	Kap A Bosov	Fired on by Soviet SU-15 fighters and crash landed
6 Sep 83	B-747	Korean Air Lines	Sakhalin	Mj's Gennadii & Osipovich	Shot down by Soviet SU-15s all 269 on board were killed
24 Apr 92	C-130	USAF	Peru	Unknown	Attacked by Peruvian Su-22s 1 fatality
17 Dec 94	OH-58A	US Army	Korea	Unknown	Shot down 1 fatality and 1 survivor

Elint - Is There a Better Way?

The U-2



Stanford/Military/Industry Ecosystem

- Stanford did basic research in electronics
- Stanford and SRI do applied research
- Microwave and systems companies in Silicon Valley produce equipment for the military

Terman's Strategy (1)

1. Sit on every possible Military Advisory board
 - Build Network and relationships
2. Reach out to military customers to understand their needs. Then craft a prototype in Stanford's labs
 - *generate revenue for the university and strengthen its military relationship*
3. If the customer liked the prototype, encourage a student to found a company and manufacture at scale
 - *inspired entrepreneurship (and hard work) in the students in the university's labs*

Terman's Strategy (2)

4. Put a Stanford faculty (or Terman) on the board or as a consultant with the new company
 - *This trained Stanford faculty in business and turned them into better teachers and researchers*
5. Provide office space in the Stanford Industrial Park
 - *this ensured that the startup stayed close and helped the entrepreneurial ecosystem reach a higher density*

Consequences For Stanford

1. Stanford became the preferred contractor for ELINT and Electronic Warfare (EW) prototypes
 - Frederick Terman was a ELINT and EW gatekeeper
2. Stanford attracted talented students, military customers, and later, private investor ecosystem
3. Academic research in ELINT and EW was driven by customers' needs rather than being pushed by labd or the agendas of national research agencies
 - Terman as the first advocate for Customer Development

Example: U-2 as an Sigint Platform (1956)

Courtesy of Stanford and Silicon Valley

- System IV
 - 150 - 40,000 MHz
 - Stanford Electronics Laboratories
 - Ramo Woolridge
- E/F Band ELINT recorder (1956)
- A Band ELINT recorder (1959)
- E/F Band Jammer (1959)
 - Granger Associates
- Watkins Johnson
 - QRC -192 Elint receiver
 - 50 -14,000 MHz
- Communications receiver
 - 100-150 MHz/3 channel tape recorder



Example: A-12 ELINT/EWS Suite (1965)

- System VI ELINT analog recorder
 - C, L, X & P Band 50 - 8,000 MHz
- Bluedog SA-2 L-band guidance jammer
- Pinpeg SA-2 warning receiver
 - 2.8-3.2 & 4.8 -5.2 ghz -40 dbm
- Big Blast SA-2 Noise and decep
- Mad Moth SA-2 range gate Jammer

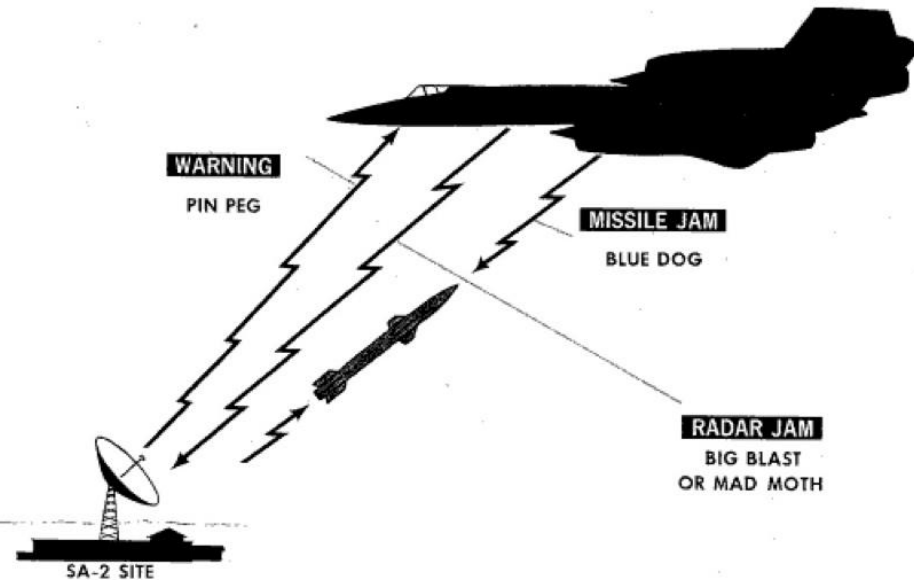

Oxcart Jammers

SYSTEM VI

WIDE BAND CRYSTAL VIDEO ELINT RECEIVER AND RECORDER.

MANUFACTURER - THOMPSON - RAMO - WOOLDRIDGE (TRW SYSTEMS, INC.)

NUMBER OF SYSTEMS IN INVENTORY (3)

WEIGHT - APPROX. 70 LBS.

FREQUENCY COVERAGE - 5 BANDS
50 TO 600 MHz, 600 TO 1GHz

1 GHz TO 2 GHz to 4GHz

4 GHz TO 8 GHz AND TIME CODE GENERATOR

BANDWIDTH - 30 KHz

SENSITIVITY - (-45 dbm)

CAPABILITY - PROVIDES CONTINUOUS ANALOG RECORDING WITHIN THE ABOVE MENTIONED FREQUENCY BANDS.

BLUEDOG

MISSILE GUIDANCE JAMMER - RECEIVES, STORES AND RETRANSMITS SA-2 "L" BAND MISSILE GUIDANCE COMMANDS WHICH PROVIDE FALSE COMMANDS TO THE MISSILE DURING THE TERMINAL PORTION OF THE INTERCEPT.

MANUFACTURER - ELECTRONIC DEFENSE LABS (SYLVANIA)

NUMBER OF SYSTEMS IN INVENTORY (7)

WEIGHT - APPROX. 480 LBS. (INCLUDES CHINE BOX)

CAPABILITY - CAN PROVIDE FALSE COMMANDS TO (27) MISSILE SIMULTANEOUSLY

PEAK POWER OUTPUT - 20,000 WATTS

PIN PEG

THREAT WARNING SYSTEM - DETECTS PRESENCE OF FAN SONG RADAR TRACKING THE AIRCRAFT AND PROVIDES LIGHT INDICATION TO PILOT AND AUTOMATIC JAMMER TURN ON.

MANUFACTURER - WESTINGHOUSE

NUMBER OF SYSTEMS IN INVENTORY - (8)

WEIGHT - APPROX. 30 LBS.

FREQUENCY RANGE - 2.8 GHz to 3.2 GHz
4.8 GHz to 5.2 GHz

DISCRIMINATION - SORTS PRF, SCAN RATE, PULSE WIDTH, FREQUENCY

SENSITIVITY - (-40 dbm)

BIG BLAST

BARRAGE NOISE JAMMER - PROVIDES WIDE BAND NOISE JAMMING TO DENY RANGE INFORMATION TO FAN SONG TRACKING RADAR. THIS SYSTEM IS TURNED ON AUTOMATICALLY BY EITHER PIN PEG OR BLUE DOG.

MANUFACTURER - APPLIED TECHNOLOGY, INC.

NUMBER OF SYSTEMS IN INVENTORY - (6)

WEIGHT - APPROX 400 LBS (INCLUDES CHINE BOX AND PIN PEG)

FREQUENCY RANGE - 2.8 GHz to 3.2 GHz
4.8 GHz. to 5.2 GHz

Microwave Valley - Stanford Spinouts

Military Systems

- Sylvania Electronics Defense Laboratory (1953)
- GE Microwave Laboratory (1956)
- Granger Associates (1956)
- Applied Technology (1959)
- Electronic Systems Laboratories (ESL) (1964)
- Argo Systems (1969)
- Advent Systems (1972)

Microwave Valley - Systems

Some Stanford Alum' s

- Sylvania Electronics Defense Laboratory (1953)
 - Countermeasures, search receivers, converters
 - Hired faculty as consultants, including Terman
- GE Microwave Laboratory (1956)
- Granger Associates (1956) Bill Granger
- Applied Technology (1959) Bill Granger
- Electronic Systems Laboratories (ESL) (1964)
 - William Perry + 6 other' s from Sylvania EDL
- Argo Systems (1969) James de Broekert
- Advent Systems (1972) James de Broekert

Terman Changes the Startup/University Rules

Silicon Valley as We Know it Starts Here

- Graduate students encouraged to start companies
- Professors encouraged to consult for companies
- Terman and other professors take board seats
- Technology transfer/IP licensing easy
- Getting out in the real world was *good* for your academic career
- **Failure was accepted** as part of the culture

Terman Changes the Startup/University Rules

Silicon Valley as We Know it Starts Here

- Graduate students encouraged to start companies
- Professors encouraged to consult for companies
- Terman and other professors take board seats
- Technology transfer/IP licensing easy
- Getting out in the real world was *good* for your academic career

SAMs- Radar Guided Surface-to-Air- Missiles

Protect the Soviet Union From U.S. Bombers

- SA-1 Protect Moscow
 - 1955 IOC
 - 56 sites each w/50 missile
- SA-2 Widely deployed
 - 1957 IOC
 - 1965- 1000 sites each w/6 missiles
- SA-3 Low Altitude coverage
- SA-5 Long Range



Project ASHCAN/GENTRIX – Spy Balloons

- ASHCAN
 - Air sampling output of Soviet Plutonium reactors
 - Brazil, Panama, U.S.
- GENETRIX
 - 516 balloons launched over the Soviet Union
 - 600 lbs of reconnaissance cameras
 - 44 are recovered
- UFO' s?



Stanford and the Cold War

Silicon Valley's 1st Wave

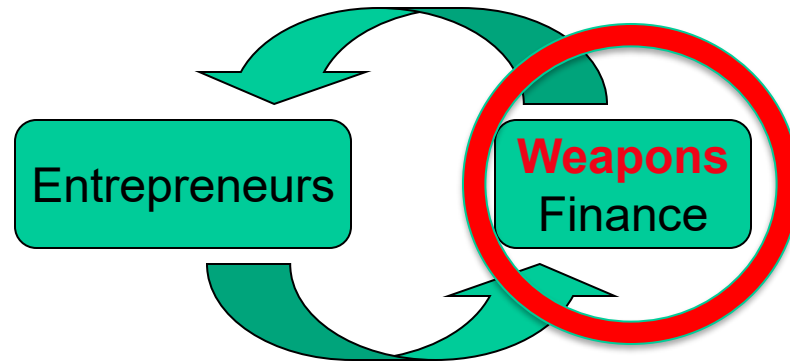

Motivation

Crisis

Profit

Mgmt Tools

Customer Development

Agile
Development

Business Model Design

Design Thinking

Culture

Risk Taking

Entrepreneurial

**Outward-Facing
Tech Universities**

**Free flow of
People/Info**

Infrastructure

**Research
Universities**

Predictable
Economic System

Stable
Legal System

24/7 Utilities

Terman and the Cold War

Silicon Valley's 1st Engine of Entrepreneurship

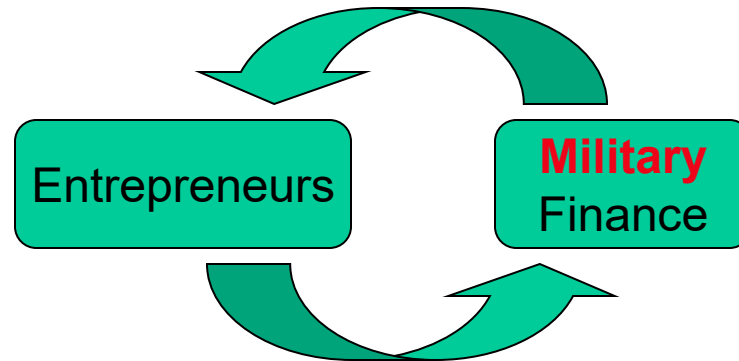

Motivation



Culture

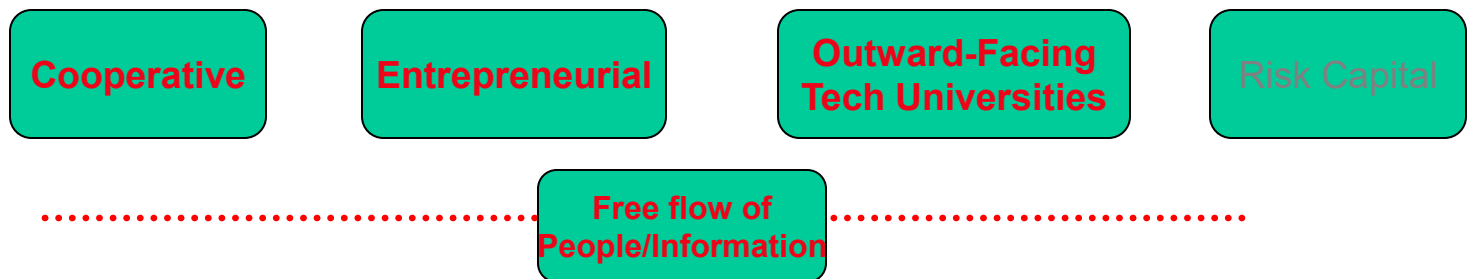

Infrastructure

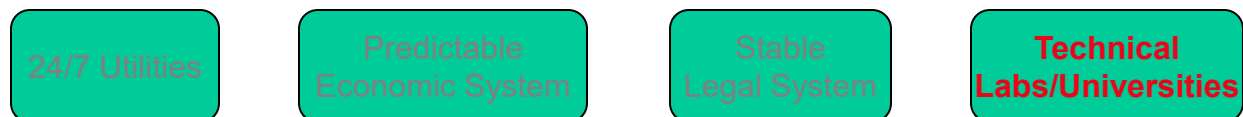

Story 4: Spook Innovation

Project: Melody ~1960

- First noticed in Project Genetrix
 - Soviet P-20 Token radar bounced off our high altitude spy balloons
 - Was received by our radars
 - Hmm...
- Bistatic intercept receiver

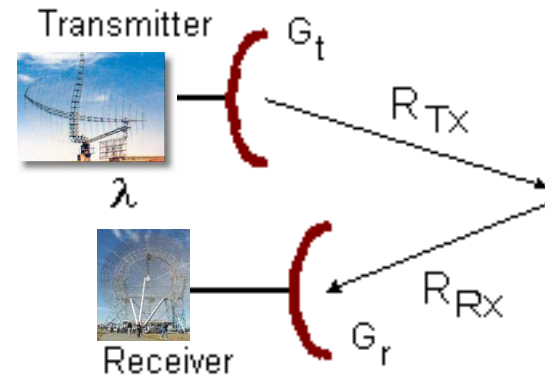

Irony Alert: In WWII Germans used their Klein-Heidelberg Bistatic radar using the British “Chain Home” radar to track allied bombers

Project: Melody ~1960

- Pick up Soviet radars *bounced off their own ICBM's* during test flights
 - Used CIA “Tacksman” intercept sites in Beshahr/Kabkan Iran
 - Use the missiles’ telemetry beacon to steer our radars
- Produced intercepts of all ground-based Soviet missile tracking radars
 - Including all ABM radars
 - At a 1000 mile range
- Later used ionized cloud of Soviets nuclear tests

OXCART / A-12

U-2 Successor



CIA: Directorate of Science & Technology

- Concerned about OXCART* vulnerability
 - First aircraft designed for Stealth (tail was plastic)
 - High speed (Mach 3.3), high altitude (90K feet)
- Facing evolved Soviet air defense system
- ELINT Staff Office (ESO) asked:
 - What's the radar environment like inside the Soviet Union?

* A-12/OXCART was the CIA version of the plane which was kept secret (15 built). SR-71 was the 2 seat Air Force reconnaissance version which was made public (31 built.) The YF-12 was an Air Force fighter interceptor (3 built.)

Problem: Find All the “Tall Kings”

- Primary Soviet Air Defense Radar
 - Long Range, 375 miles
 - 150mhz, PRF 100/200hz, 800Kw
 - 100’ wide, 30’ high
- Where were they located?
- How many are there?
 - B52 bombers needed to know
 - OXCART needed to know



Solution: Project “Flower Garden”

Shoot the Moon

- Point dishes at the moon
- Use the moon as a bistatic reflector
- Listen for TALL KING signals
 - As earth and moon revolved and rotated all TALL KING’ s came into view, one at a time
 - Plot their precise location

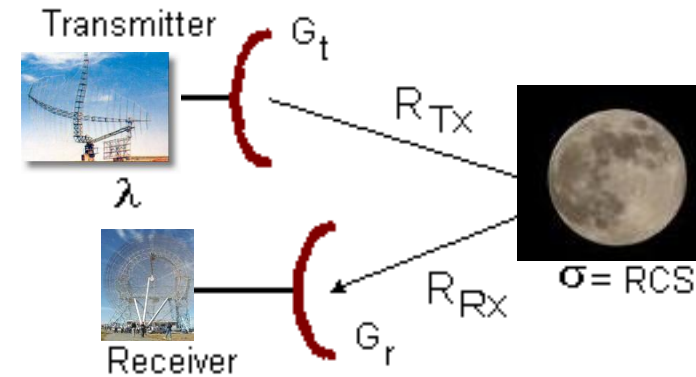

Solution: Project “Flower Garden”

Shoot the Moon

- Point dishes at the moon
- Use the moon as a bistatic reflector
- Listen for TALL KING signals
 - As earth and moon revolved and rotated all TALL KING’ s came into view, one at a time
 - Plot their precise location

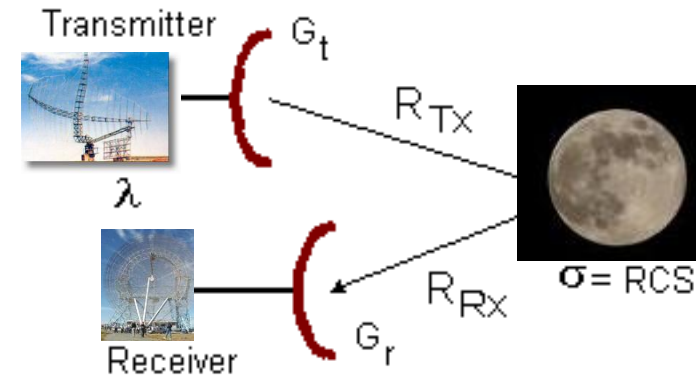

HENHOUSE Radar

- Soviet HENHOUSE phased-array radar
 - 850' long, 25MW
 - Missile Warning/ABM system
 - Space surveillance
- Identified via satellite photos and ELINT
- But what were its capabilities?

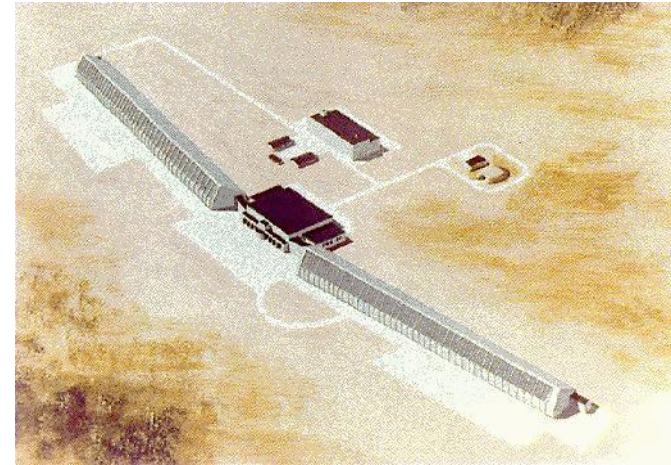

Radio Dishes Get Funded

- Attach ELINT receivers to Bell Labs 60' antenna in New Jersey
- NSA uses antennas at Sugar Grove, Chesapeake Bay, Aricebo, Jordell Bank
- **Pay for and build Stanford "Dish"**
 - Hide relationships via "cover agencies"
 - Discovers "Hen House" radar



Radio Dishes Get Funded

- Attach ELINT receivers to Bell Labs 60' antenna in New Jersey
 - Use Stanford “matched filter” techniques
- Use antennas at Sugar Grove, Chesapeake Bay, Aricebo, Jordell Bank
- Pay for and build Stanford “Dish”
 - Hide relationships via “cover agencies”
 - Air Force Cambridge Research Center and Office of Naval Research
 - Discovers “Hen House” radar



PPMS: Power & Pattern Measurement Systems ~1962

- Now we know where Tall King & Spoon Rest radars are but
- Now we need to know:
 - Spatial Coverage
 - Radiated Power
 - RF Coherence
 - Polarization
- For Jamming and Stealth

Project: Palladium

- Ok, now we know spatial coverage, etc. we need to know:
 - Sensitivity of Soviet radar receivers
 - How good were their operators
- Hence, Project Palladium
- Build a system that electronically generated and injected false targets into Soviet radars
 - They saw ghost aircraft
 - We could simulate any aircraft, any speed
 - Trick was to know what they were seeing

Project: PALLADIUM

- Teamed with NSA and used SIGINT intercepts
 - Listened to their communication channels and could decrypt them *in real time*
 - Watch when they turned on their SA-2 target tracking radar
- We used ground bases, naval ships, submarines

Project Echo 1960

ELINT Balloons in Space

- 100' aluminized mylar balloon
- Cover was “radio relay” tests
- Originally to be launched from Vandenberg
- Launched in Aug 1960
- By this time something else was in space



Story 6:

1956 – Lockheed Comes to Town

We Become Silicon Valley

And Put SIGINT in Space

Story 5: **1956** - The Year It All Changes

Lockheed Comes to Town - 1956

- Polaris missile SLBM
- Built by Lockheed Missiles Division in Sunnyvale
- **20,000 employees by 1960**
 - From 0 in 4 years
 - HP: 3,000 employees 1960



Lockheed Comes to Town

- Polaris missile SLBM
- Built in by Lockheed Missiles Division in Sunnyvale
 - Westinghouse Electric launch tube subcontractor
- *20,000* employees by 1960
 - From 0 in 4 years
 - HP: 3,000 employees 1960



WS-177L Sentry/SAMOS

Move Reconnaissance to *Space*

- Photo – find Soviet ICBMs
- COMINT – listen to communications
- ELINT – find radars
- IR – Missile launch detection via infrared
- Nuclear – detect nuclear explosions
- Weather – pre and post strike assessment



The 1958 Swiss Army Knife of Reconnaissance

WS-177L - Space Reconnaissance – 1950's

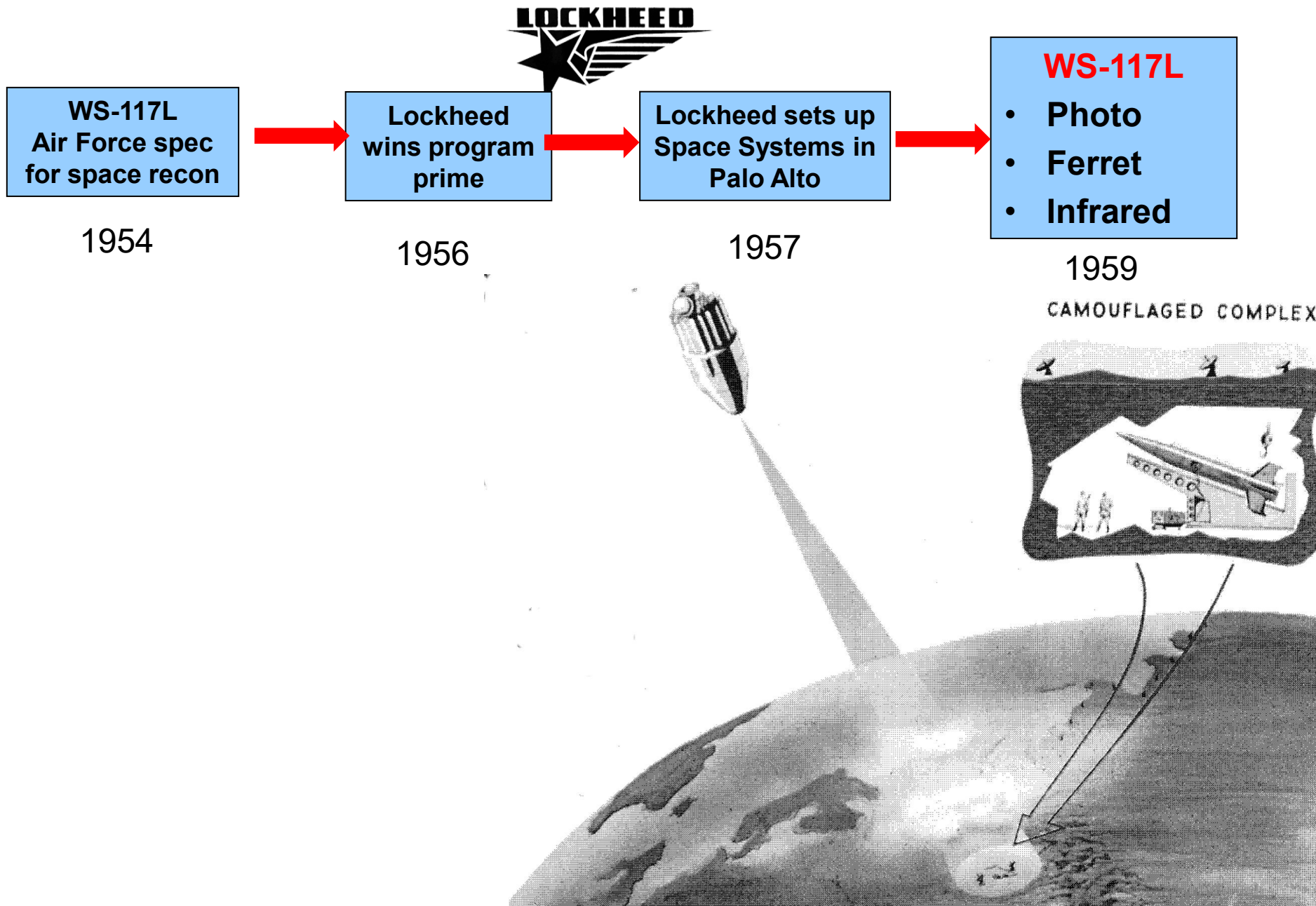

WS-117L Sentry – Recon Systems

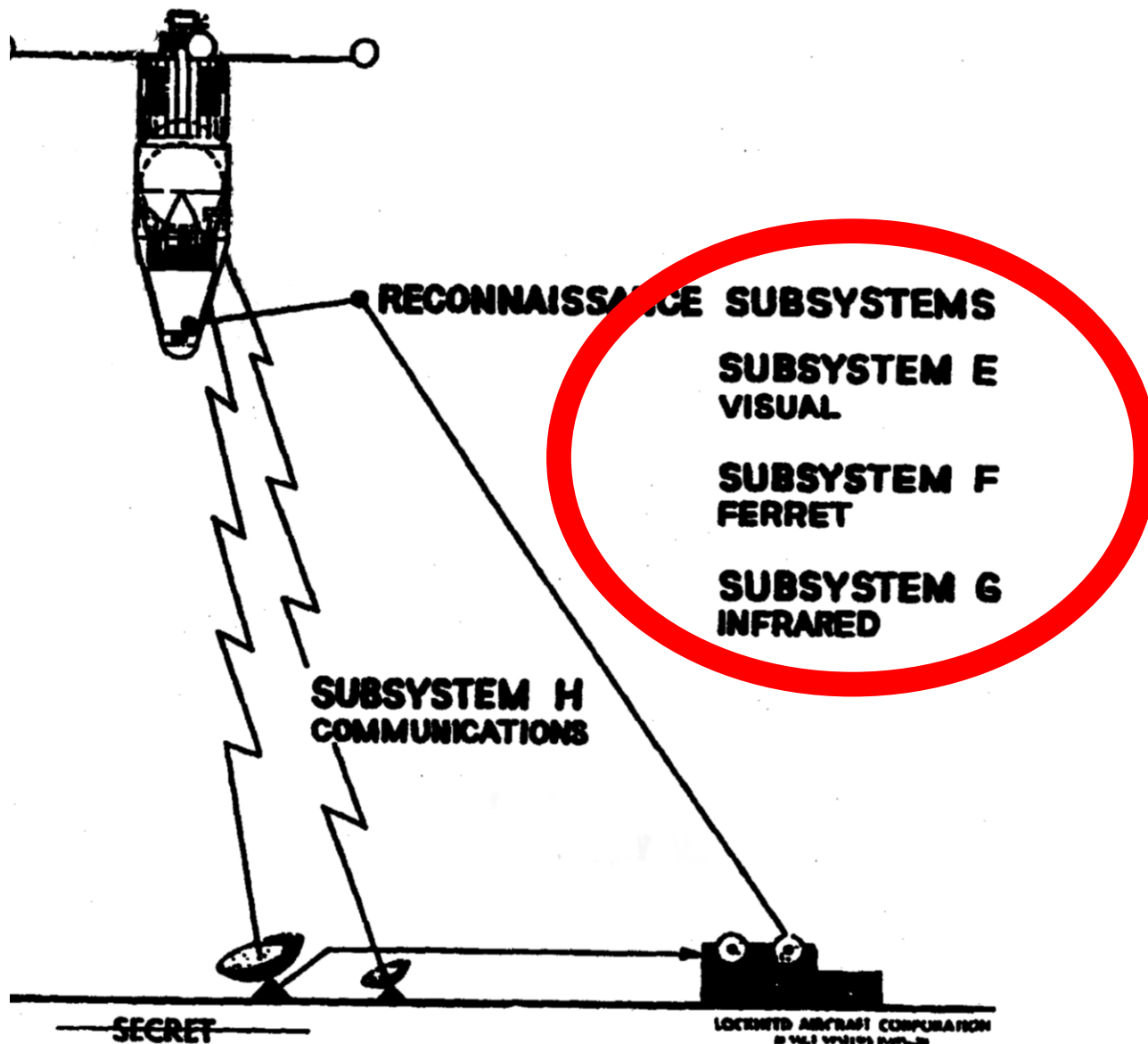

SENTRY OPERATIONAL OBJECTIVES

VISUAL RECONNAISSANCE

- MAPPING OF USSR AND SATELLITES

- * STRATEGIC WARNING INDICATIONS

- WEAPONS AND BASES IN BEING
- MILITARY LOGISTICS
- INDUSTRIAL WAR CAPABILITIES

* OPEN SKY NATIONAL OBJECTIVES

- NUCLEAR DETONATION DETECTION

- WEATHER OBSERVATION

ELECTRONIC RECONNAISSANCE

- * DETECT & OBTAIN INFORMATION ON ELECTRONIC EMITTERS IN AREAS OF USSR & SATELLITES NOT NOW AVAILABLE

INFRARED RECONNAISSANCE

- * ICBM ATTACK WARNING

COMMUNICATIONS

- * SATELLITE LINKS FOR SECURE & RAPID GLOBAL COMMUNICATIONS

SECRET

THE SENTRY SUBSYSTEMS

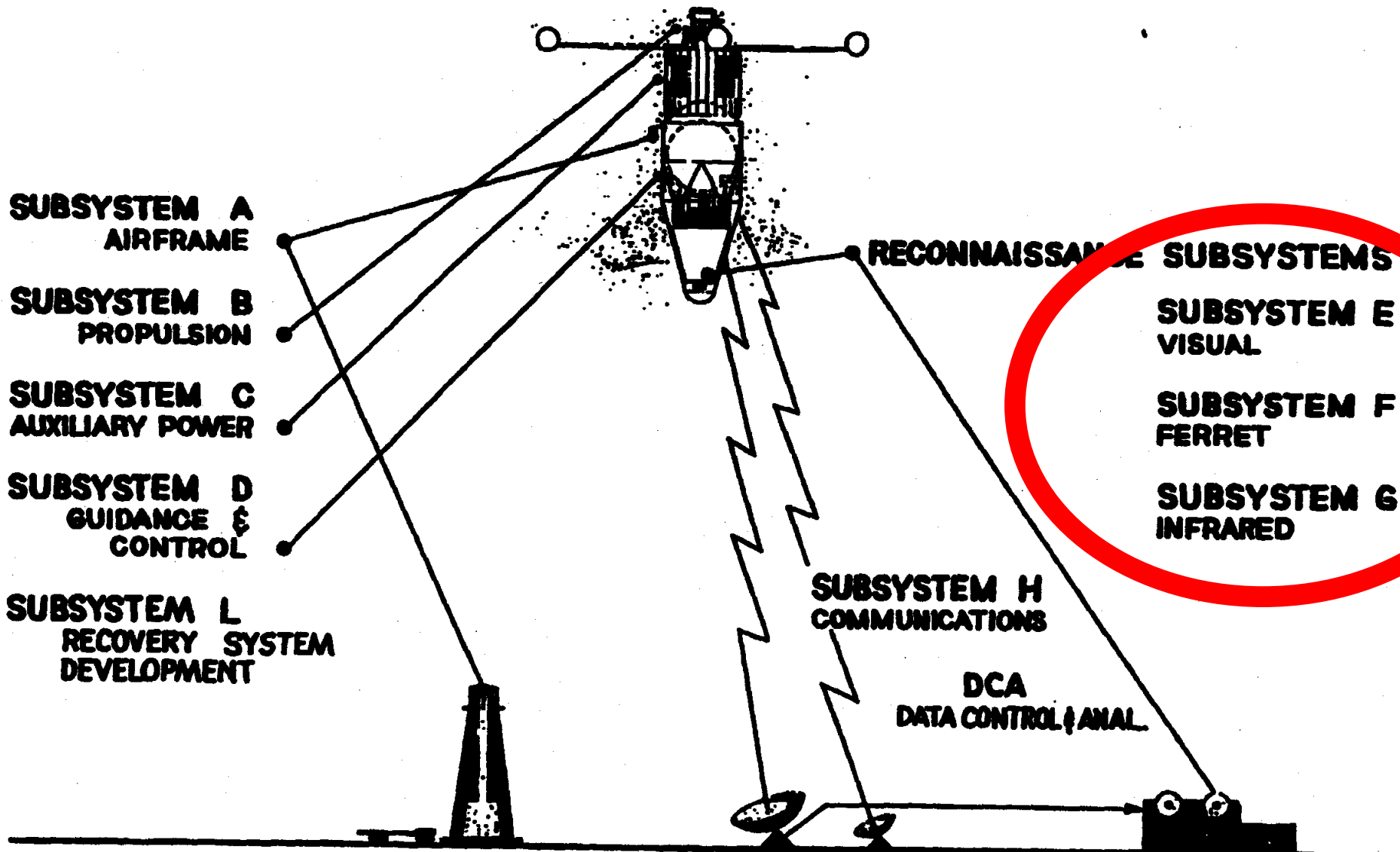

VISUAL RECONNAISSANCE MODEL

LINE GIMBAL LIMITS 6°

ARE PATTERN

WING-BELL AIRCRAFT

HRUST 15,000 LB ALT

JP 263 SEC.

N₂LE EXPANSION RATIO 15:1

N₂ GAS STORAGE FLASK
3000 PSI



ATTITUDE ROLL AND
REORIENTATION CONTROL
GAS JETS (6)

AUXILIARY POWER
SOURCE (BATTERIES)

FUEL TANK
JP-4 60 PSI

OXIDIZER
TANK (IRFNA)
60 PSI

HE GAS STORAGE FLASK (2)
PROPELLANT TANK
PRESSURIZATION 3000 PSI

AL RECONNAISSANCE SYSTEM
ERA PACKAGE (EKC)
O₂ PROCESS, STORAGE,
TRONIC READOUT

MERA LENS SHIELD

SUBSYSTEM ELECTRONICS COMPARTMENT
AND CAMERA SUPPORT STRUCTURE
(GUIDANCE, CONTROL, ETC.)

SE (JETTISONS)

REMOVABLE NOSE FAIRING

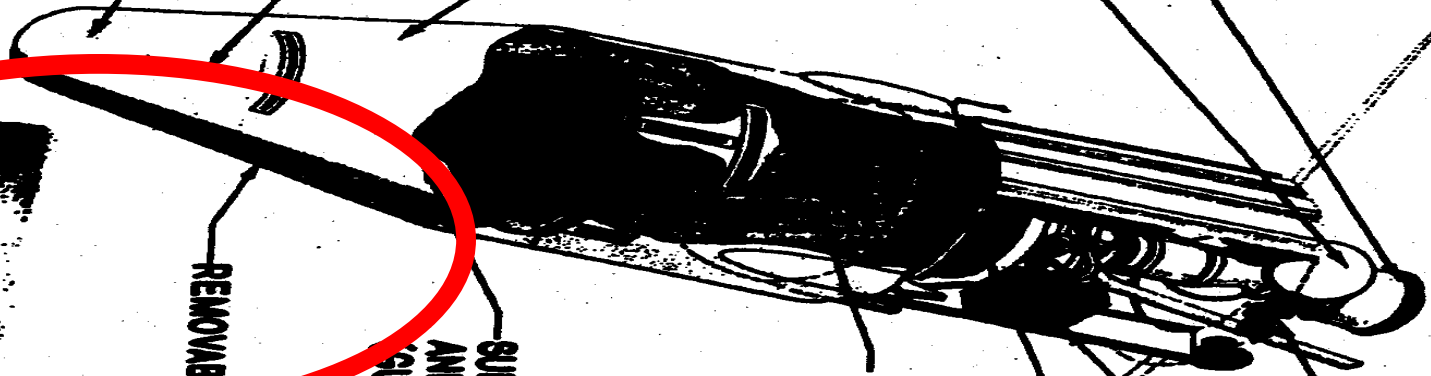

12155A 5/20/69
00776

LM5D 100296

SAMOS FERRET AIRBORNE RECEPTION

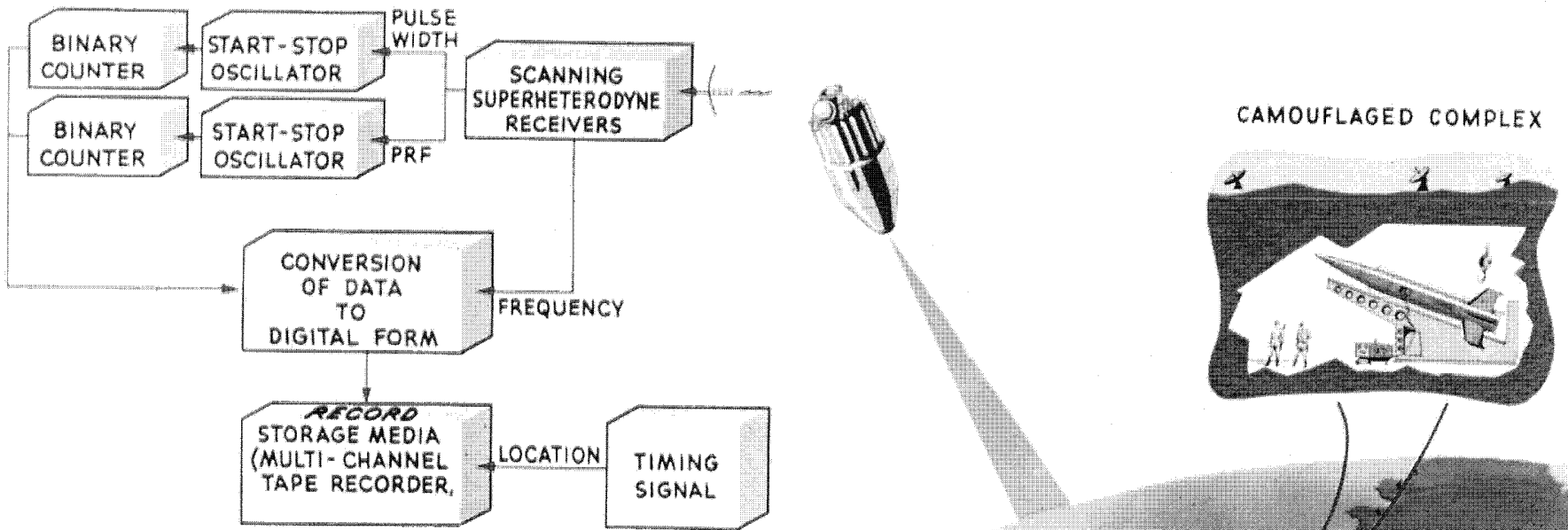

PRIORITY BANDS

1. 2,500 - 3,200 MC/SEC
2. 9,000 - 10,000 MC/SEC
3. (a) 59 - 100 MC/SEC
- (b) 100 - 200 MC/SEC
- (c) 200 - 400 MC/SEC
- (d) 400 - 650 MC/SEC

MONITORING OF ALL BANDS IN THE
50-18,000 MC/SEC SPECTRUM

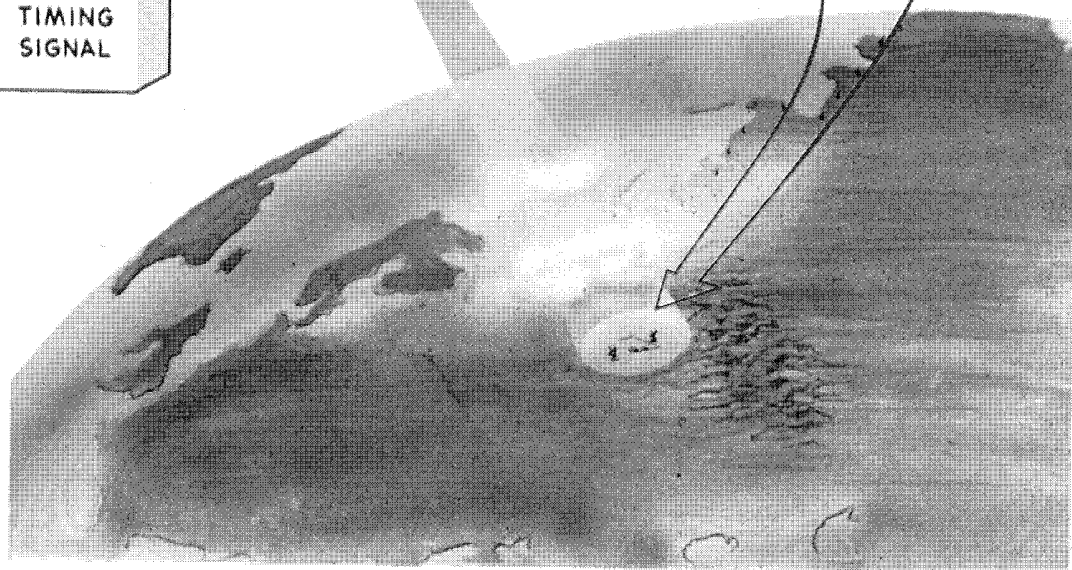

SENTRY FERRET AIRBORNE READOUT

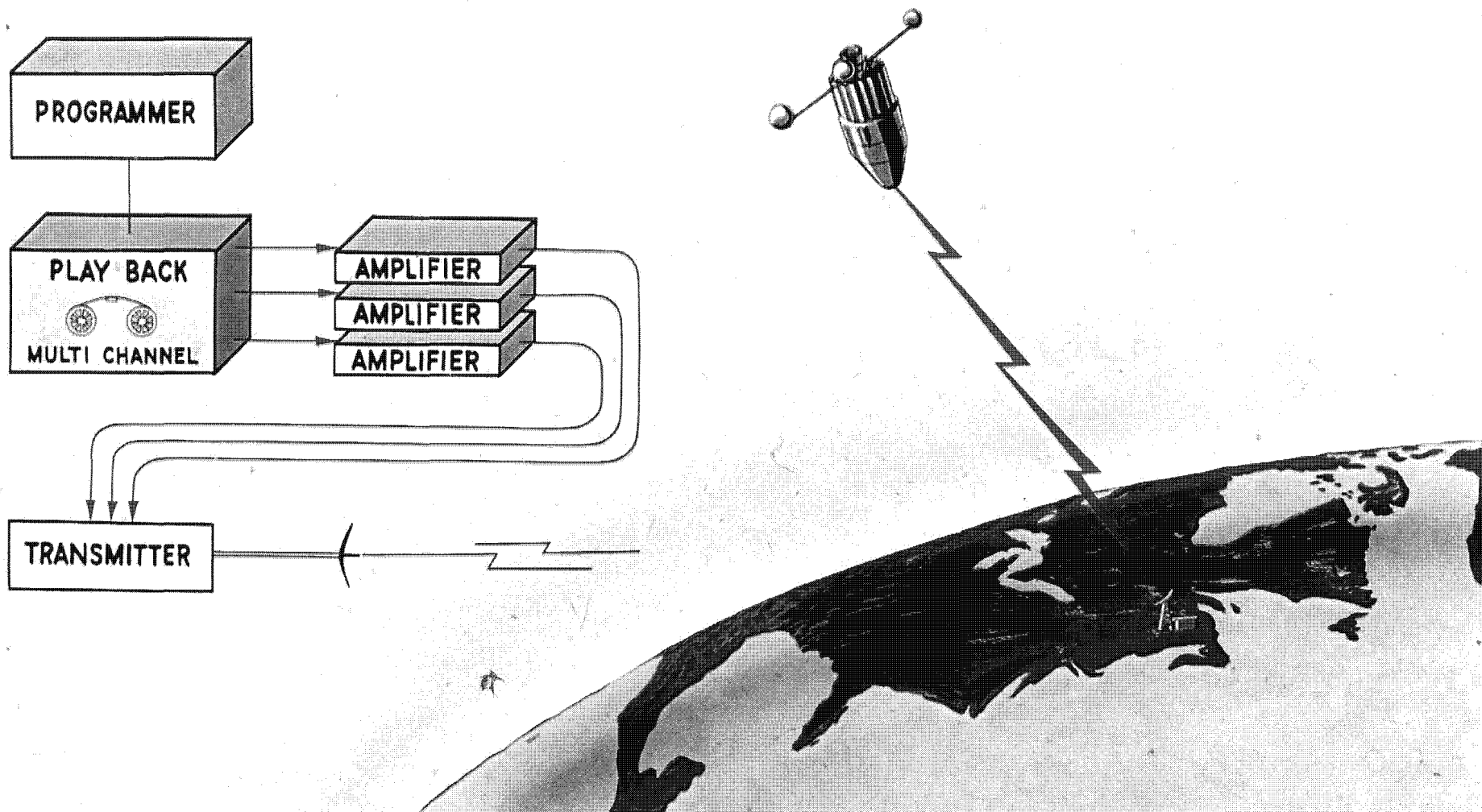

P179(2)SS'F' 2/15/59
WD-59 00852

LM5D/425128 COPY # 7

SECRET

THIS DOCUMENT CONTAINS INFORMATION AFFECTING THE NATIONAL DEFENSE OF THE UNITED STATES WITHIN THE MEANING OF THE ESPIONAGE LAWS, TITLE 18 U.S.C., SECTIONS 793 & 794. ITS TRANSMISSION OR THE REVELATION OF ITS CONTENTS IN ANY MANNER TO AN UNAUTHORIZED PERSON IS PROHIBITED BY LAW.

LOCKHEED AIRCRAFT CORPORATION
MISSILE SYSTEMS DIVISION

WSIITL R&D ORGANIZATION

LOCKHEED AIRCRAFT CORP. MISSILE SYSTEMS DIVISION WEAPON SYSTEM CONTRACTOR

RESEARCH & ANALYSIS
ANTENNA DEVELOPMENT
TELEMETRY

AIRFRAME FABRICATION
CHECKOUT & ASSEMBLY
STATIC & FLIGHT TESTS

PRINCIPAL SUBCONTRACTORS

PROPULSION

- BELL AIRCRAFT CORP.
- AEROJET-GENERAL CORP.

AUXILIARY POWER

- SONOTONE CORP.
- EAGLE-PICHER CO.
- ENGINEERED MAGNETICS
- HOFFMAN ELECTRONICS CORP.
- BEECHCRAFT R&D INC.

GUIDANCE & CONTROL

- DETROIT CONTROLS CORP.
- REEVES INSTRUMENT CORP.
- MINNEAPOLIS-HONEYWELL REGULATOR CO.
- BENDIX AVIATION CORP.

VISUAL RECONN.

- EASTMAN KODAK CO.
- COLUMBIA BROADCASTING SYS.
- SPICA INC.
- AMPEX CORP.

FERRET

- AIRBORNE INSTRUMENTS LAB. INC.
- HALLER, RAYMOND & BROWN INC.

INFRARED RECONN.

- EASTMAN KODAK CO.
- BAIRD ATOMIC CO.
- AEROJET-GENERAL CORP.
- GENERAL MILLS INC.

GROUND-SPACE COMM.

- PHILCO CORP.
- REEVES INSTRUMENT CORP.
- RADIATION INC.
- LOCKHEED AIRCRAFT SERVICES INC.
- HUGHES AIRCRAFT CO.
- TEXAS INSTRUMENT CORP.

TEST MGMT & OPERATIONS

- AEROJET-GENERAL CORP.
- RALPH M. PARSONS CO.

GROUND SUPPORT EQUIP.

- OTIS ELEVATOR CO.
- CONSOLIDATED AVIONICS CORP.
- BEMCO, INC.
- STANDARD MFG. CO. INC.
- HUFFORD CORP.

BIO MEDICAL CAPSULE

- GENERAL ELECTRIC CO.
- ALL AMERICAN ENGINEERING CO.

ASSOCIATE CONTRACTORS

BOOSTERS

- DOUGLAS A/C CORP. (SM-75)
- CONVAIR ASTRONAUTICS (SM-65)

GUIDANCE & CONTROL

- INSTRUMENTATION LAB., MIT
- GENERAL ELECTRIC CO.

AUXILIARY POWER

- THE MARTIN CO.
- ATOMICS INTERNATIONAL

DATA PROCESSING

- RAMO-WOOLDRIDGE CORP.

SIGINT in Space

The Navy Goes First



Project Canes/Grab/DYNO 1960-1962

SIGINT in Space

- No more overflights or balloons
- Collect radar emissions from Soviet air defense radars
 - Record, Store and Dump
 - Built by the Naval Research Laboratory
- Used by SAC for EOB then given to the NRO
- Cover was an unclassified payload: Transit/SolRad

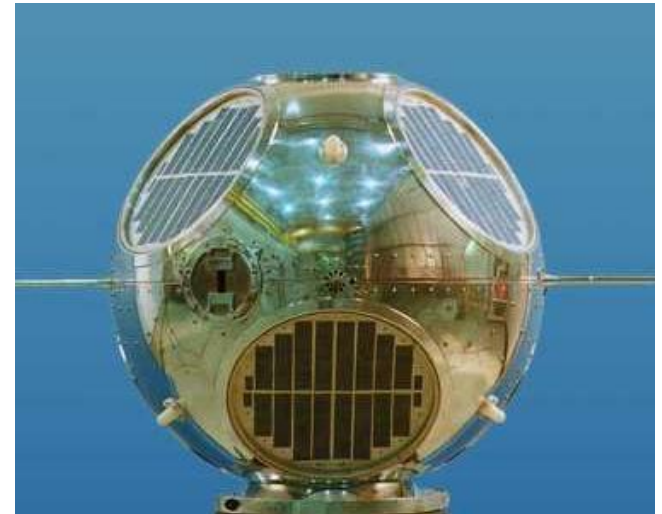

Project Grab 1960-1962

Navy *SIGINT* in Space

- No more overflights or balloons
- Collect radar emissions from Soviet air defense radars
- Used by the Strategic Air Command
- Cover was an unclassified payload: Transit

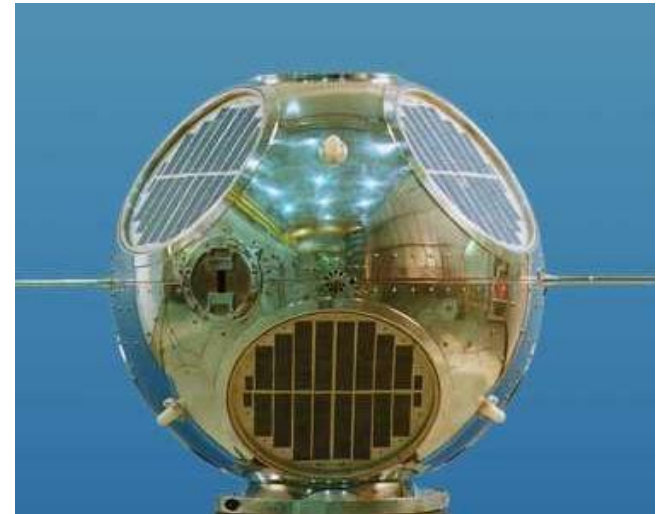

Project POPPY 1962-1971

More *Navy* SIGINT in Space

- Started as ELINT general search
- Expanded to ABM search, telemetry, then Ocean Surveillance
 - Ships can no longer hide
 - Collect radar emissions from Soviet naval vessels
- Two, then three, then four satellites

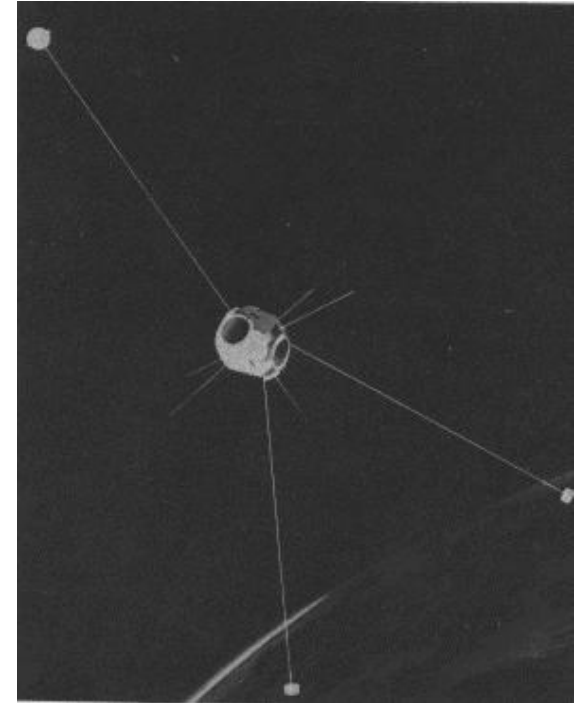

Project POPPY 1962-1971

Navy SIGINT in Space

- Started as ELINT general search
- Expanded to ABM search, telemetry, then Ocean Surveillance
 - Ships can no longer hide
 - Collect radar emissions from Soviet naval vessels
- Two-ball in 1962 then triplet system in 1963 and then four.

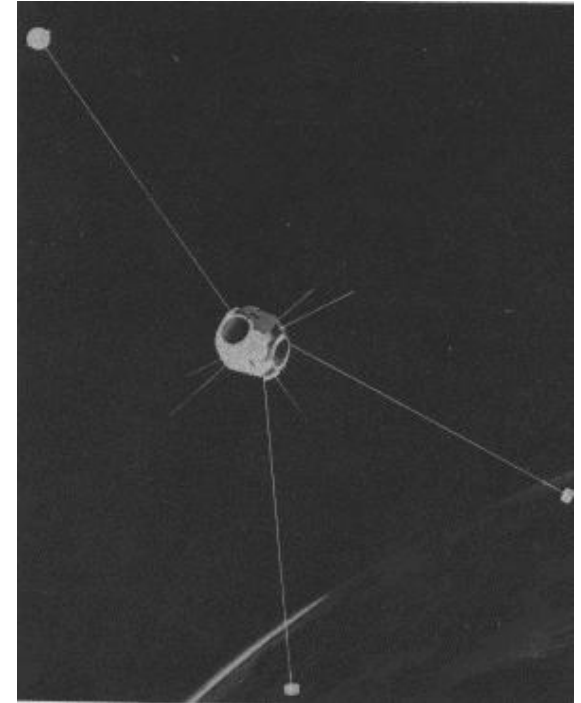

Project POPPY 1962-1971

Navy SIGINT in Space

POPPY operational concept

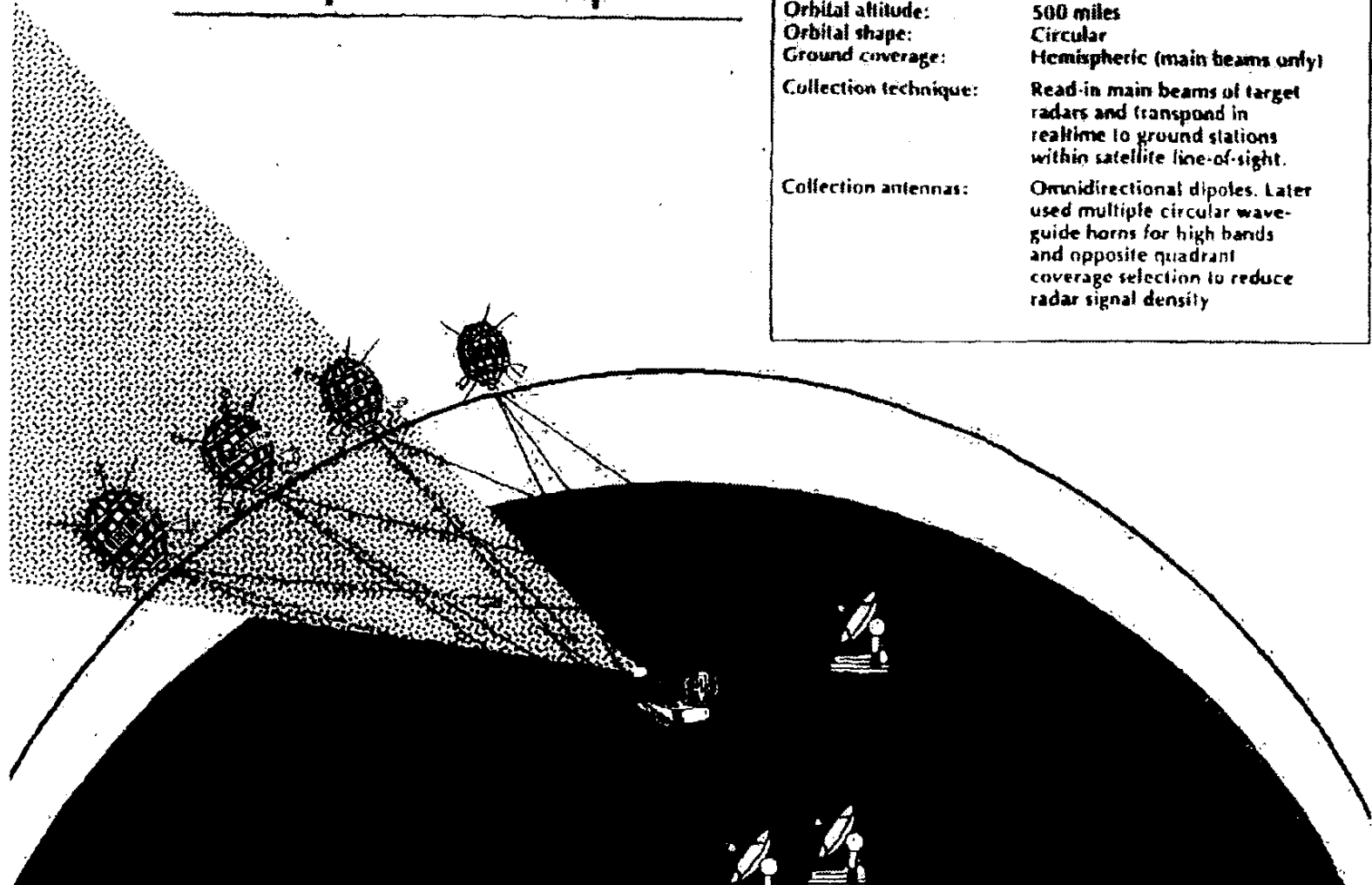

Project POPPY

Orbital inclination:	66° - 78°
Orbital altitude:	500 miles
Orbital shape:	Circular
Ground coverage:	Hemispheric (main beams only)
Collection technique:	Read-in main beams of target radars and transpond in realtime to ground stations within satellite line-of-sight.
Collection antennas:	Omnidirectional dipoles. Later used multiple circular waveguide horns for high bands and opposite quadrant coverage selection to reduce radar signal density

The CIA Goes To Space

CORONA

Photo Reconnaissance from Space



CENTRAL
INTELLIGENCE
AGENCY

Corona – CIAs Better Idea

Film Satellites

- WS-117/Samos/Sentry photo system used on-orbit film developing and electronic read-out
- *Problem:* Downlink data rates too slow for photos
 - Coverage would be 62 frames/day = 16,470 square miles/day
- *Solution:* Build satellites that returned the film to earth
 - Coverage would be 1.5 million square miles/day
 - Catch the capsule in the air!



Corona – CIAs Better Idea

Film Satellites

- WS-117 used on-orbit film developing and fax'd the photos
- *Problem:* Downlink was too slow
 - Coverage would be 62 frames/day = 16,470 square miles/day
- *Solution:* Build satellites that returned the film to earth
 - Coverage would be 1.5 million square miles/day
 - Catch the capsule in the air!



Corona – Covert Program

Film Satellites

- Lockheed prime contractor
- Publically cancelled WS-177L imaging program
- Secretly started Corona film-return program
- ~150 satellites built at Hiller Aircraft in East Palo Alto



Drop Off the Film From Space

Catch the parachute with a plane!

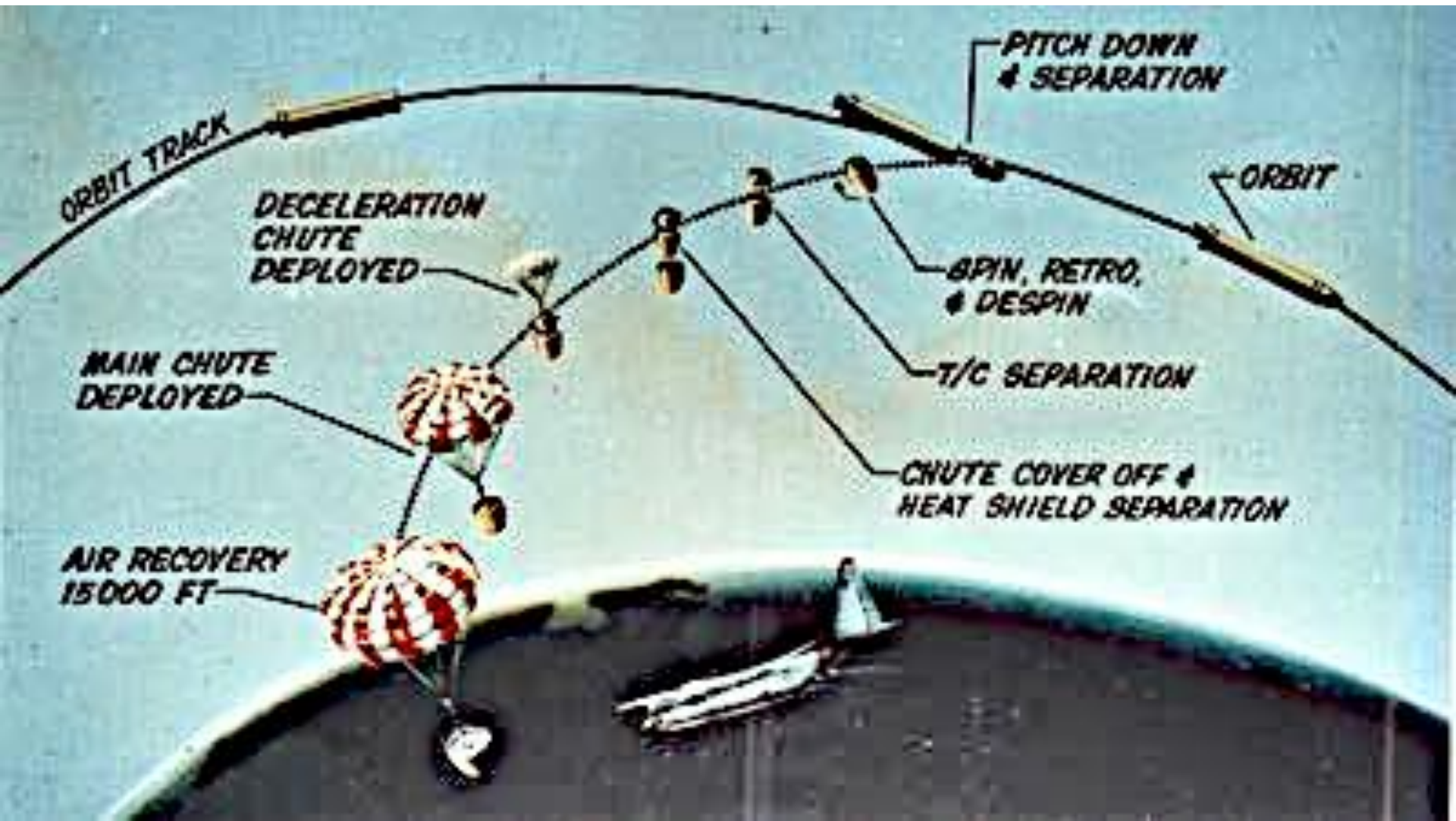

Corona – Covert Program

Film Satellites

- Lockheed prime contractor
- Publically cancelled WS-177L imaging program
- Secretly started Corona film-return program
- ~150 built at Hiller Aircraft in East Palo Alto



Lockheed: Corona *First Photo Satellites* – built in Hiller Aircraft in East Palo Alto 1958-1969

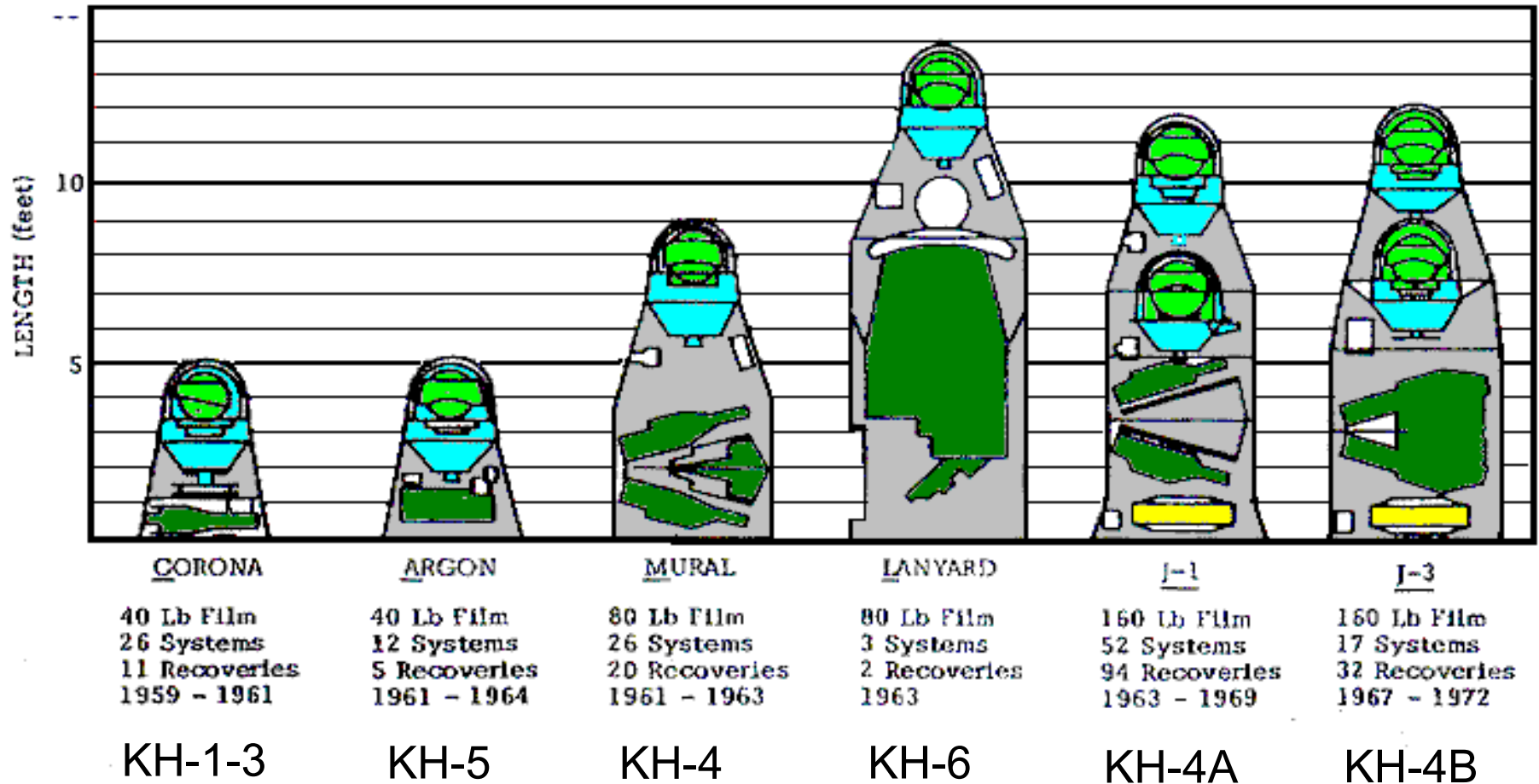

Corona Cameras

KH-1

KH-2

KH-3

KH-5

KH-4A

KH-4B

~~SECRET~~
NOFORN-ORCON

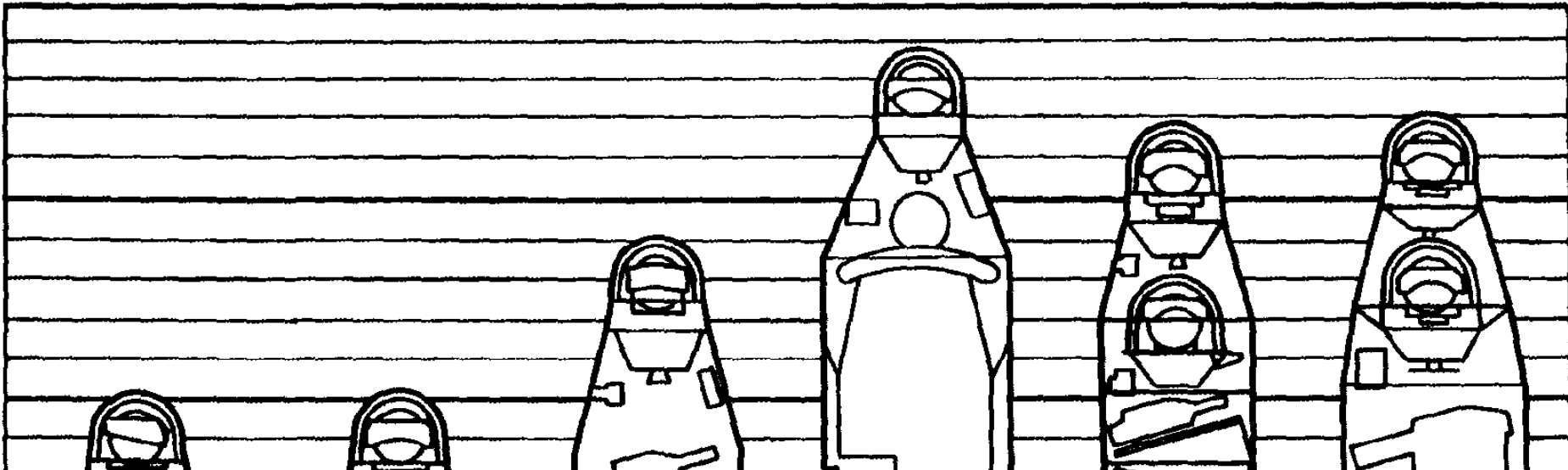

Corona KH-4B J-3 Camera

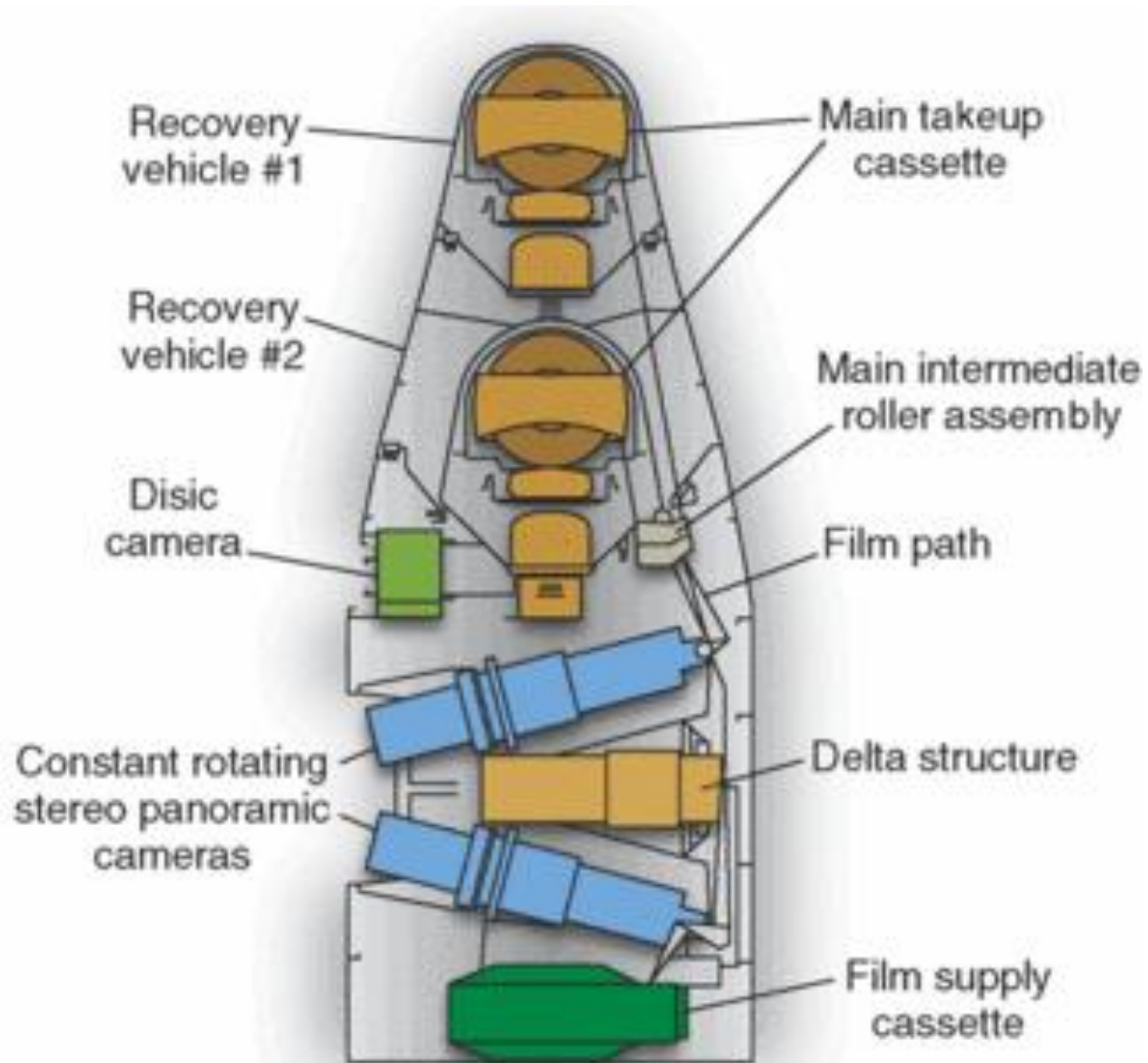

Gambit KH-7 and Hexagon KH-8

Photo Reconnaissance from Space

Gambit

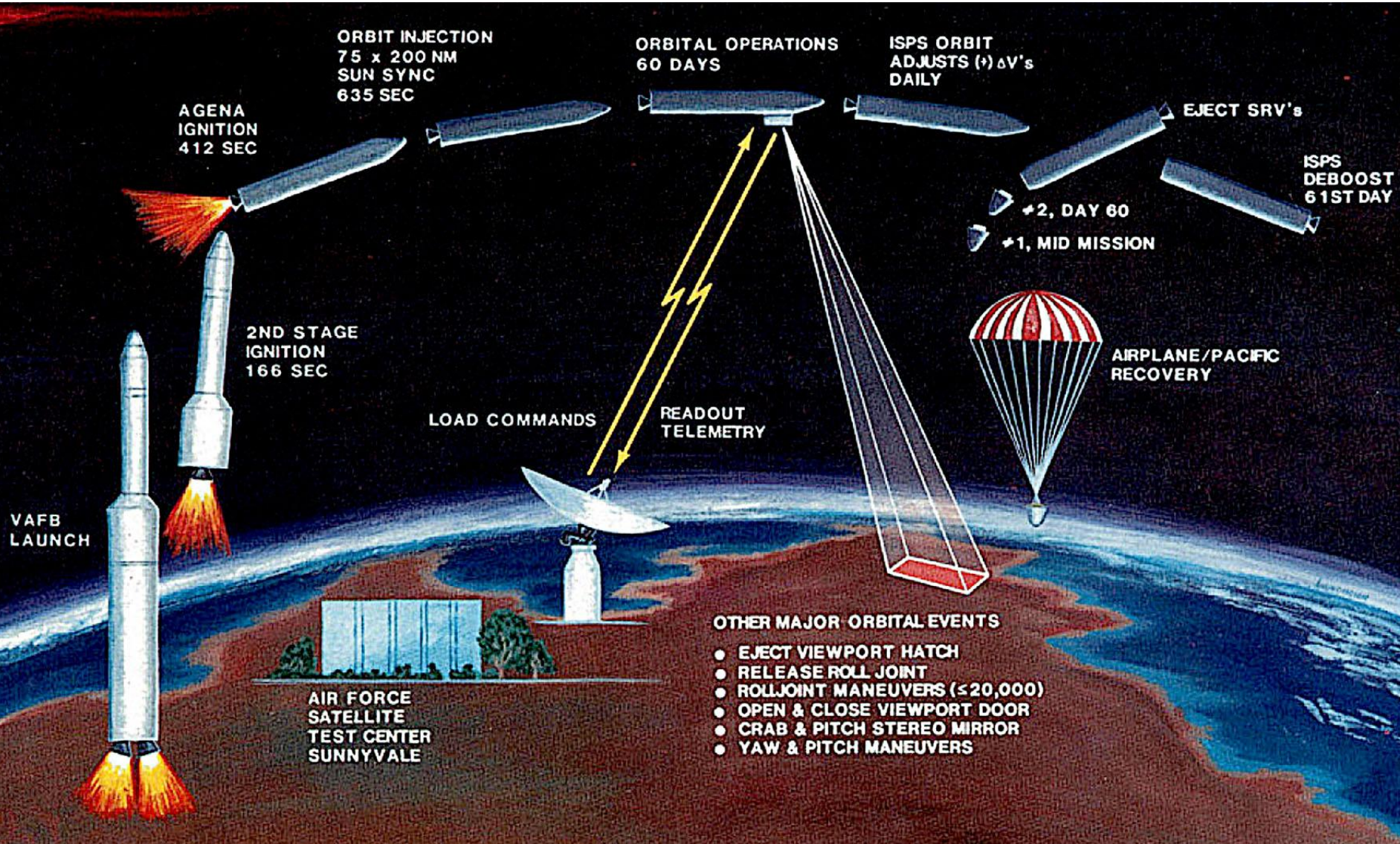

Gambit – KH-7

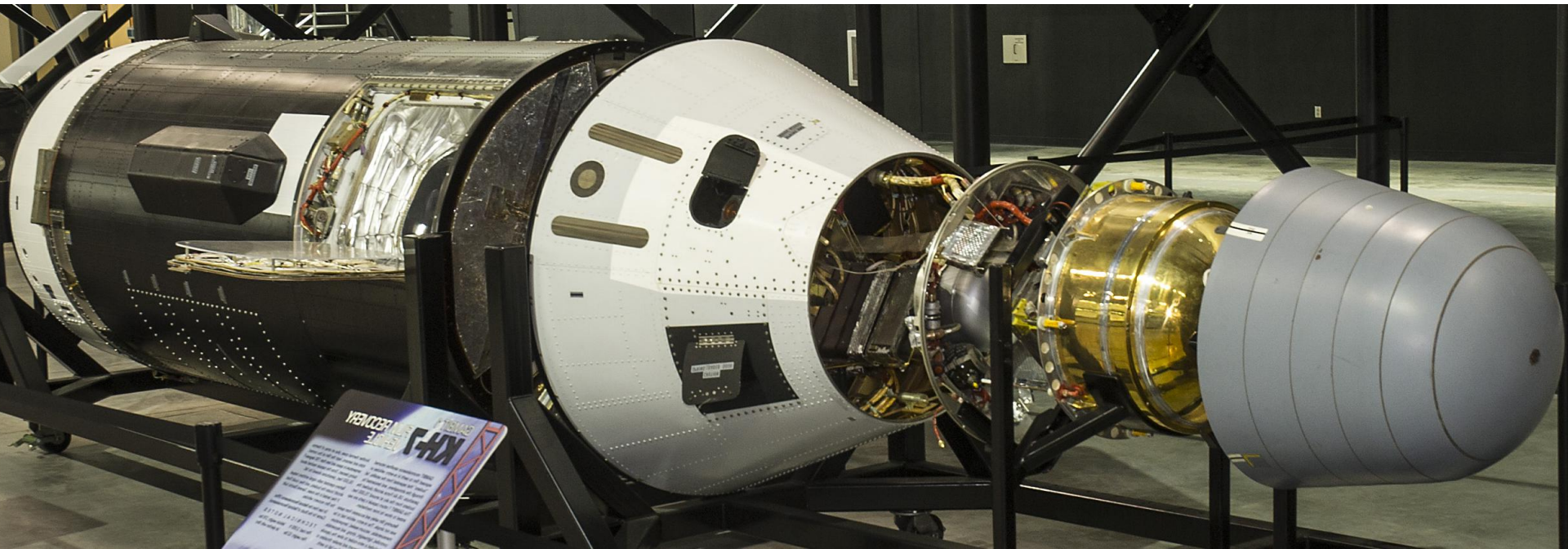

Lockheed

Gambit KH-8 and Hexagon KH-9

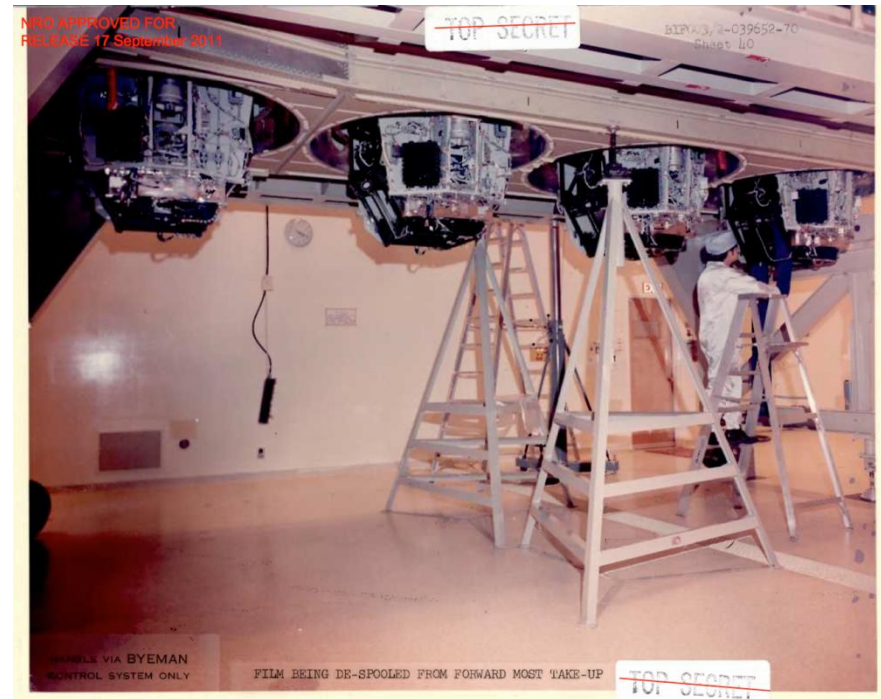
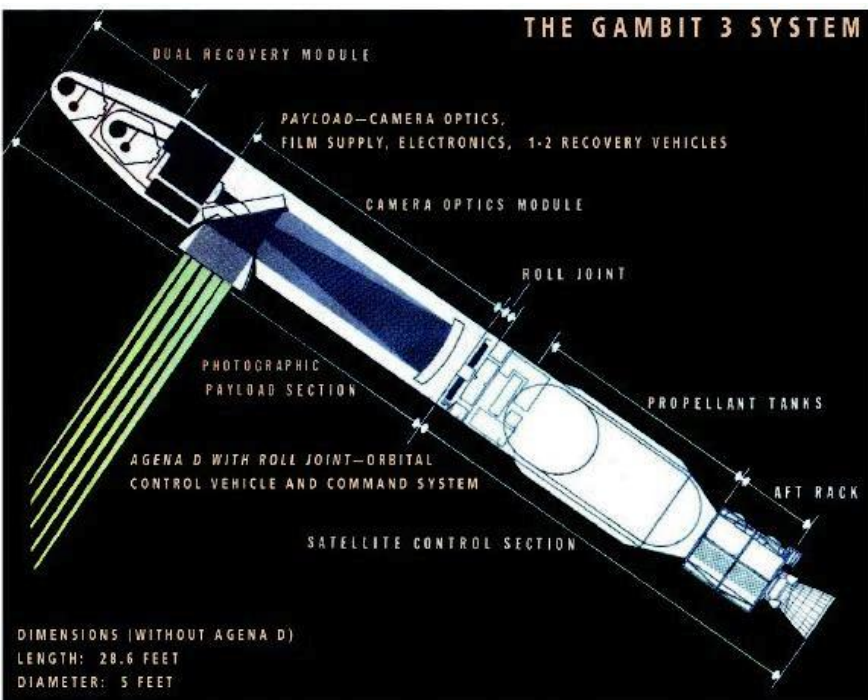

Lockheed: Hexagon

Photo Satellites the Size of School Bus

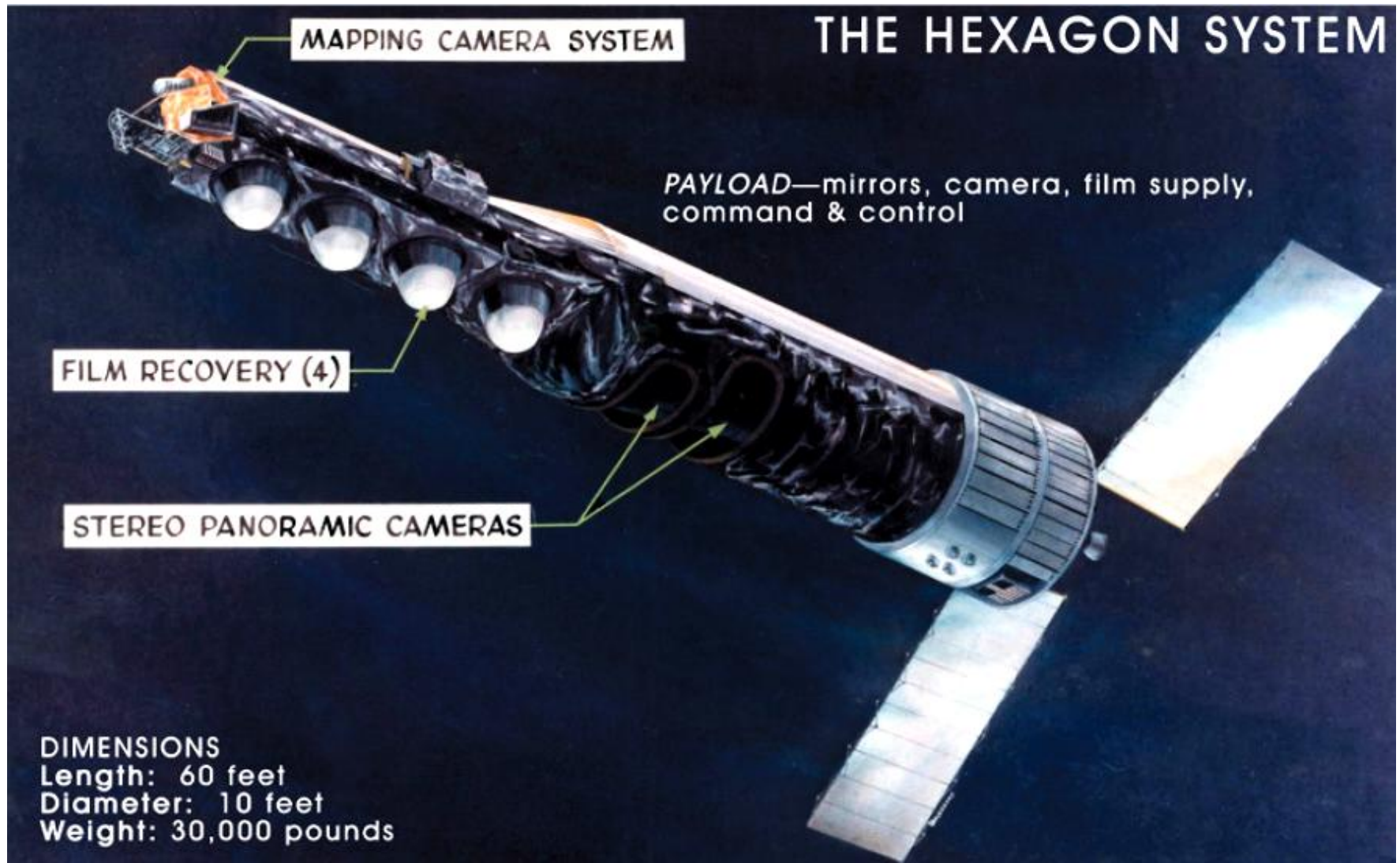

Hexagon

2 PAN CAMERAS

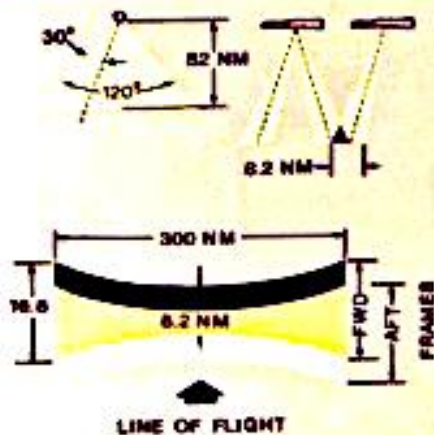

MAPPING FRAME CAMERA

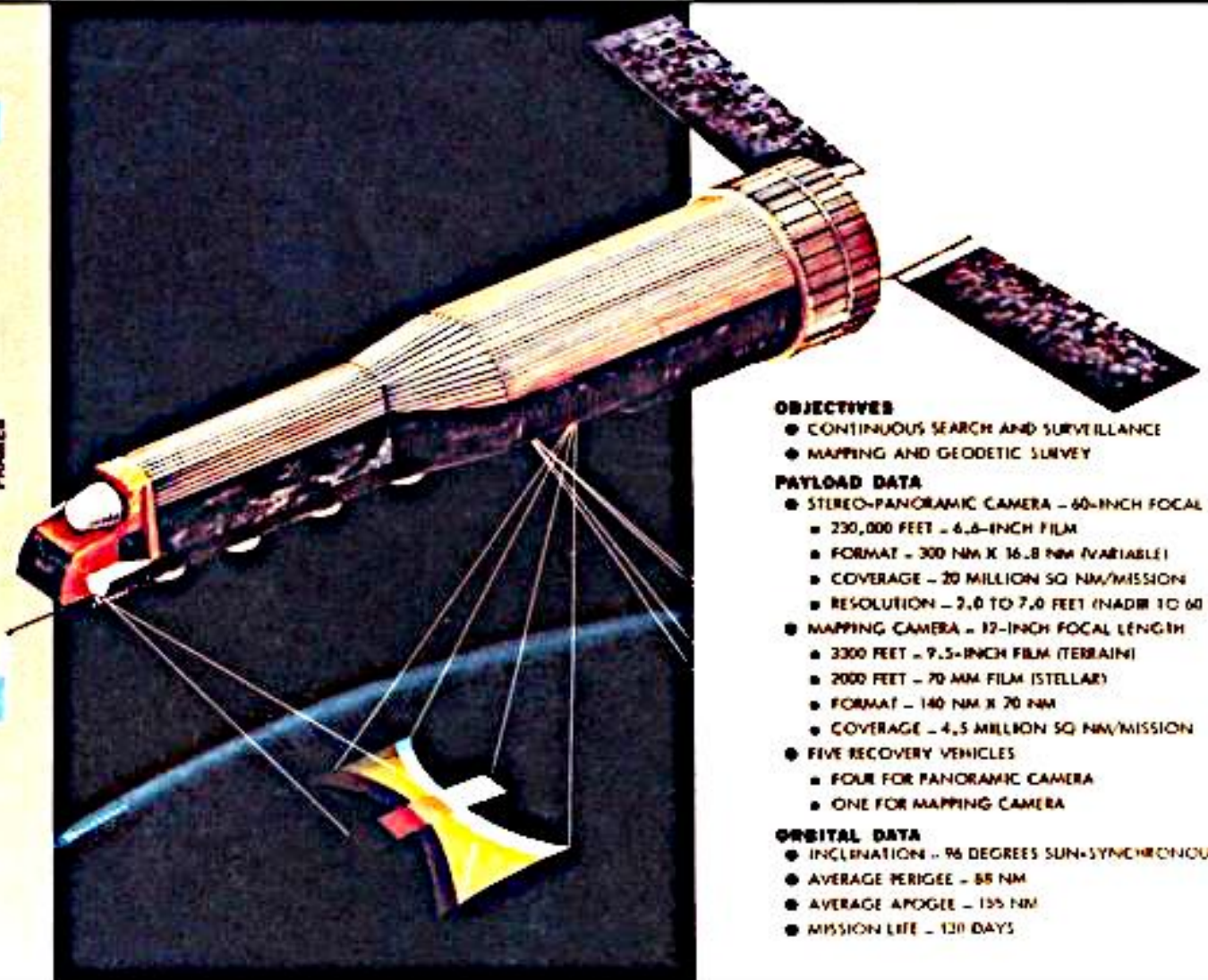

OBJECTIVES

- CONTINUOUS SEARCH AND SURVEILLANCE
- MAPPING AND GEODETIC SURVEY

PAYLOAD DATA

- STEREO-PANORAMIC CAMERA - 60-INCH FOCAL LENGTH
 - 230,000 FEET - 4.8-INCH FILM
 - FORMAT - 300 NM X 36.8 NM (VARIABLE)
 - COVERAGE - 20 MILLION SQ NM/MISSION
 - RESOLUTION - 2.0 TO 7.0 FEET (NADIR TO 60 DEGREE)
- MAPPING CAMERA - 37-INCH FOCAL LENGTH
 - 3300 FEET - 9.5-INCH FILM (TERRAIN)
 - 2000 FEET - 70 MM FILM (STELLAR)
 - FORMAT - 140 NM X 70 NM
 - COVERAGE - 4.5 MILLION SQ NM/MISSION
- FIVE RECOVERY VEHICLES
 - FOUR FOR PANORAMIC CAMERA
 - ONE FOR MAPPING CAMERA

ORBITAL DATA

- INCLINATION - 96 DEGREES SUN-SYNCHRONOUS
- AVERAGE PERIGEE - 85 NM
- AVERAGE APOGEE - 135 NM
- MISSION LIFE - 120 DAYS

Hexagon

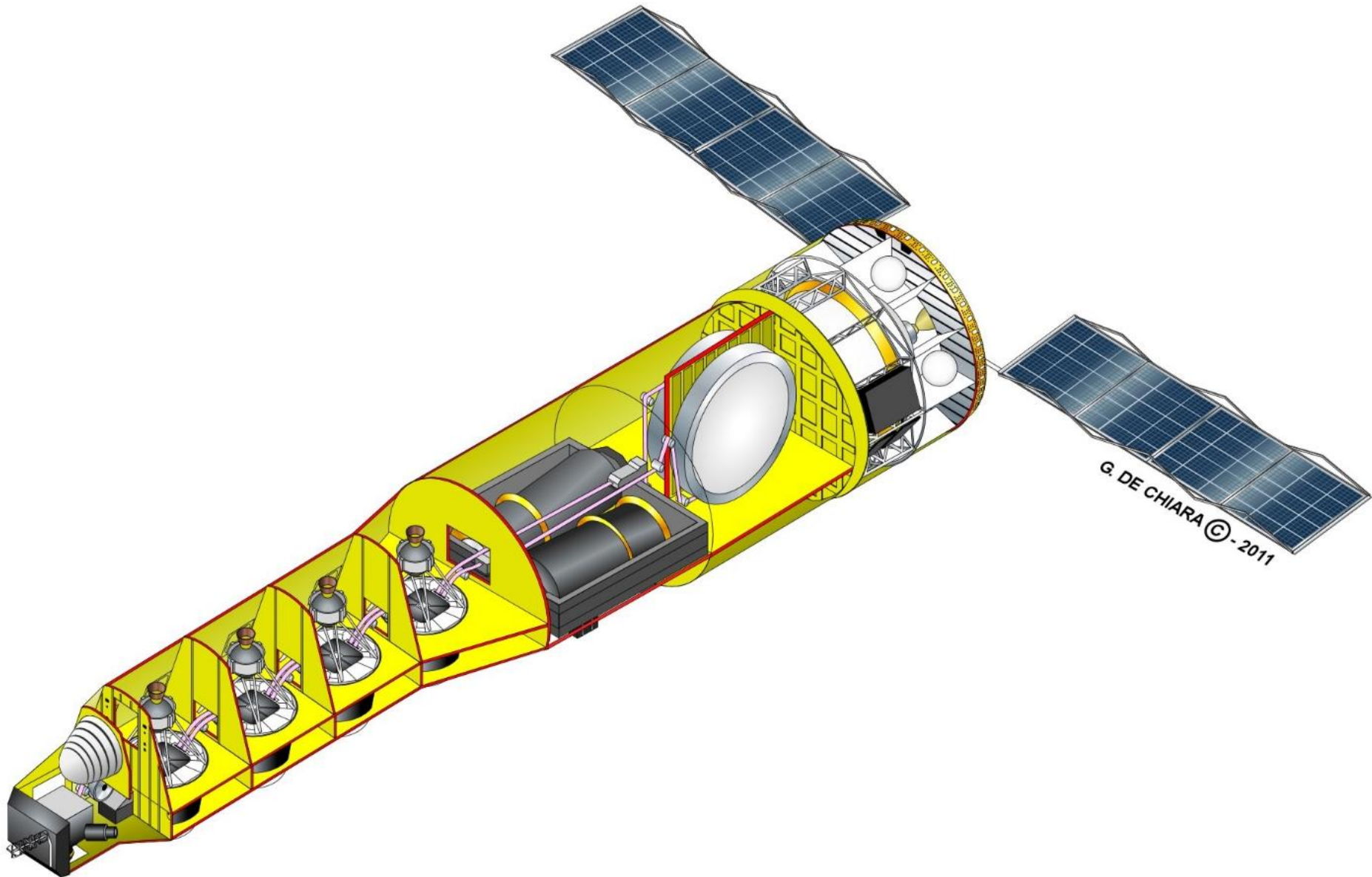

Hexagon



Horse Trailer or Hexagon on 101?



Agena

The Space Bus



Lockheed - Agena

Space Bus for Spy Satellites

- First restartable second stage
 - Boost and maneuvering
 - 3-axis stabilized
- Used ontop of Thor, Atlas and Titan
 - Controlled all 1960' s spy satellites
 - Originally built for WS-117L
 - Converted from the B-58 Bomb Pod
 - Had a special rack for SIGINT payloads
- 362 built on an assembly line in Sunnyvale

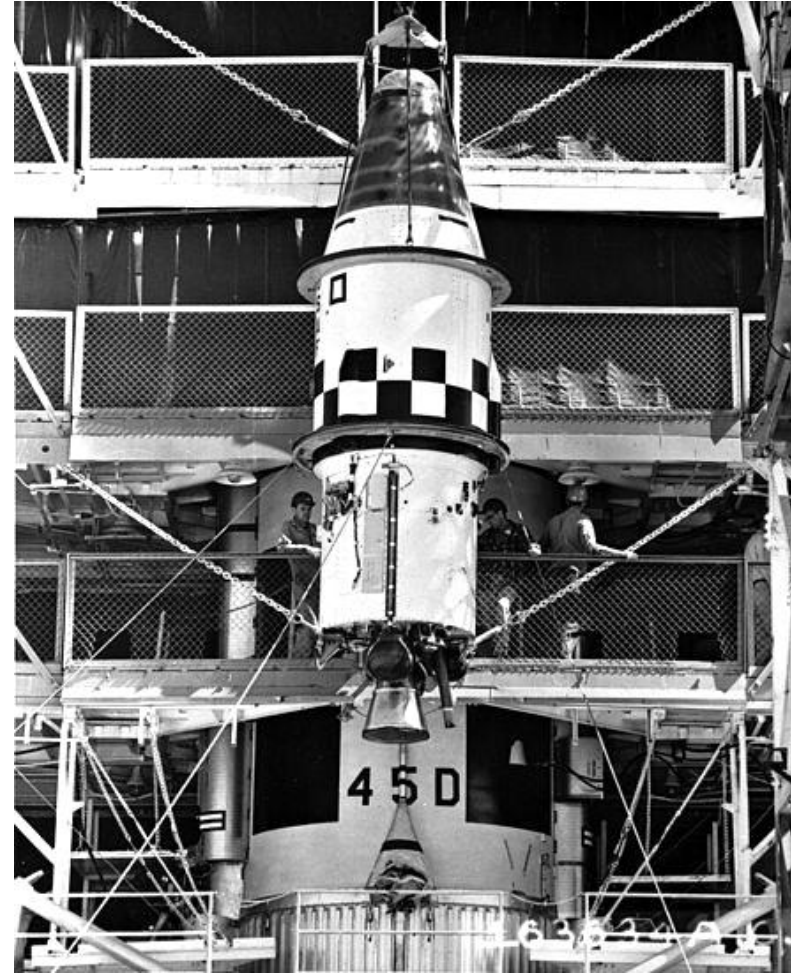

Agena

The Space Bus



Lockheed - Agena

Space Bus for Spy Satellites

- First restartable second stage
- Used on top of Thor, Atlas and Titan
 - Controlled all 1960' s spy satellites
 - Converted from the B-58 Bomb Pod
 - Had a special rack for SIGINT payloads
- 362 built on an assembly line in Sunnyvale



Lockheed - Agena

Space Bus for Spy Satellites

- Agena A, B and D models
 - 18 Agena A 1959-60
 - Bell Model 8048: XLR81-BA-5
 - Payload integrated
 - 75 Agena B 1960-66
 - Bell Model 8081: XLR81-BA-7
 - Payload integrated
 - Restartable
 - 269 Agena D 1962-87
 - Bell Model 8096: XLR81-BA-11
 - Restartable
 - Standard configuration

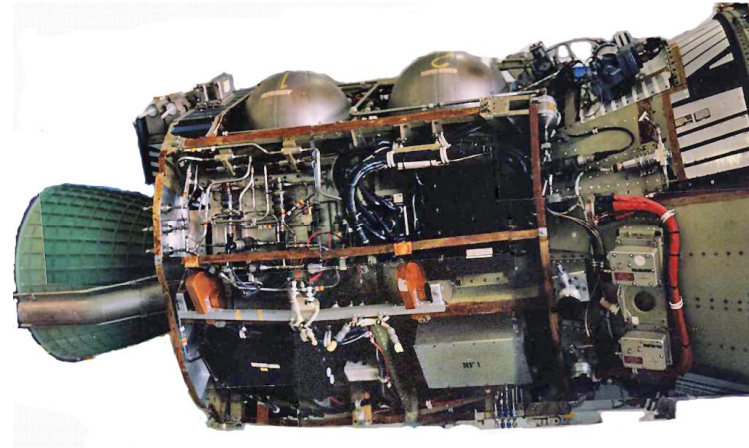

Lockheed in Santa Cruz 1957

- Rocket test facility in the Santa Cruz mountains
 - to support Agena, Polaris, Poseidon, Trident
 - 100's of rocket tests
- Rocket, ordnance and other tests



Lockheed in Santa Cruz

- 1957 Rocket test facility in the Santa Cruz mountains
 - to support Agena, Polaris, Poseidon, Trident
 - 100's of rocket tests
- Rocket and now ordnance and other tests

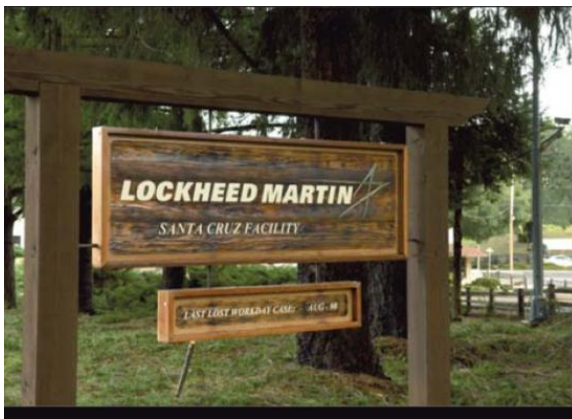

Space Pioneers In Santa Cruz Mountains

New Satellite Vehicles Are Perfected Among Old Redwoods



Newsmen in the Santa Cruz area are not long in noticing that public bodies are favoring economic and ways to cut frills in schools and other projects.

The Lockheed Martin and Space Division test base built in the Santa Cruz mountains north of Boulder Creek falls easily in line with the public mood.

Although the 40-acre base has been in development since the late 1950s, the hundreds of acres used for the Agena and Polaris tests have been "hatched" from the base.

The space vehicles are actually launched but tied down to the Agena in a satellite with its own engine. It is boosted into orbit by the 100-pound thrust of the Thor. Then in one 15,000-foot thrust, it is boosted to 15,000 m.p.h. into orbit. It will take an orbit 15,000 miles for four plus minutes to be used as a test.

It uses a hypergolic fuel mixture, which means that chemical reactions explode upon contact without the need of a spark. The Agena satellite system can be used for mission trials, launch and weather forecasting.

With proper training and instruction it could go to the moon or Mars, said Lockheed engineers.

This is part of the Air Force's Defense program.

The vehicles come to the base already assembled and following tests are sent to Vandenberg or Cape Canaveral for actual launch.

Shown in the photo below the Agena satellite is hoisted into place in the giant steel and concrete test stand as technicians make it ready for firing.



Part of the body of a missile extends through the center hole and is held steady by a powerful steel collar. A Lockheed spokesman said acid could be drawn on the white suit and it would roll off like water. The two photos at left show space engineers manning the control and instrumentation consoles in a test stand blockhouse. Within 15-inch walls they check hundreds of details before and during the test firing. Television monitors mounted above the consoles keep engineers in constant touch with critical firing areas outside. When something goes amiss they can turn off the power, but unlike at Vandenberg, the missile will still be around, saving millions of dollars. Below, is a scene at the actual firing of the Agena re-starting satellite engine Wednesday at the Santa Cruz base. Orange white clouds of smoke billowing forth hide the shreds of flame shooting out of the curved chute. A tremendous roar filled the air like a thousand cannons. One engineer said that heat temperatures inside the firing tubes reach about 3000 degrees.

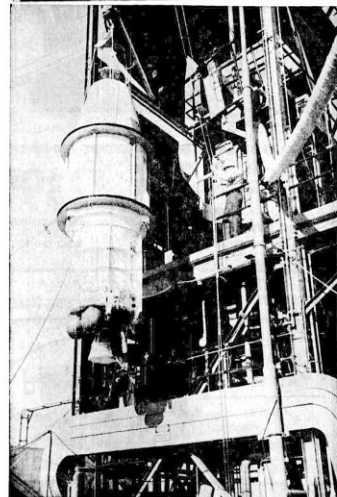
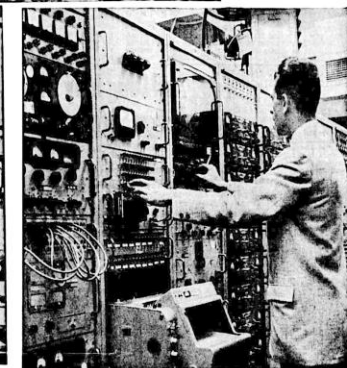

Left, the Agena satellite is hoisted into place in the giant steel and concrete test stand as technicians make it ready for firing. They are already assembled at the Lockheed plant in Sunnyvale and transported to the Santa Cruz test base. This is a second stage vehicle about 18 feet long, five feet in diameter and weighing 8500 pounds when fully fueled and 1700 pounds in orbit. It probably will be given its first boost by the powerful Thor rocket. Once in orbit it can be maneuvered by its own engine and can re-start itself when a change of orbit is called for.

Shown in the photo below the Agena satellite is hoisted into place in the giant steel and concrete test stand as technicians make it ready for firing.

Part of the body of a missile extends through the center hole and is held steady by a powerful steel collar. A Lockheed spokesman said acid could be drawn on the white suit and it would roll off like water. The two photos at left show space engineers manning the control and instrumentation consoles in a test stand blockhouse. Within 15-inch walls they check hundreds of details before and during the test firing. Television monitors mounted above the consoles keep engineers in constant touch with critical firing areas outside. When something goes amiss they can turn off the power, but unlike at Vandenberg, the missile will still be around, saving millions of dollars. Below, is a scene at the actual firing of the Agena re-starting satellite engine Wednesday at the Santa Cruz base. Orange white clouds of smoke billowing forth hide the shreds of flame shooting out of the curved chute. A tremendous roar filled the air like a thousand cannons. One engineer said that heat temperatures inside the firing tubes reach about 3000 degrees.

Left, the Agena satellite is hoisted into place in the giant steel and concrete test stand as technicians make it ready for firing. They are already assembled at the Lockheed plant in Sunnyvale and transported to the Santa Cruz test base. This is a second stage vehicle about 18 feet long, five feet in diameter and weighing 8500 pounds when fully fueled and 1700 pounds in orbit. It probably will be given its first boost by the powerful Thor rocket. Once in orbit it can be maneuvered by its own engine and can re-start itself when a change of orbit is called for.

AFTRACK and P-11

Is There Room on This Bus?



CENTRAL
INTELLIGENCE
AGENCY

Ferrets = SIGINT Collection

- **ELINT** Electronic Intelligence
- **COMINT** Communications Intelligence
- **TELINT** Telemetry Intelligence
- As payloads and sub-satellites on Corona, Gambit & Hexagon
 - Payloads = AFTRACK
 - Sub-satellites = P-11
- Then as dedicated SIGINT Satellites

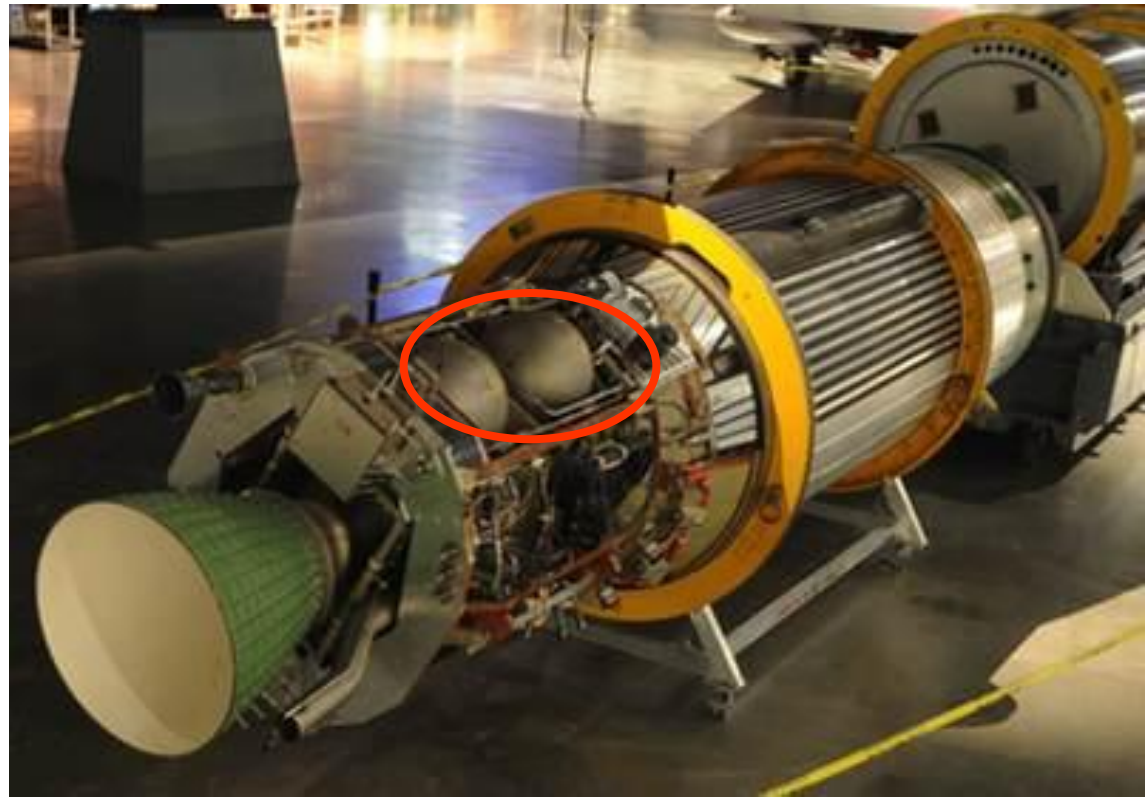

AFTRACK SIGINT Payloads

- Put small inexpensive, secondary payloads on the Agena of the Corona and Gambit imaging satellites
 - launched between Aug 1960-Oct 1967

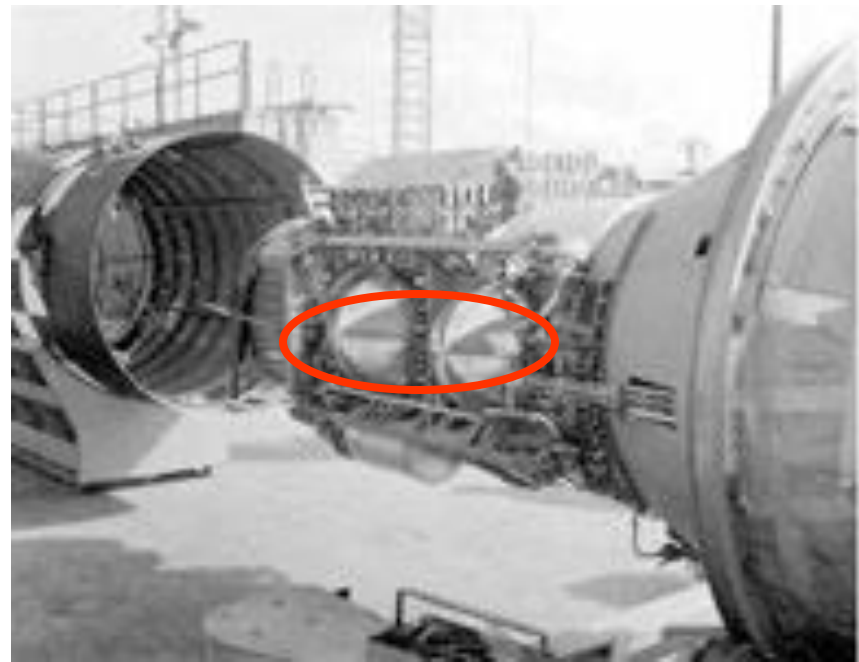
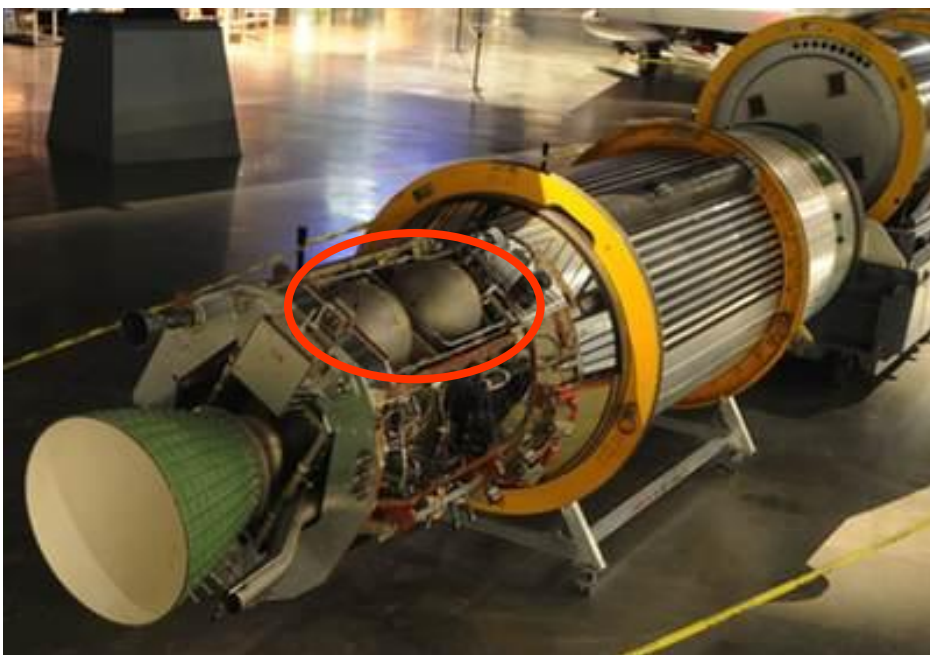

AFTRACK SIGINT Payloads

- Put small inexpensive, secondary payloads on the Agena of the Corona and Gambit imaging satellites
 - launched between Aug 1960-Oct 1967
 - First ones built at Stanford

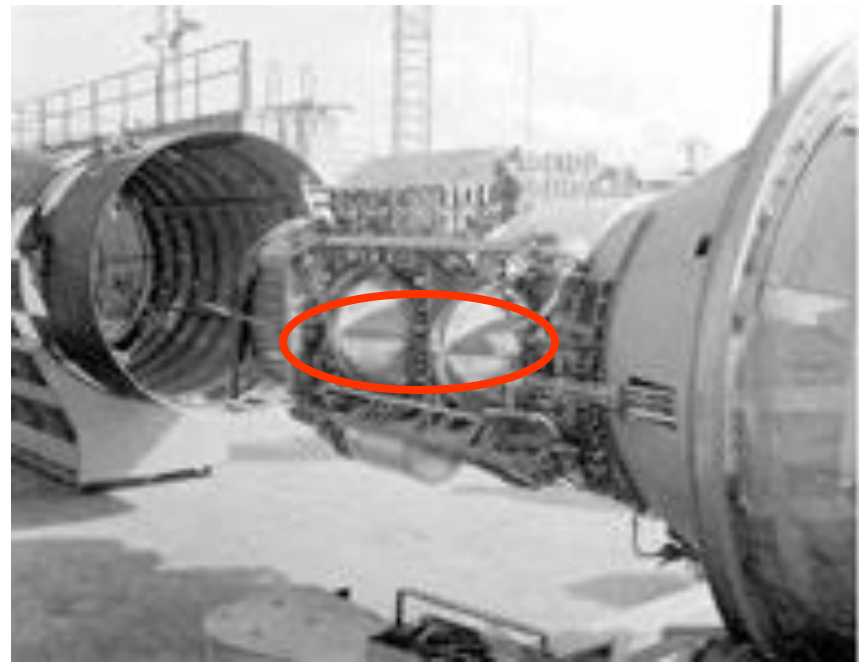
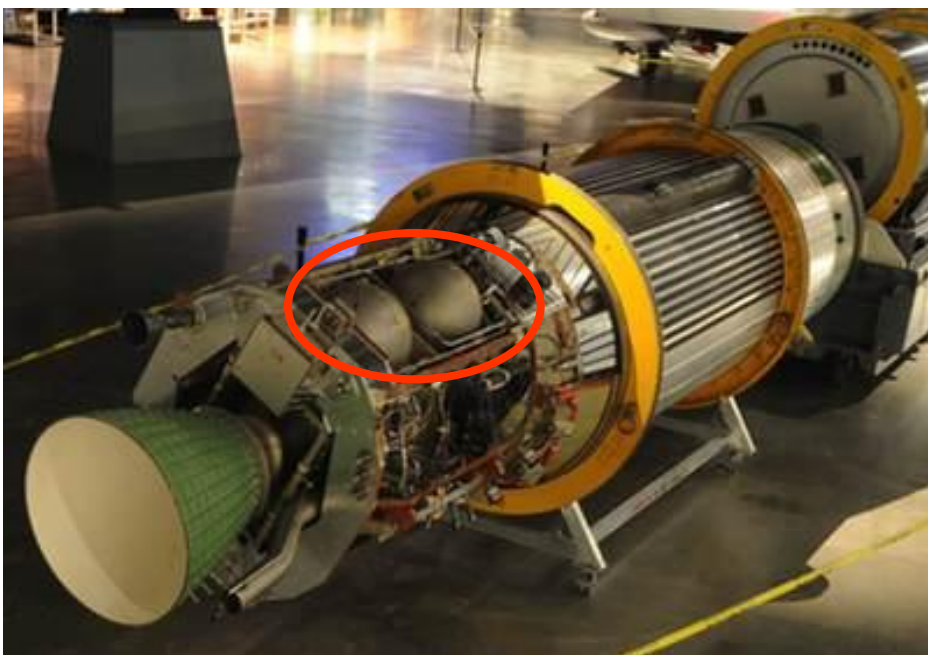

AFTRACK ELINT Payloads

- AFTRACK **ELINT** Ferret payloads
 - Built by SEL, Sylvania SDL, ATI & Lockheed
- Carried on Agena of Corona/Gambit
 - SOCTOP/STOPPER – Spoofing/Vulnerability
 - TOPSOC – 400mhz-1.6ghz search, no df
 - TAKI – find Tall King early warning radars
 - WILDBILL – find HENHOUSE ABM radar
 - LONGJOHN – find HENHOUSE center frequency
 - PLYMOUTH ROCK/HAYLOFT – Radar Order of Battle 2-4ghz

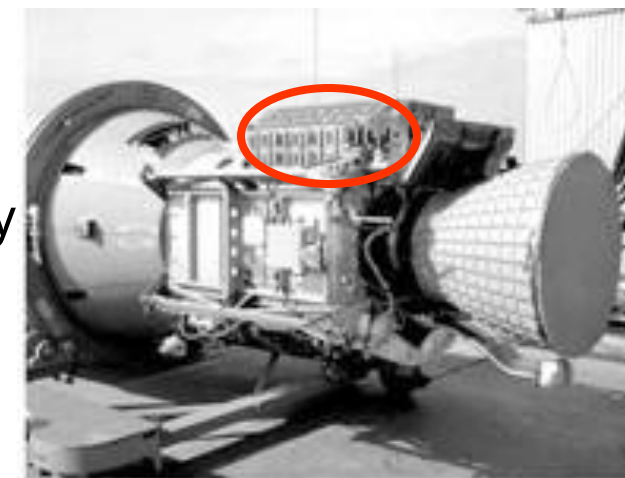
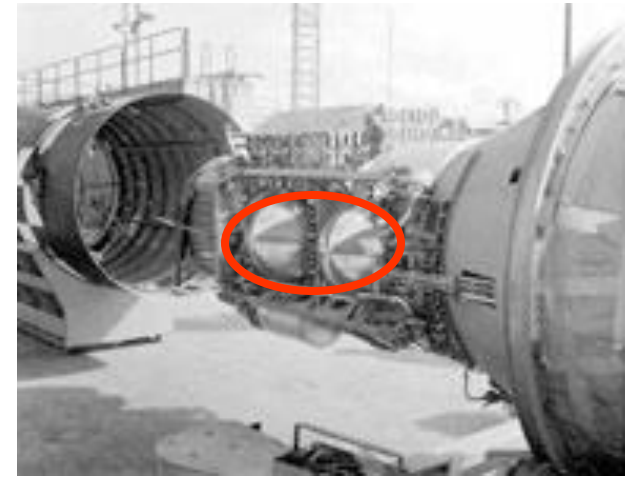

AFTRACK COMINT Payloads

- AFTRACK **COMINT** Ferret payloads
 - Built by AIL, Sanders, HRB Singer
- Carried on Agena of the Corona satellites
 - TEXASPINT– Air to Ground Communications
 - NEWJERSEY - Air to Ground Communications
 - NEWHAMPSHIRE – never flew
 - VINO – Comint copy
 - GRAPEJUICE – radio teletype (RTTY)
 - OPPORKNOCKITY – radio teletype (RTTY)
 - SQUARE TWENTY – 1.55-2Ghz comm link
 - DONKEY – sidelobes of 3.45-3.9Ghz comm link

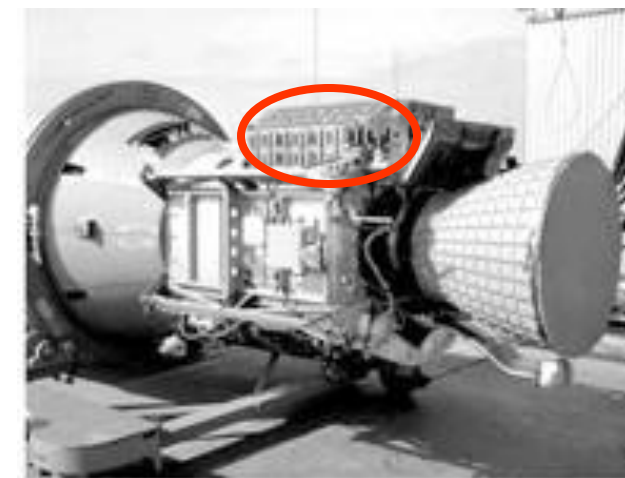
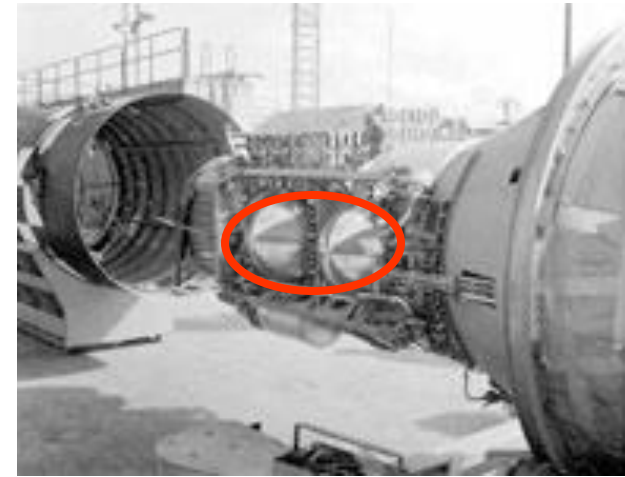

BIT-Boxes: Were We Being Tracked?

- AFTRACK payloads, tailored frequency to ABM radars
 - HENHOUSE, DOGHOUSE, TRYADD Search
 - Wanted to know if they were tracking Corona, Gambit and Hexagon
- Built by Sylvania EDL
- STOPPER first flown on Samos E-6 then BIT on Agena/Corona & Gambit and Hexagon
 - BIT-1: fixed 153-163 Mhz
 - BIT-2 sweep 150-300 Mhz
 - BIT-4 1967 fixed 152-164 Mhz + sweep 700-1000 MHz
 - BIT-4A added 1880-2020 and 2108-2245 MHz coverage
 - BIT - 9 Gambit/Hexagon – three receivers

Stanford SEL/Lockheed & AFTRACK

- SEL & Lockheed built the first AFTRACK Ferret sub-satellites
 - TAKI payload to track Tall Kings
 - WILDBILL –find HENHOUSE ABM radar
- Don Grace, SEL manager for AFTRACK payloads, set up a small lab in the basement of their building on the Stanford campus
 - single-handedly built all the 10 SEL payloads

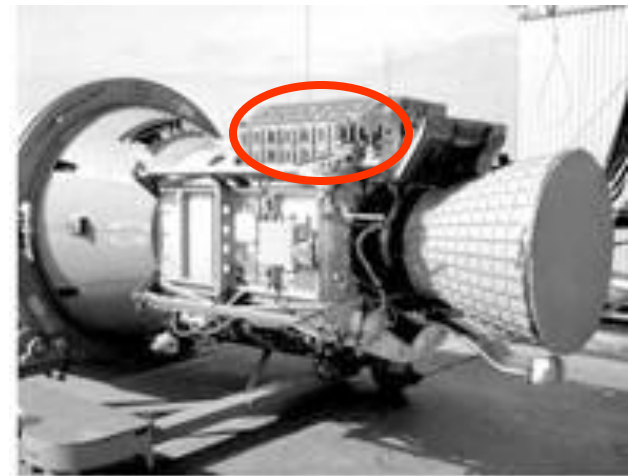
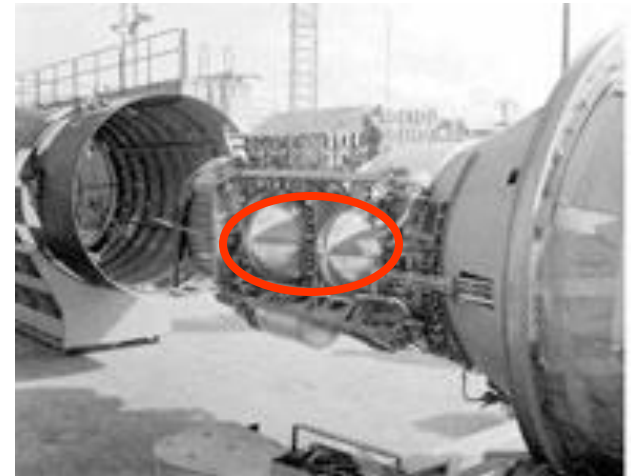

Program A, AFTRACK Sigint - 2

7201	PLYMOUTH ROCK 1	EQ 15530 3 310	11/24-12/01						5
7202	WILD BILL 2		12/12-12/15						3
7203	VINO 1		12/4-12/7						3
7204	TAKI 3		12/4-12/7						6
7205	NEW JERSEY 2		1/7-1/14						6
7206	VINO 2		2/28	(Failed to orbit)					0
7207	WILD BILL 3			6/12 6/26					13
7216	WILD BILL 4			6/15 7/20					35
7208	PLYMOUTH ROCK 2			6/29 7/11					12
7210	LONG JOHN 2				11/27 12/12				15
7218	LONG JOHN 1				12/21 1/10				20
7210	HAYLOFT				1/11 1/30				19
7222	LONG JOHN 3				2/15 3/9				23
7224	LONG JOHN 4					6/13 6/26			13

DC = Directed Coverage
 GS = General Search
 TI = Technical Intelligence

ABM = Antibalistic Missile
 COPY = Lock on Copy Content

Program A, AFTRACK Sigint - 3



1960/61 AFTRACK Payloads

Early AFTRACK Payloads

Name	Launch Vehicle	Date	Frequency (MHz)	Life	Remarks
SOCTOP I	Thor-Agena A (Discoverer 13)	10 August 1960	2500-3250	1 day	Vulnerability
SOCTOP II	Thor-Agena A (Discoverer 15)	13 September 1960	300-900 2500-3200	1 day	Vulnerability
SOCTOP III	Thor-Agena B (Discoverer 16)	26 October 1960	300-900 2500-3200	0	Failure; vulnerability
SOCTOP III	Thor-Agena B (Discoverer 17)	12 November 1960	1000-9000	2 days	Vulnerability
SOCTOP V	Thor-Agena B (Discoverer 22)	30 March 1961	100-1000	0	Failure; vulnerability
SOCTOP IV	Thor-Agena B (Discoverer 24)	8 June 1961	1000-6000	0	Failure; vulnerability
TAKII	Thor-Agena B (Discoverer 25)	16 June 1961	160-6000 (3 bands)	2 days	First recorder used. ABM radar; vulnerability
WILDBILL I	Thor-Agena B (Discoverer 26)	7 July 1961	40-150	0	ABM radar
TAKI	Thor-Agena B (Discoverer 28)	3 August 1961	160-175	0	No orbit. ABM search; vulnerability
Texas Pint I	Thor-Agena B (Discoverer 29)	30 August 1961	100-150	2 days	AM/FM environment signal
TOPSOC I	Thor-Agena B (Discoverer 30)	12 September 1961	400-1600 (2 bands)	5 days	ABM/GS
TOPSOC II	Thor-Agena B (Discoverer 31)	17 September 1961	400-1600 (2 bands)	4 days	ABM/GS
TOPSOC III	Thor-Agena B (Discoverer 32)	13 October 1961	400-1600 (2 bands)	2 days	ABM/GS
TOPSOC IV	Thor-Agena B (Discoverer 34)	5 November 1961	400-1600 (2 bands)	2 days	ABM/GS
GRAPEJUICE I	Thor-Agena B (Discoverer 36)	12 December 1961		1 day	
SOCTOP	Atlas-Agena B	22 December 1961	100-1000	7 months	Vulnerability

P-11/P989 SIGINT SubSatellites 1963 - 1983

- Subsatellites carried on Corona, Gambit, Hexagon and P770A, Strawman
 - Own rocket motors and solar cells
 - Boosted into their own special orbit
- Search for Telemetry, ABM, EOB, Tall King
- All had individual code-names
 - Pundit, NoahsArk, Step13, Plymouth Rock, Fanion Convoy, Magnum, Liege, Plicar, Ursula, Raquel, Farrah, Façade, Mabell, Lampan, Sampan, Sousea, Savant, Slewto, Tophat, Vampan, Weston
- Built by Sylvania EDL, ATI, HRB, ESL

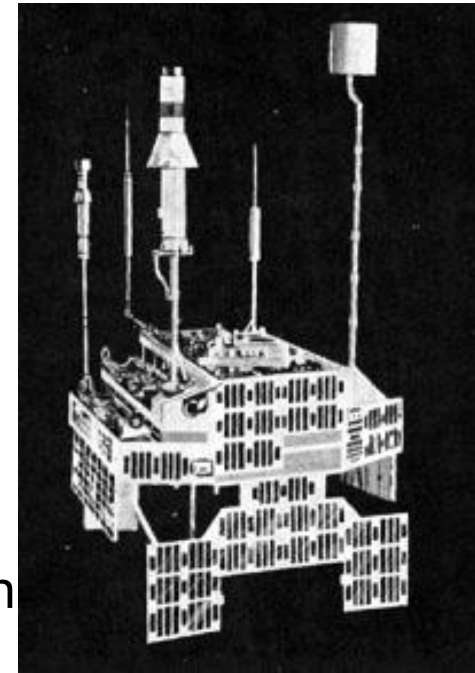

P-11 ELINIT Subsattellites P-801/989 1963 - 1983

Soviet ABM radars, communications, and military radars.

Table 2.4
Early P-989 Missions

Mission #	Name	Date	Frequency (Mhz)	Life	Remarks
7301	Pundit I	29 October 1963		19 months	VHF missile telemetry
7302	Pundit II	21 December 1963		3 months	VHF missile telemetry
7304	Noah's Ark	6 July 1964		135 days	TI on Soviet ABM
7303	Pundit III	8 October 1964		0	VHF missile telemetry
7305	Step 13	23 October 1964		123 days	GS for ABM
7306	Plymouth Rock III	23 October 1964		138 days	Flint, GS
7309	Pundit IV	28 April 1965		21 months	Telemetry
7307	Fanion I	25 June 1965		21 months	EOB, locate
7308	Tripos I	25 June 1965		22 months	Search and location on C-band
7312	Magnum	3 August 1965		21 months	ABM/Hea House

SIGINT Collection – General Search

- DYN0 1 – S-band
 - Continuous 60mhz – 10 Ghz search
 - 4 vehicles in orbit
 - DYN0 1 – S-band
- Poppy

The Air Force Gets SIGINT in Space

Heavy Ferrets

P-102/698BK/770/Multigroup/Strawman



Dedicated Agena for SIGINT

- Air Force “Cancelled” SAMOS
 - Became Program 102
- Four generations of low altitude SIGINT
- P-102/698
 - Fixed frequency combinations - called Group 1, 2, or 3 - had to be selected before launch
 - Agena-B P-102: Samos F-1 payload and Group 0-D, Group 1-D or Group 2-D ELINT payload; Plymouth Rock 2 ELINT (#4 only)
 - Agena-D: three deployable solar arrays + Group 1-A, Group 2-D or Group 3-D ELINT payload; Bird Dog ELINT payload (#1-4); Setter ELINT payload (#5)



Heavy Ferrets – Agena-based low-orbit Sigint 1962-1974

- Air Force Program
- Dedicated Agena carrying Sigint payloads
- Four generations of Sigint systems
 1. SAMOS Project F 1959-61
 2. Project 102/698BK/770 1962-65
 3. Multigroup 1966-68
 4. Strawman 1968-71



Strawman Subcontractors

Approved for Release: 2017/08/16 C05100032

~~TOP SECRET~~ / E

STRAWMAN PROGRAM MAJOR SUBCONTRACTORS

SUBCONTRACTOR

LOCATION

PRODUCT

LTV E-SYSTEMS

DALLAS, TEXAS

REAPER PAYLOAD,
CORE STORAGE UNIT

ALL

DEED BARK NEW YORK

THRESCHEP DAVI OAN

1960-65 Heavy Ferrets

WS-117L	Saturn III 698BK I	31 January 1961	P	Laurel Feltner Atlas Agena
Project 160	698BK II	21 February 1962	P	Thor Agena B
Project 102	698BK III	29 June 1962	P	Thor Agena B
Program 698BK	698BK IV	16 January 1963	P	Thor Agena D
Program 698BK	698BK V Flycatcher-Block	29 June 1963	P S	TAT Agena B* (*Thrust Augmented Thor)
Program 698BK	698BK VI Bird Dog I	22 February 1964	P S	TAT Agena D
Program 698BK	698BK VII Bird Dog I	1 July 1964	P S	TAT Agena D
Program 698BK	698BK VIII Bird Dog II	3 November 1964	P S	TAT Agena D
Program 770	698BK/770 Bird Dog III	16 July 1965	P S	TAT Agena D

Source: Busher and Chaid, p. 19.

~~(S)~~ Unlike satellite photography, this information was directly useful for

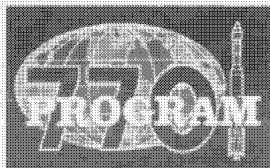

PAYLOAD FREQUENCY COVERAGE (U)

1962-1972

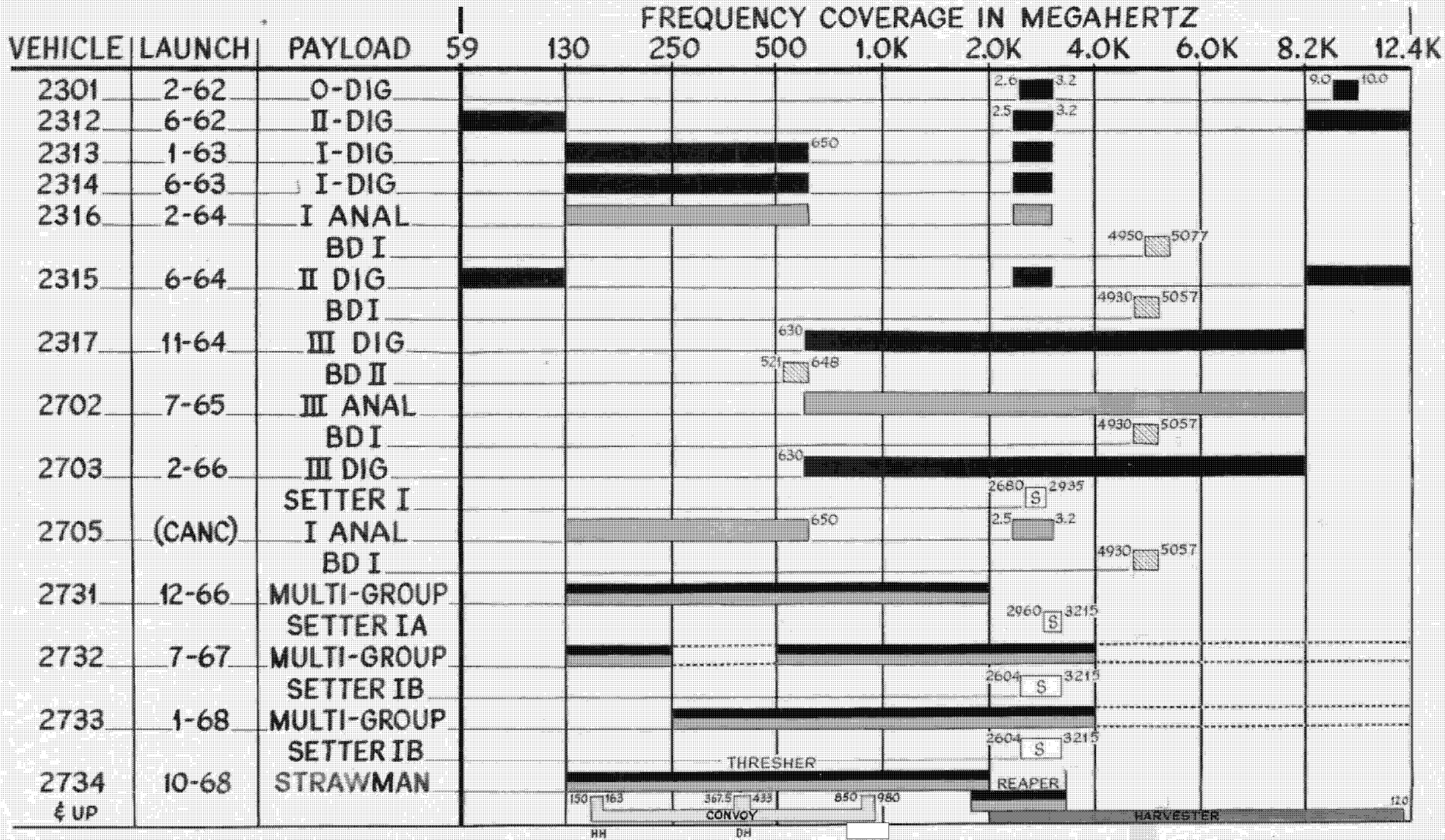

~~TOP SECRET~~ / E

HANDLE VIA BYEMAN
CONTROL SYSTEM ONLY

Program A (AirForce)

Agena-based low-orbit Sigint - 1

	PAYLOAD	are ELINT)	1900	1901	1902	1903	1904	1905	Days
N/A	SAMOS 1 (F-1 PAYLOAD)	GS	10/11						Booster failure
N/A	SAMOS 2 (F-1 PAYLOAD)	GS	1/31	2/1					1
7151	102 Group 0-D	EOB			2/21	2/27			6
7152	102 Group 2-D	EOB			6/18				1
7153	698BK Group 1-D	EOB			1/16	1/18			2
7154	698BK Group 1-D	EOB				6/29	7/9		10
7156	698BK Group 1-A	DC/TI				2/27	3/11		12
7212	BIRD DOG 2	EO 13526 1,4 EOB				2/27	3/13		15
7155	698BK Group 2-D	EOB				7/2	7/7		5
7211	BIRD DOG 1	EO 13526 1,4 EOB				7/3	7/8		5
7157	698BK Group 3-D	EOB				11/3	11/7		4
7213	BIRD DOG 3	VHF EOB				11/3			Antenna failure
7158	770 Group 1	DC/TI						7/16	9/5
7226	BIRD DOG 4	EO 13526 1 EOB						7/16	Power supply failure

GS = General Search
TI = Technical Intelligence

EOB = Electronic Order of Battle
ABM = Antibalistic Missile

DC = Directed Coverage
VHF = Very High Frequency

Program A (Air Force)

Agena-based low-orbit Sigint - 2

7229	SETTER 2A	S-BAND EOB	12/28	5/19				5 mos
7162	770 MULTI- GROUP 2	GS/DC/TI EOB		7/24 12/28				5 mos
7230	SETTER 1B	S-BAND EOB		7/24 12/28				5 mos
7163	770 MULTI- GROUP 3	GS/DC/TI EOB			1/17	4/3		14 mos
7232	SETTER 1B	S-BAND EOB			1/17	4/3		14 mos
7164	STRAWMAN 1; THRESHER 2	GS/DC/TI EOB			10/5	9/27		12 mos
7233	REAPER 1	GS/DC/TI EOB			10/5	9/27		12 mos
7238	CONVOY1	ABM DC/TI			10/5	9/27		12 mos
7165	STRAWMAN 2; THRESHER 2	GS/DC/TI EOB				7/31 9/27		13 mos
7234	REAPER 2	GS/DC/TI EOB				7/31 9/27		13 mos
7239	CONVOY 2	ABM DC/TI				7/31 8/30		31 days

GS = General Search
TI = Technical Intelligence

EOB = Electronic Order of Battle
ABM = Antibalistic Missile

DC = Directed Coverage



Program A (AirForce)

Agena-based low-orbit Sigint - 3

Chaos

Space Reconnaissance Land Grab

SIGINT Gets Crowded 1960-63

- **50** SIGINT Vehicles in Orbit
 - General Search
 - Radar Order of Battle
 - Directed Search

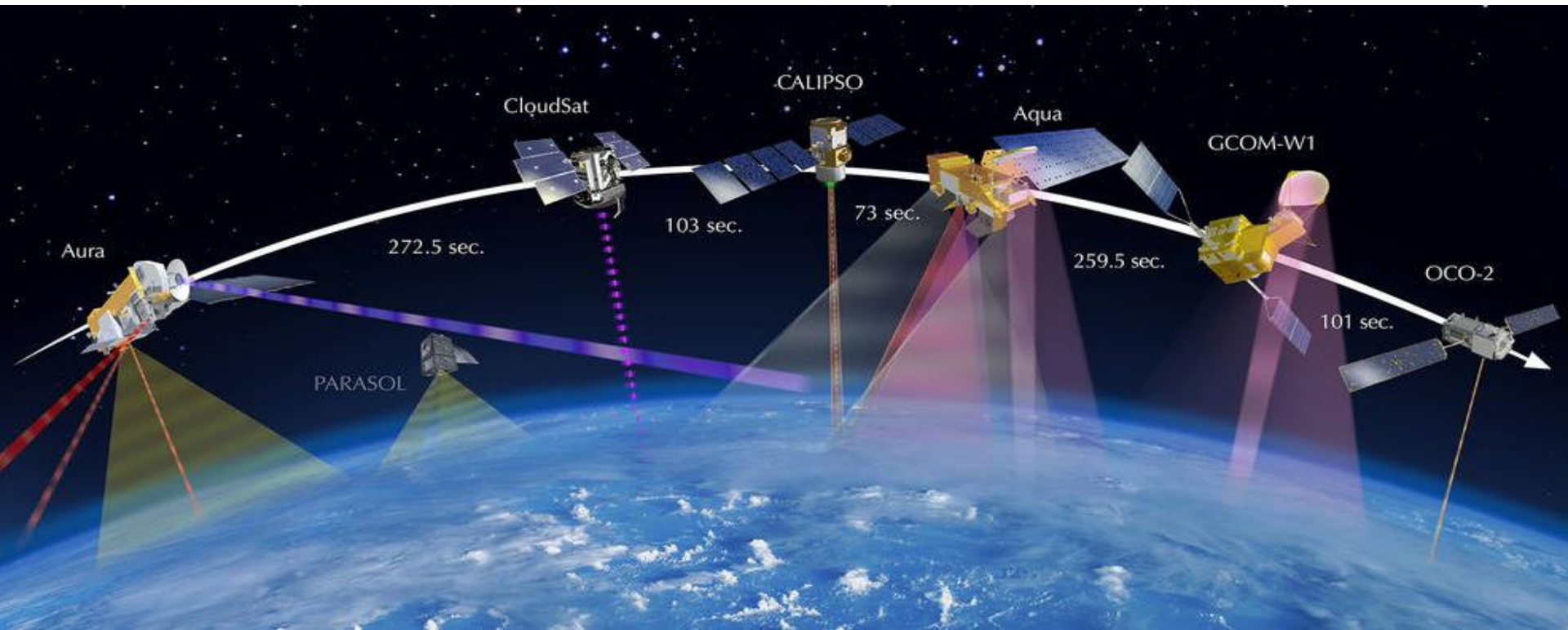

SIGINT Satellite Collection 1960-63

- **50** SIGINT Vehicles in Orbit
 - AFTRACK
 - Project 698BK/770, Project 102, MultiGroup, Strawman
 - 50% met their intelligence objectives
- General Search
 - Continuous 60mhz – 10 Ghz search
- Radar Order of Battle
 - For B-52s SIOP
- Directed Search
 - High priority: ABM, ICBM & COMINT systems

WS-117L Sentry – Recon Systems

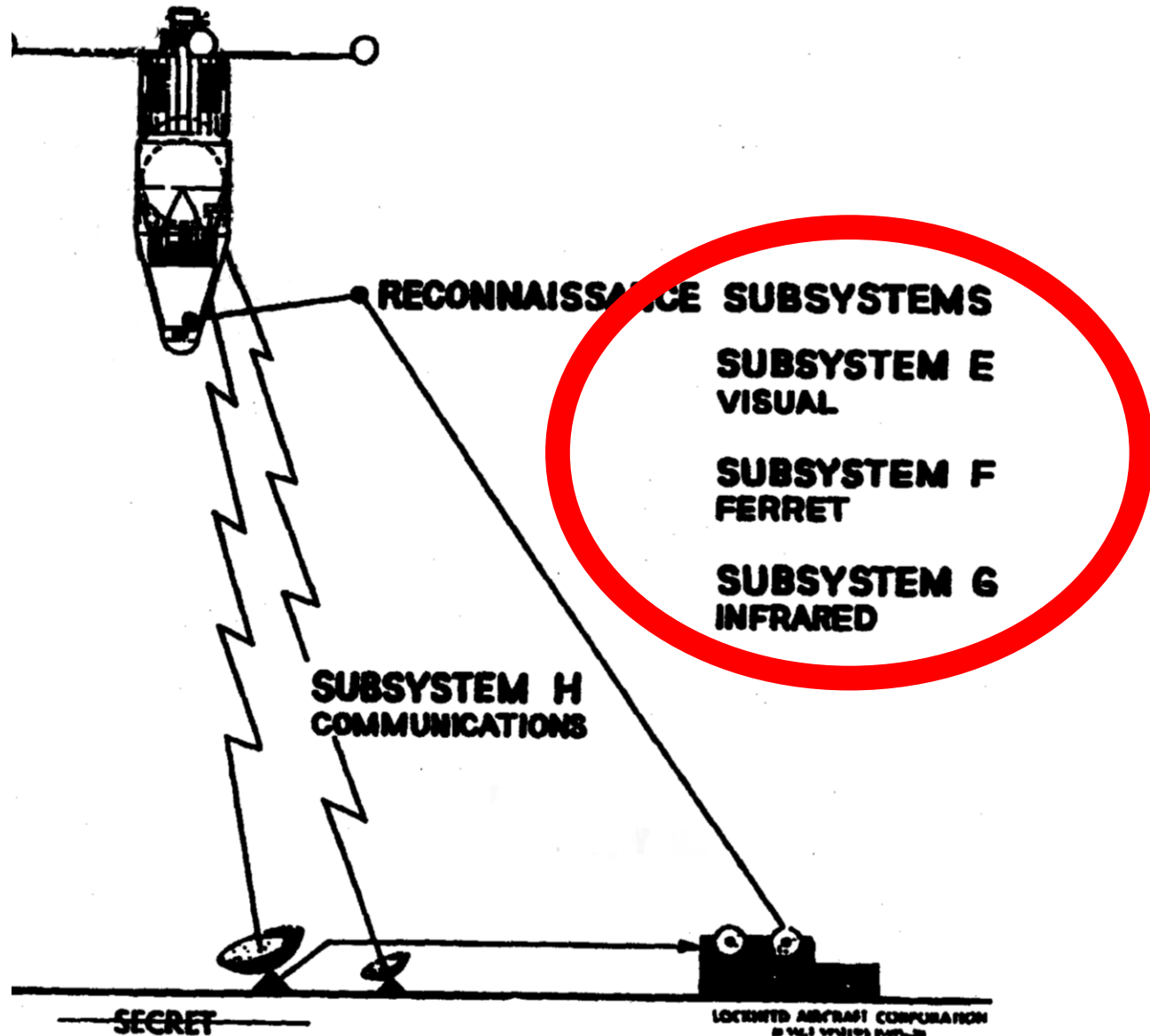

WS-117L – Becomes Separate Programs

Everyone Has A Piece

**SUBSYSTEM E
VISUAL**

→ *CIA: Corona* > *Gambit* > *Hexagon*

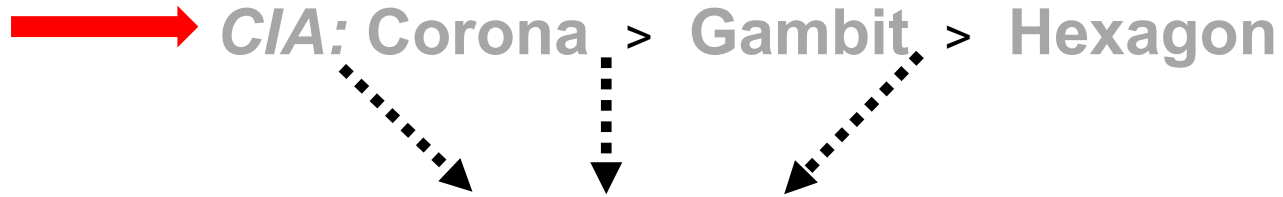

CIA: AFTRACK and P11

**SUBSYSTEM F
FERRET**

→ *Air Force: P102* > *P698* > *P770* >
Multigroup > *Strawman*



Navy: Grab > *Poppy*

**SUBSYSTEM G
INFRARED**

→ *MIDAS* > *P461* > *P 949* > *P 647* > *DSP*

Order Out of Chaos

The National Reconnaissance Office (NRO)



National Reconnaissance Office (NRO)

- Established in 1961 to consolidate the nation's overhead reconnaissance efforts
 - Air force (program A)
 - CIA (program b)
 - Navy (program c)
 - U-2, SR-71/A-12 aircraft, TagBoard drone (program d)

Organizations Involved in Sigint – WW2 - 1954

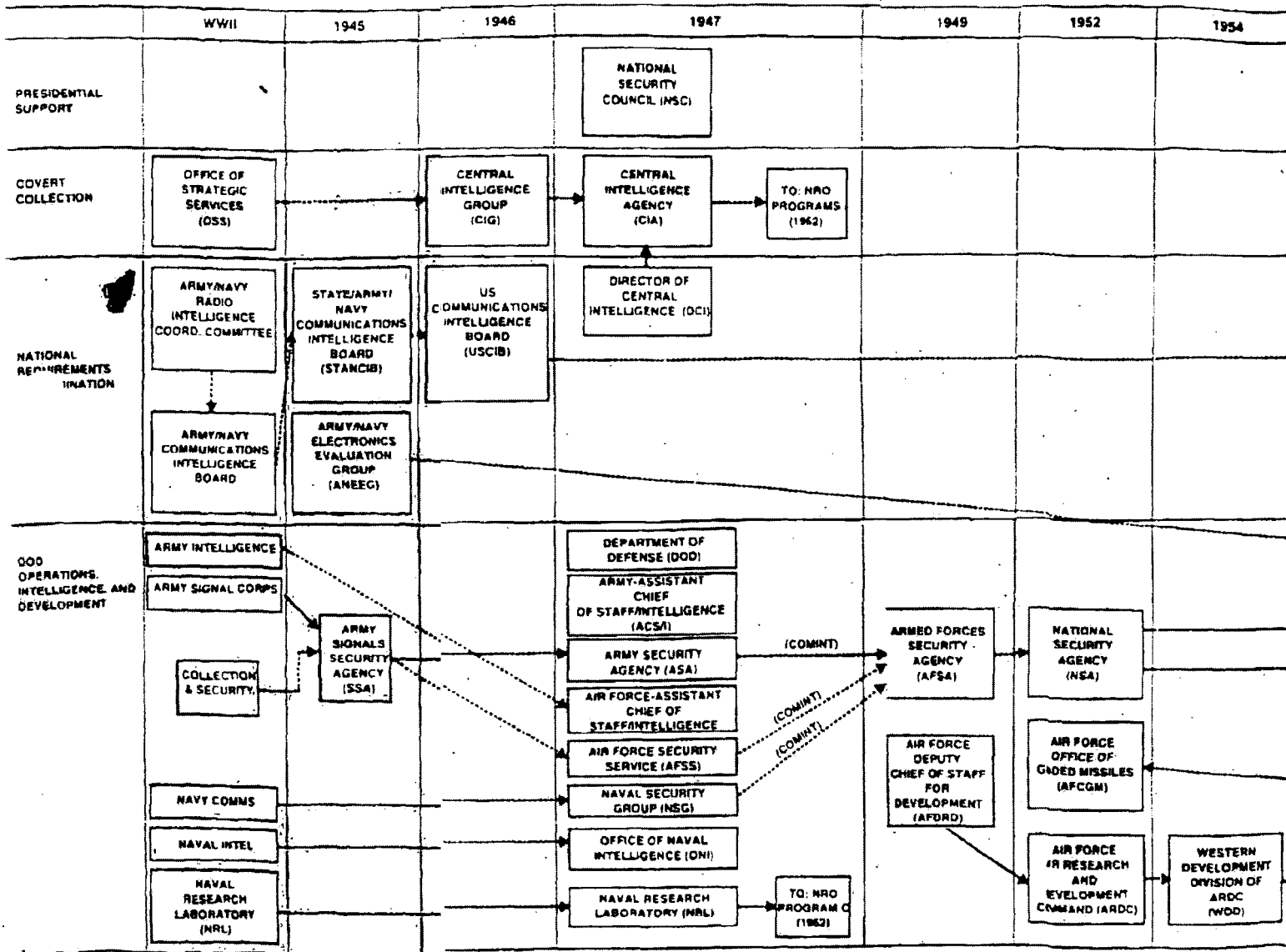

Organizations Involved in SIGINT – 1956-62

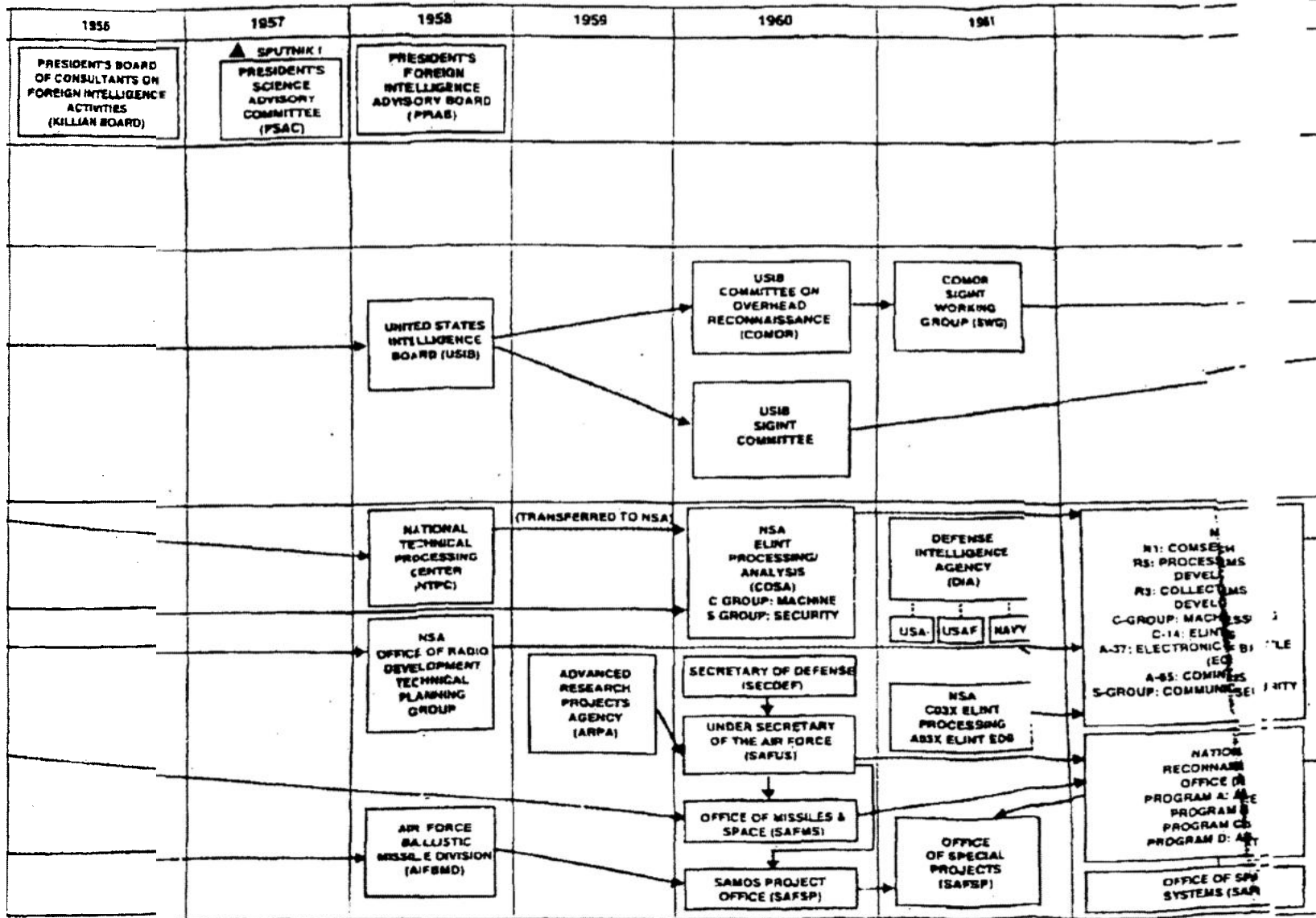

Organizations Involved in SIGINT – 1975

LEGEND
 INDICATES TRANSITION
 _____ INDICATES SUBORDINATION

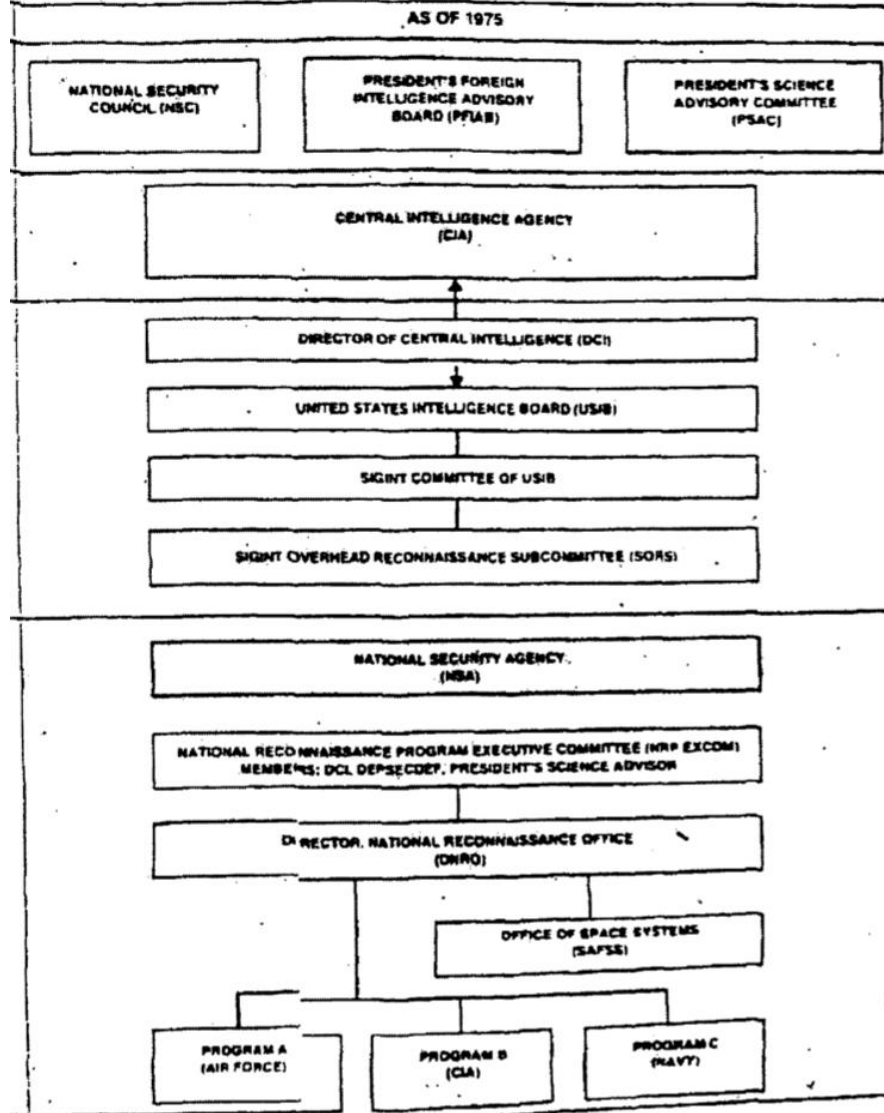

Lockheed and WS-117L

NRO - Move Reconnaissance to Space

CORONA

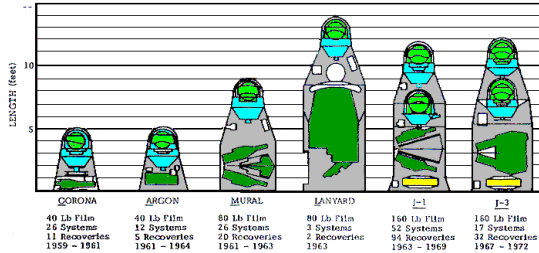

SAMOS/SENTRY

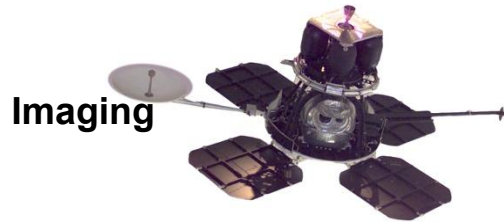

Program P-11/ 989 SAMOS F-1/2/3

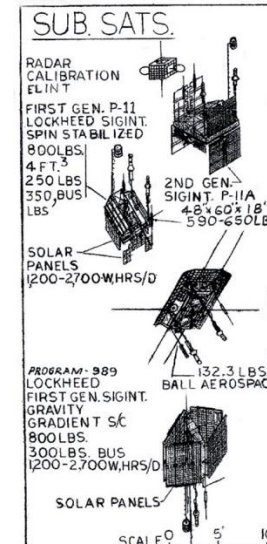

ELINT/SIGINT

MIDAS - Program 461

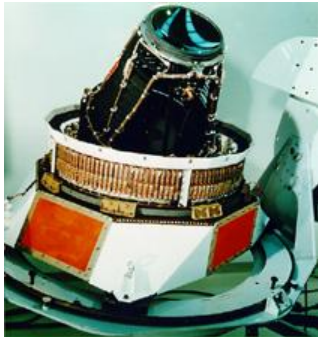

IR - Launch Detection

VELA

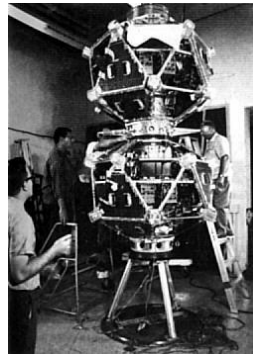

Nuclear Detection

Program A: Air Force - imaging and sigint
 Program B: CIA - Imaging electrooptical and sigint
 Program C: Navy sigint
 Program D: U-2, A-12/Oxcart, D-21/Tagboard

Evolution of American Reconnaissance Systems

The drawings are at same scale

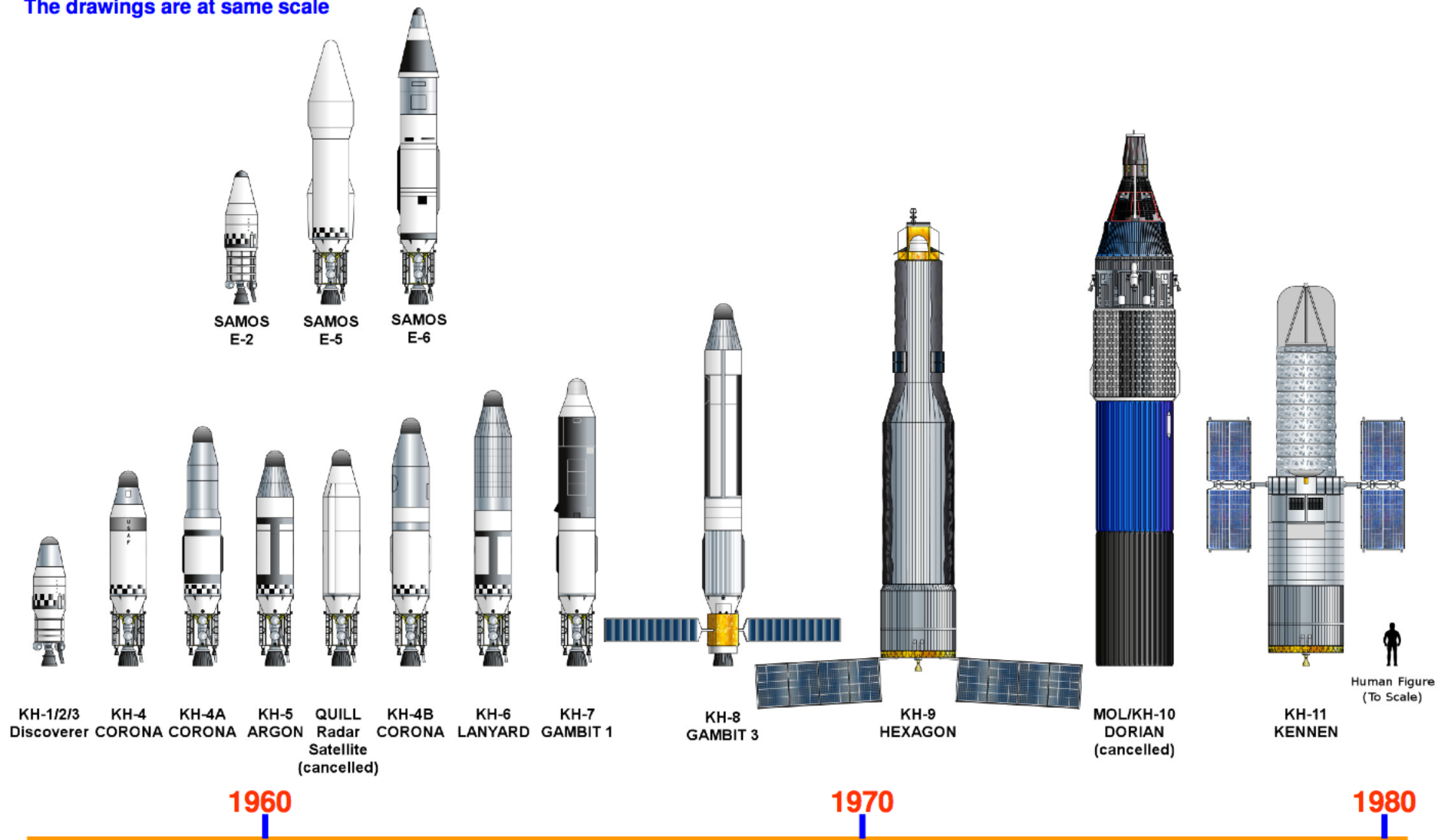

From the initial CORONA to the MOL/DORIAN proposal, spy satellites went through several generic evolutions depicted here. From left: KH-8 GAMBIT-3; Manned Orbiting Laboratory/DORIAN; KH-4B CORONA. (Ian Moores)

Key for KH-8 GAMBIT-3

- 1 Two film recovery capsules
- 2 Camera and film take-up spools
- 3 Mirror assembly
- 4 Telescope and optics module
- 5 Roll control joint
- 6 Agena stage propellant tanks
- 7 Solar arrays
- 8 Bell rocket motor

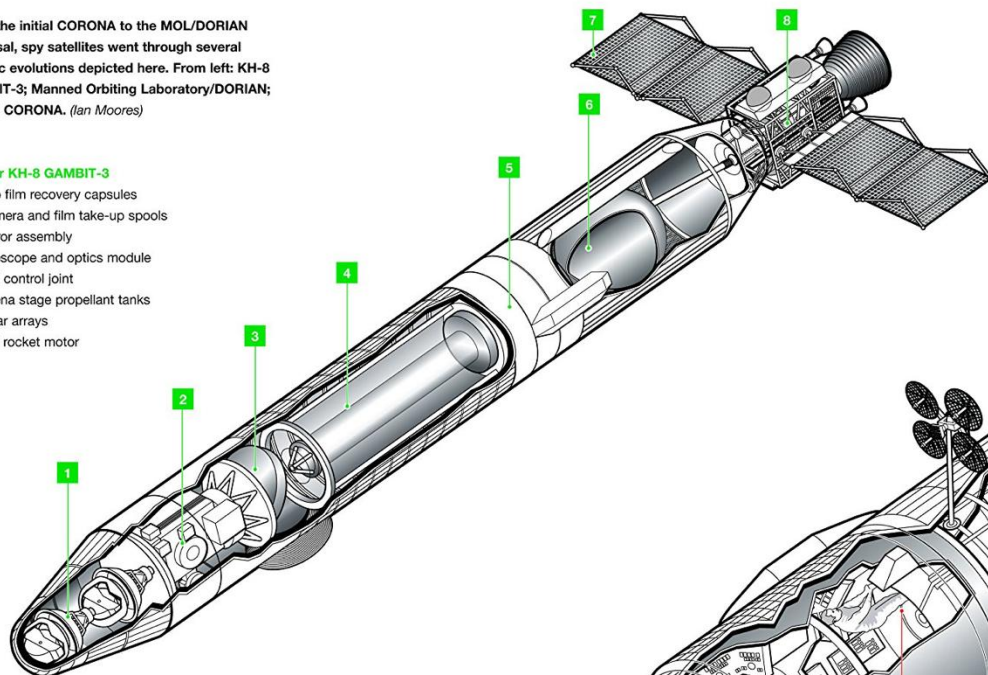

Key for MOL/DORIAN:

- 1 Gemini spacecraft re-entry module
- 2 Gemini adapter section with access to MOL
- 3 MOL access tunnel through unpressurised section
- 4 Pressurised work and living space
- 5 Operating stations for targeting specific areas for photography
- 6 Camera systems and optics
- 7 Telescope

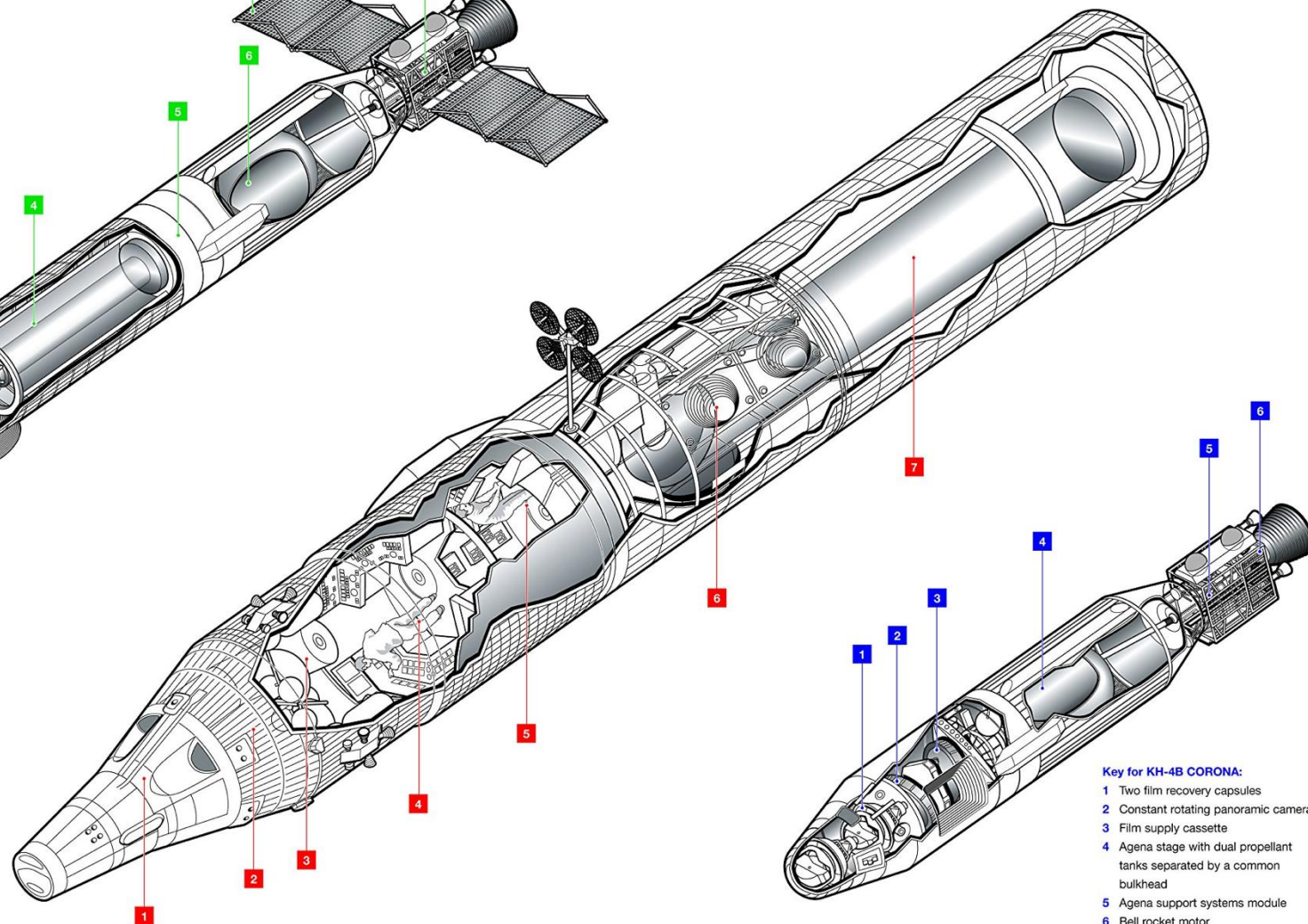

Key for KH-4B CORONA:

- 1 Two film recovery capsules
- 2 Constant rotating panoramic cameras
- 3 Film supply cassette
- 4 Agena stage with dual propellant tanks separated by a common bulkhead
- 5 Agena support systems module
- 6 Bell rocket motor

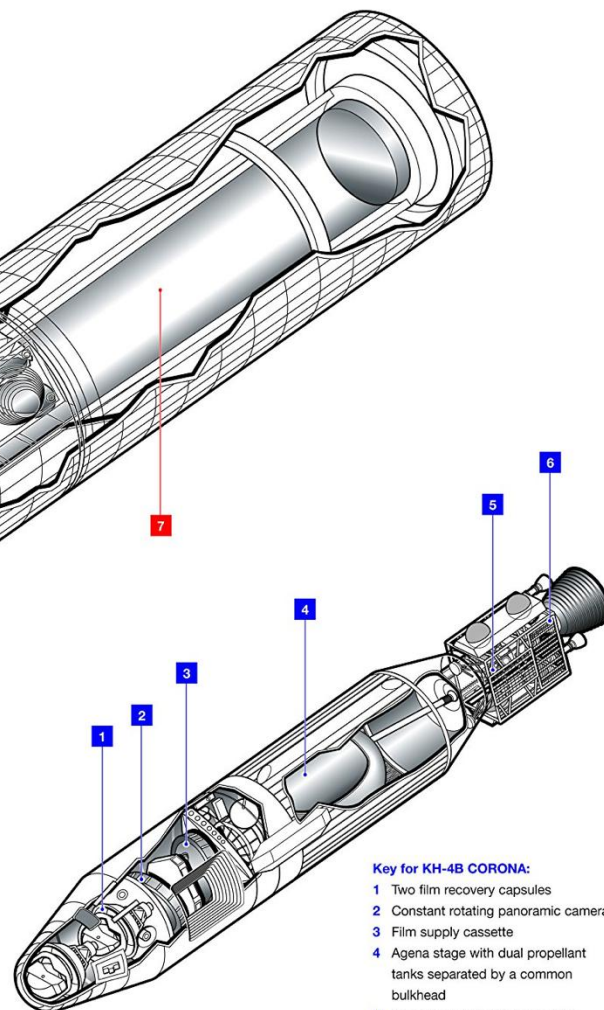

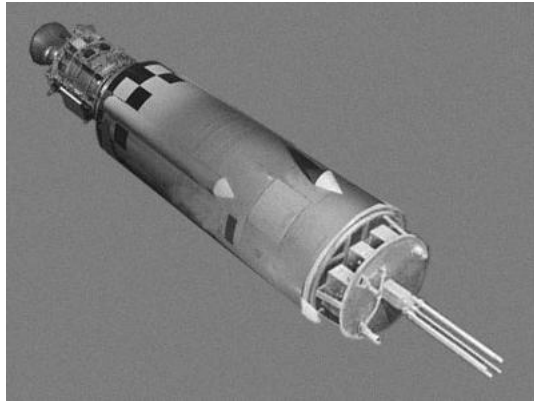

P-102 / P-698BK / P-770

Agena-B



MultiGroup

MultiGroup, Setter, Donkey

Agena-D

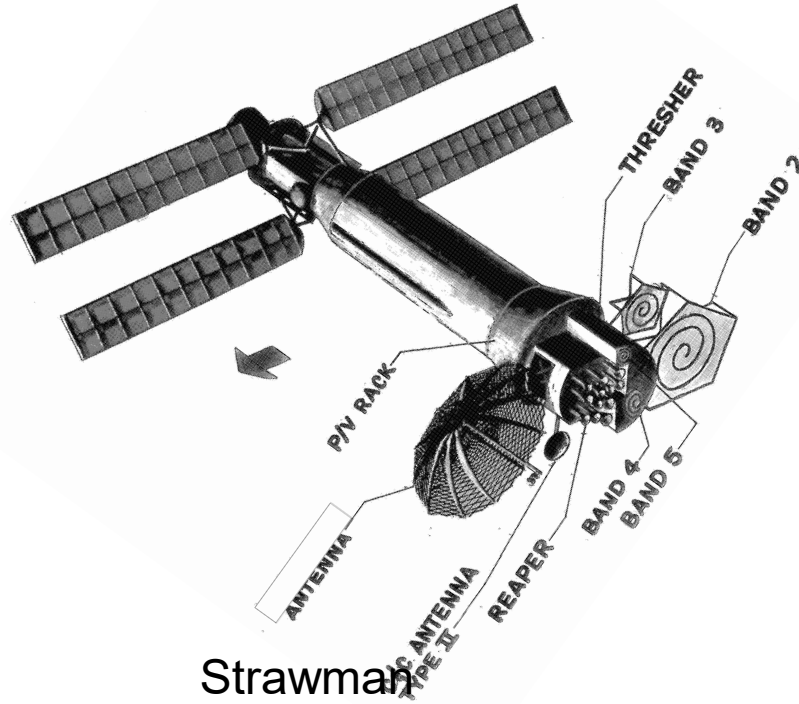

Strawman

Thresher, Reaper, Convoy and Harvester

Agena-D

Tubes

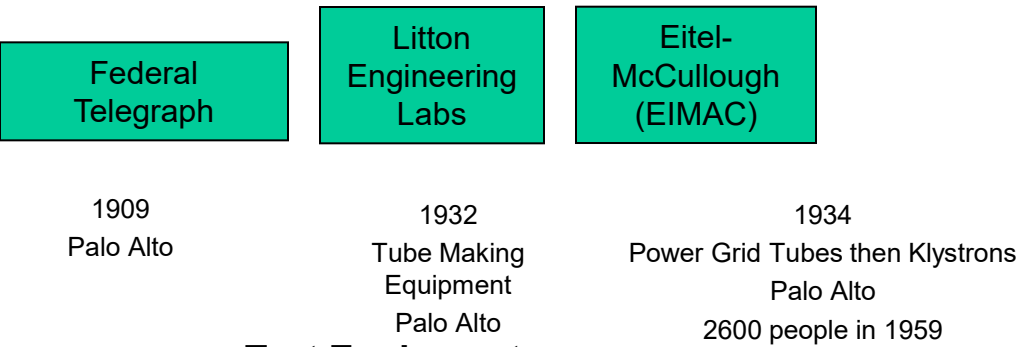

Test Equipment

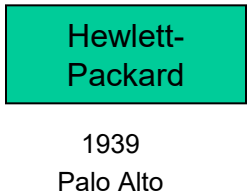

Microwave Components

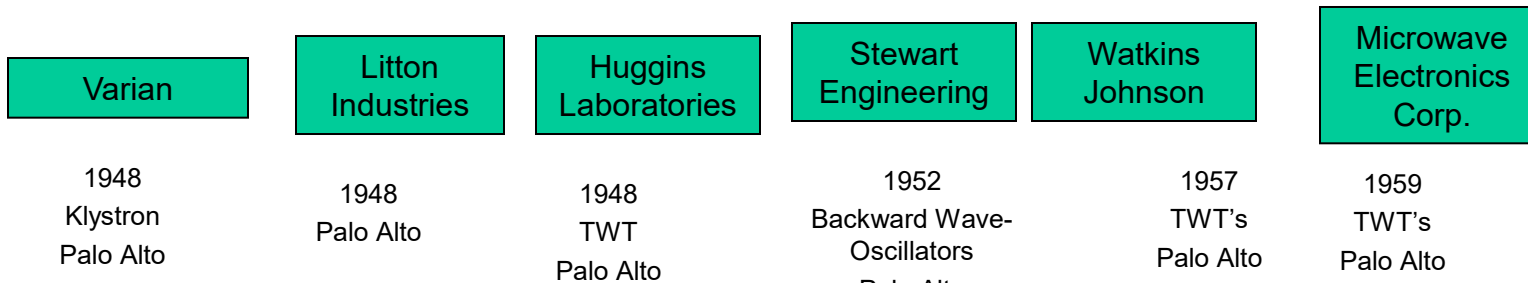

Microwave Systems

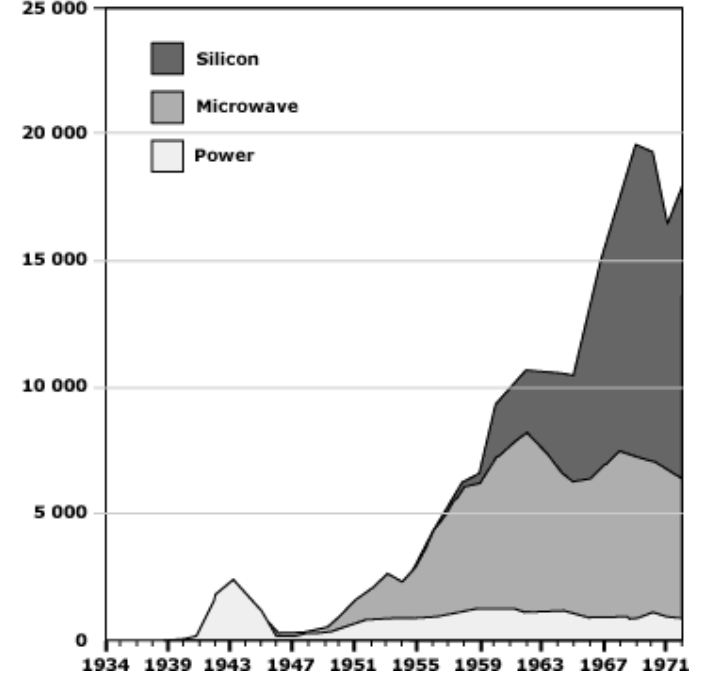
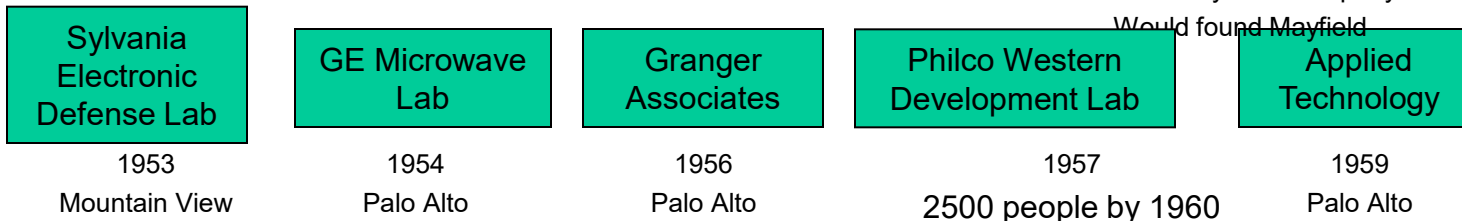



SEL/Lockheed and de Broekert

- James de Broekert of Stanford STL
- SEL & Lockheed built AFTRACK Ferret sub-satellites
- Carried on Agena of the Corona photo satellites
 - AFTRACK – TAKI payload to track Tall Kings
 - WILDBILL – to find HENHOUSE ABM radar
 - launched between Mar 1963-Oct 1965
- Founded Argo, Signal Science, Advent Systems

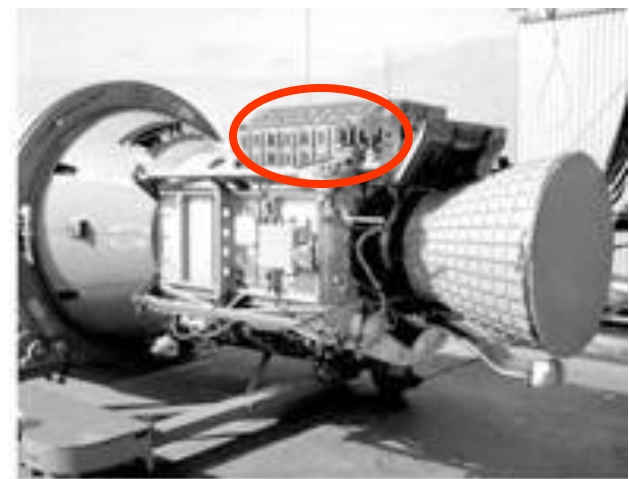
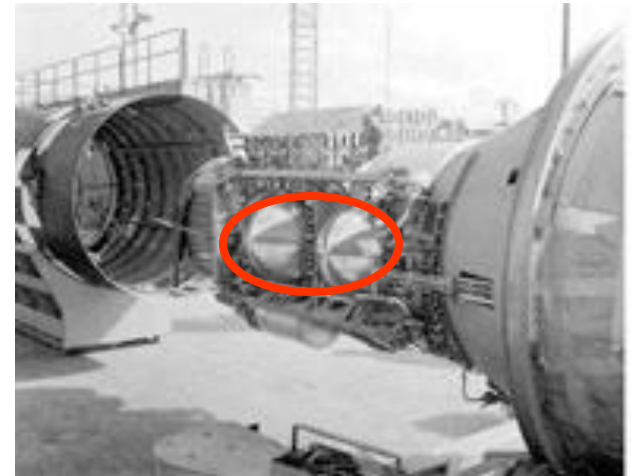



Stanford AEL/STL and Rambo

- William Rambo
 - Designed “Carpet” Jammer at RRL
 - Went to AIL after WWII, Stanford - 1951
 - Headed AEL then STL - 1958
 - NSA/CIA consultant
- Stanford STL leads the space ELINT effort
 - Works with Lockheed on ferret subsatellites

Project West Ford 1963

A Ring of Chaff in Space

- 400 million copper dipoles
- 3/4' s of an inch long
- 2000 mile altitude, 5 miles wide, 25 miles thick
- Cover was “radio relay” tests
- Launched as part of MIDAS

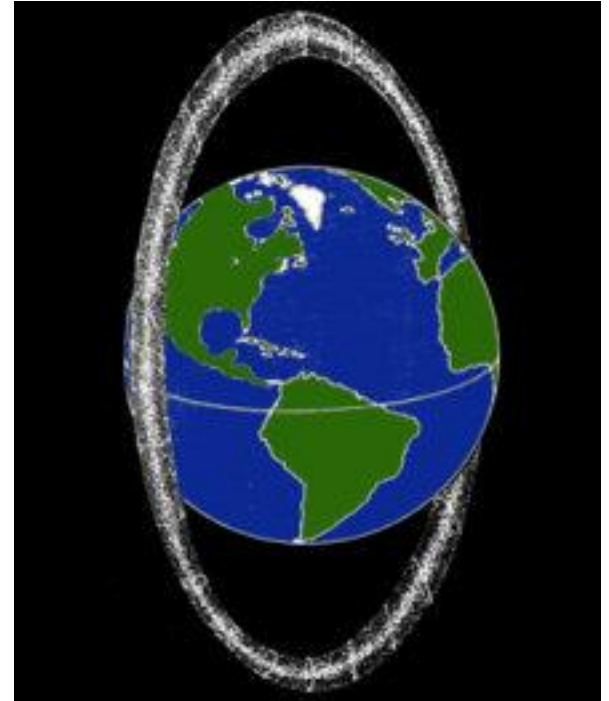



Villard and Over the Horizon Radar

- Meteor trails
 - burst comm and ELINT receiver
- Nuclear tests
- OTH - Over The Horizon Radar
 - Monitor missile launches
 - EARTHLING in Pakistan in 1961
 - CHECKROTE in Taiwan in 1966
 - Aircraft tracking
- Stealth - 1969 at SRI

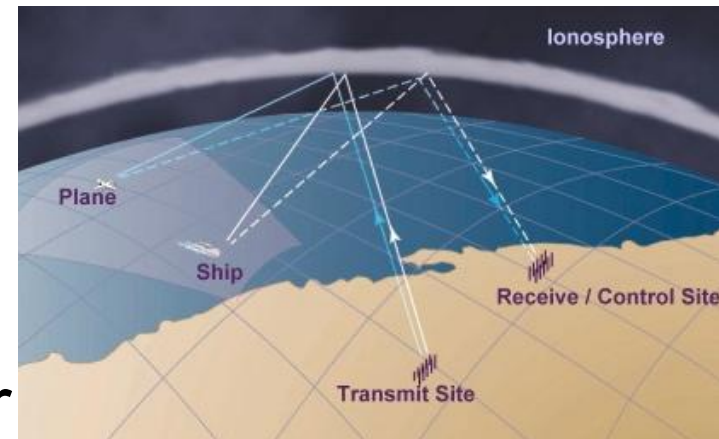

The End of Classified Work at Stanford

- In 1968, 35 percent of Stanford research funding in electronics was for classified work
- 50% of SRI's work was from DOD
- April 9, 1969 400 students occupy AEL



Story 7: 1966 Vietnam and Electronic Warfare

1966 Vietnam and Electronic Warfare

- 25 July 1965 an RB-66C ELINT aircraft monitoring the EOB (Electronic Order of Battle) of North Vietnam, located
- **Fire Control Radars**
 - 1 **SCR-5841**
 - 1 **SON-4**
 - 21 **SON-9**
 - 1 **Fan Song**
 - And the Electronic Warfare battle started

SON-4 (Whiff) SON-9 (Fire Can) AAA Control Radars

- During WW-II, US supplied SCR-584 (10cm wavelength, E band) Conical Scanning AAA Fire Control radars to the Soviet Union
- The Soviet Union copied it as the SON-4 and updated it as the SON-9

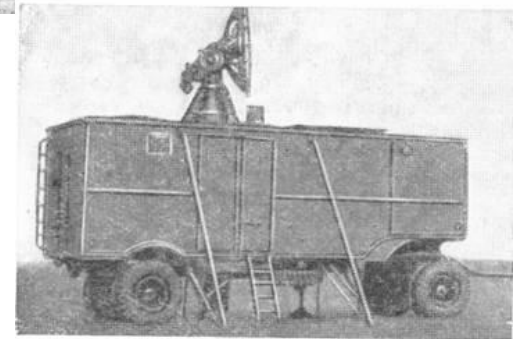
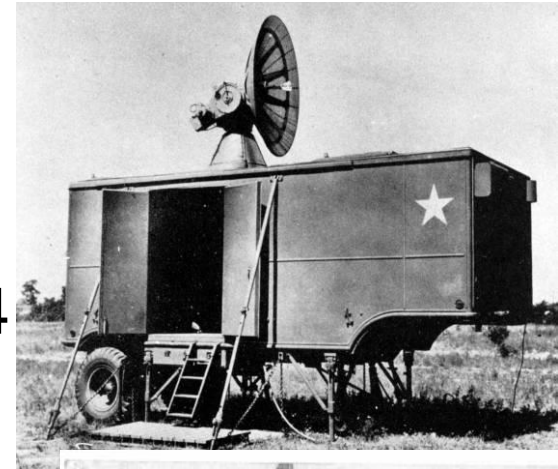

Surface to Air Missiles – Radar

SA-75MK Dvina (SA-2B/F) *Fan Song*

- **Target acquisition radar**
 - P-12 (Spoon Rest-A) the A band (VHF, metric wavelength)



TARGET AIRCRAFT



CONCEPT OF OPERATION

1. DETECTION OF POSITION OF TARGET AIRCRAFT
2. DETECTION OF POSITION OF MISSILE BEACON
3. CALCULATION OF INTERCEPT POINT
4. MISSILE IS COMMAND GUIDED TO IMPACT POINT

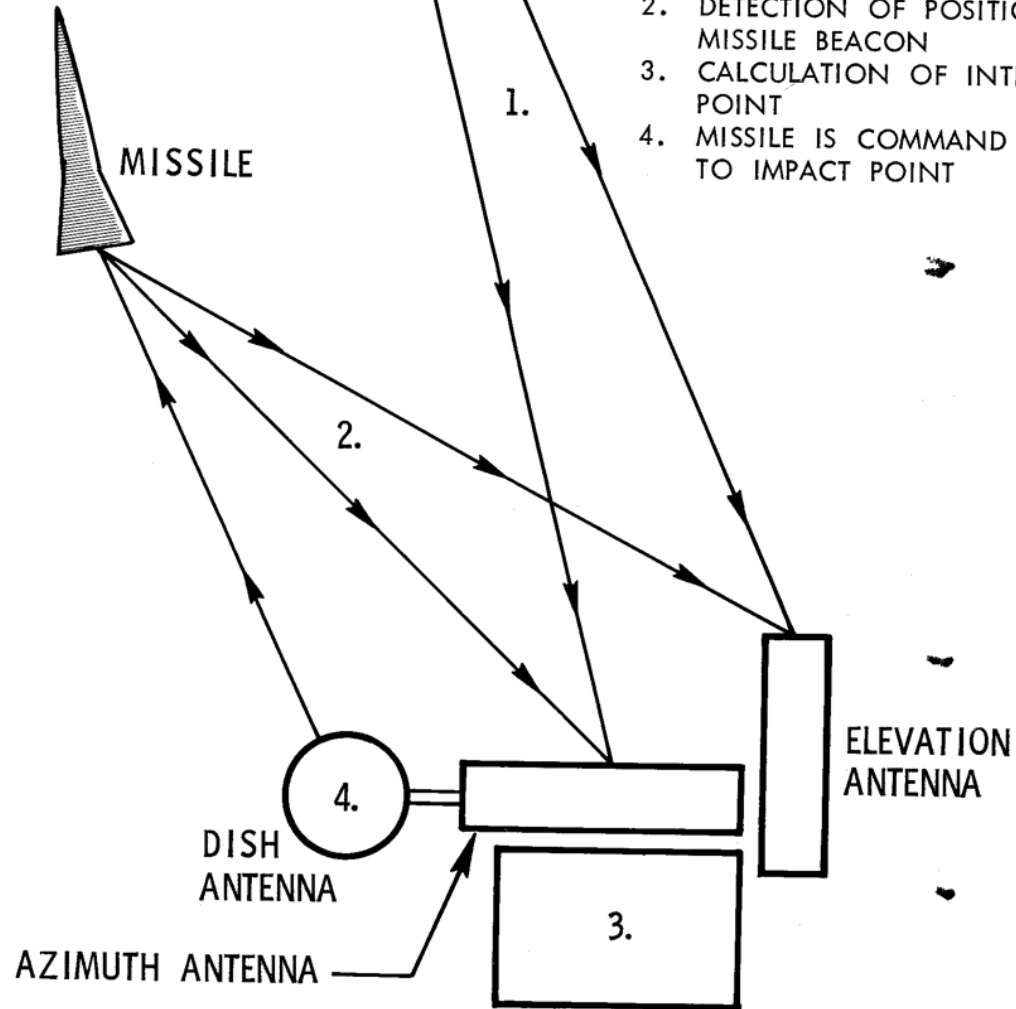

FAN SONG RADAR

AS IT TRACKS BOTH TARGET AND MISSILE

Surface to Air Missiles – Radar

SA-75MK Dvina (SA-2B/F) *Fan Song*

- **SAM control radar RSNA-75M (Fan Song F)**
 - E band (10cm wavelength) with a TWS (Track While Scan) target tracking method
 - used two separate antennas, with two separate frequency.
 - needed to jam both at the same time



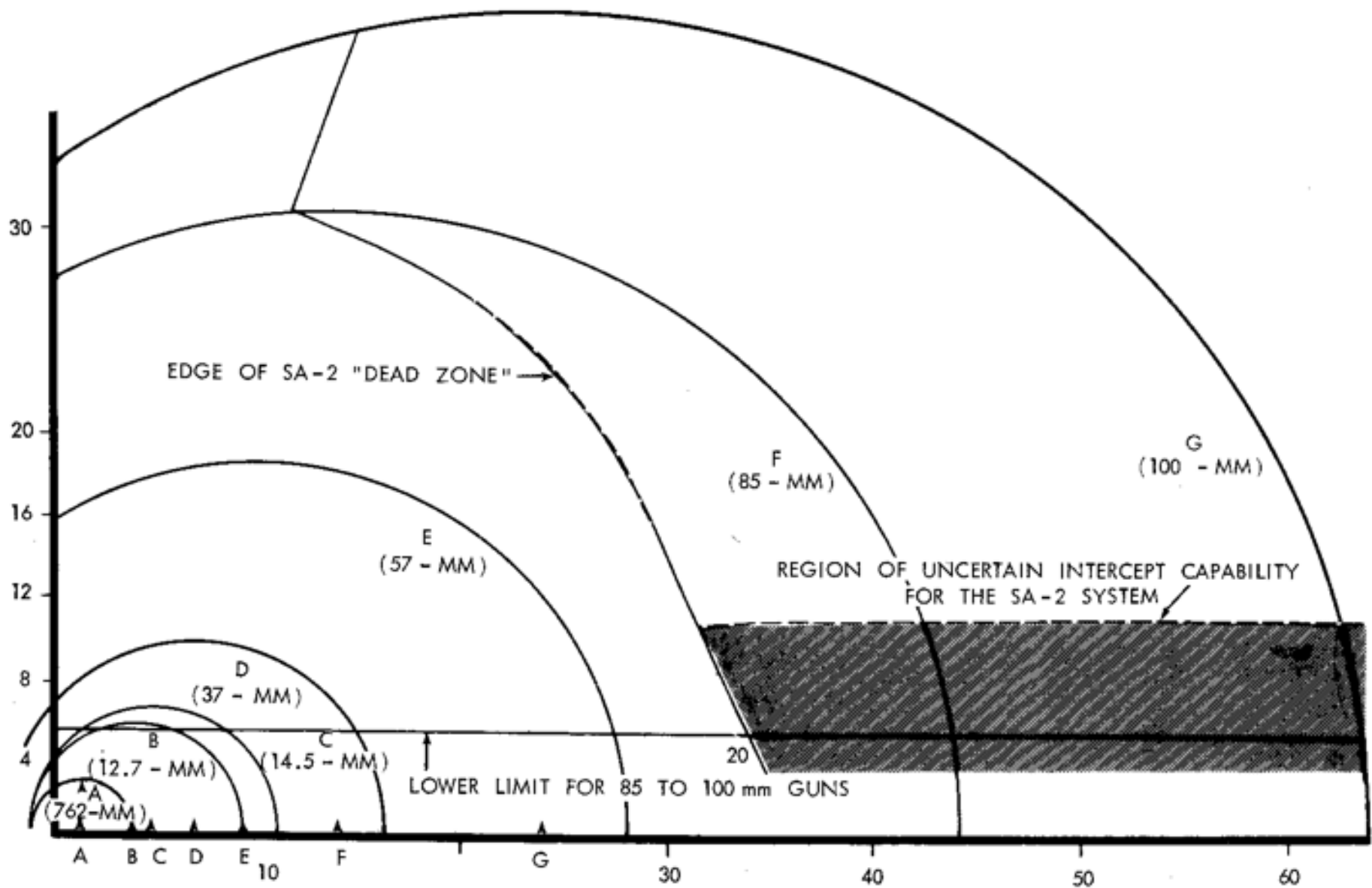

ALTITUDE AND DISTANCE
IN THOUSANDS OF FEET.

AA AND SA-2 EFFECTIVENESS ENVELOPES

Jamming the SA-75MK Dvina (SA-2B/F)

Air Force QRC-160-1 ALQ-71

- jamming pod on the F-4, side mounted on F-105
- E band: 4 voltage tuned magnetrons 100W each
 - FM modulated continuous wave noise jamming
 - jamming frequency range was preset on the ground
 - RAM air turbine
 - Pilot had only an On/Off switch



Jamming the SA-75MK Dvina (SA-2B/F)

Air Force QRC-160-1A ALQ-71

- Added modulated AM Noise Jamming
 - 6th~8th (96~128Hz) harmonic of the fire control radar's scanning frequency (16Hz)
- At the operator scope, this resulted 6~8 vertical noise strobe, per plane
 - In a 4-ship formation, 24~32 vertical noise strobes could completely confuse the operators



Jamming the SA-75MK Dvina (SA-2B/F) Air Force

- Noise jamming created a vertical band on the SAM operator screens, however, a single plane was trackable
 - Missiles could be guided against it with T/T method, using 11sec (arm after launch) radio proxy fuse setting
- F-105, F-4' s used “jamming pod formations to merge the vertical bands on the operator screen, to create one wide band, thus making precise angle tracking impossible



Jamming the SA-75MK Dvina (SA-2B/F) **Beacon Jammer**

- The SA-2 Guideline missile beacon, was in a narrow 20MHz band
- Planes launched w/two QRC-160-1/1A pods, where one pod was solely dedicated for the missile beacon noise jamming
- For several months, all missiles were lost right after launch

Jamming the SON-4 (Whiff) SON-9 (Fire Can) AAA fire control radars

Air Force QRC-160-1

- Barrage Noise Jamming denied the aircraft distance (range) from the radar
 - angles (elevation, azimuth) were still trackable
- Without range information, they were unable to calculate the required firing lead

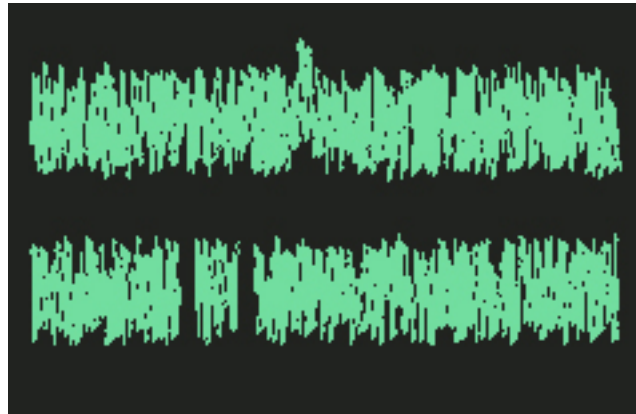



Рис. 91. Принципы применения аппаратуры QRC-160

Jamming the SA-75MK Dvina (SA-2B/F)

Navy ALQ-51 Angle Deception Jamming system

- on the A-4/A-6, F-4/ F-8
- Amplitude Modulation radiated into the side-lobes of the radar, main-lobe untouched
- At the operator screen, resulted in a "mustache" shaped target
- The automatic angle tracking would track the side of the "mustache" (where the target shape is widest) instead of the middle of the target - causing a miss
 - so the target had to be tracked manually

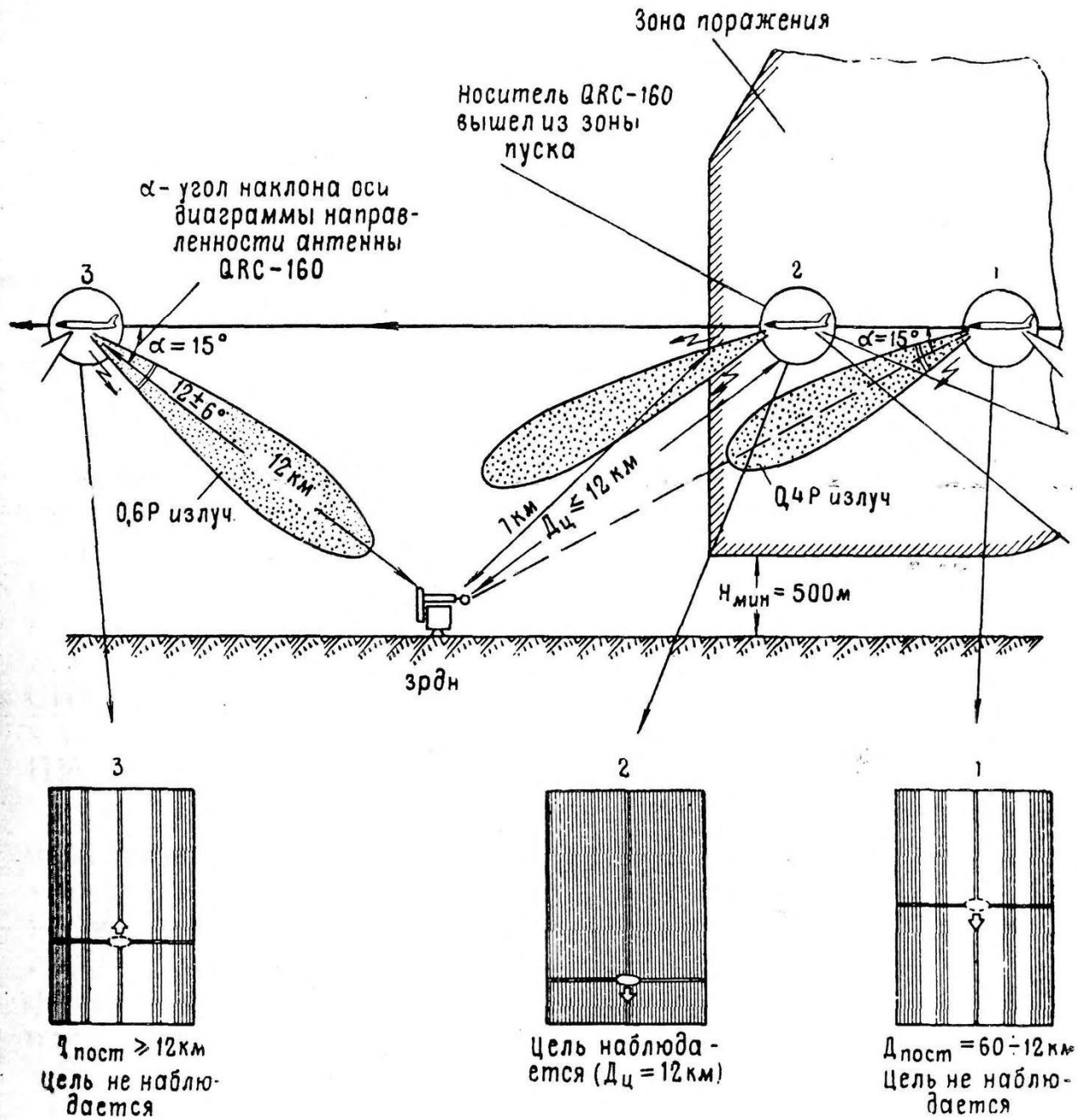

Рис. 12. Вид экрана индикатора оператора РС (масштаб — 5 км) при самоприкрытии пары самолетов А-7 ответной импульсной помехой

Jamming the AAA SON-4 (Whiff) SON-9 (Fire Can) AAA control radar Navy

- ALQ-51 Inverse Gain Jamming system on the A-4/6, F-4/8
- During target tracking, the pencil beam of the antenna is conically scanned around the tracked target, mechanically
- The target tracking system seeks to equalize the received signal strength during the rotation, thus centering the target.
- The stronger jammer signal will lure the radar boresight away the target, eventually breaking its angle lock

Jamming the SA-2B/F Dvina, S-75 Desna (SA-2C), S-75M Volhov (SA-2E) & SON-9 Fire Can

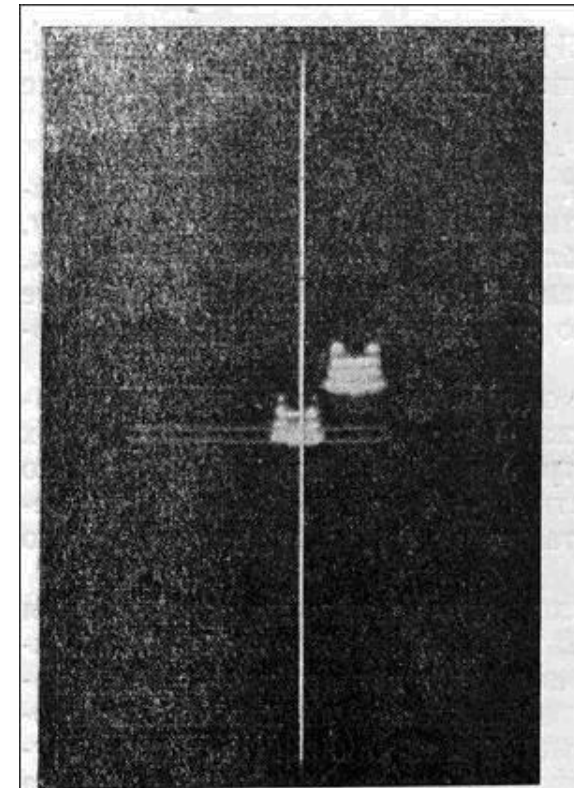
Air Force QRC-160-8, AN/ALQ-87 jamming pod

- Denied range and azimuth data to SON-9 Fire Can
- Denied Fan Song of range, altitude and azimuth
- Jammed the position beacon (downlink) in the SA-2 missile
- sweep modulator, pulse modulated and barrage noise

Magnetron

- E & F band - 2550Mc to 3650Mc - bandwidth 80 to 275Mc
- G & H band - 4910Mc to 5110Mc - bandwidth 25 to 210Mc
- 5350Mc to 5550Mc - bandwidth 25 to 210Mc
- A band (153-157Mhz) noise jammer whenever a Track-While-Scan radar is seen



Jamming the SA-75MK Dvina (SA-2B/F)

Air Force QRC-160-8, AN/ALQ-87 jamming pod

- Mode A - 100W pulse noise 25-100Mhz bandwidth
- Mode B - 300W pulse noise 25-100Mhz bandwidth
- Mode C - 300W pulse noise 80-210Mhz bandwidth
- Mode D - 300W pulse noise 80-210Mhz bandwidth - or barrage noise 80-240mhz/hz



Jamming the S-75 Desna (SA-2C)

S-75M Volhov (SA-2E)

Navy AN/ALQ-49

- G/H band Angle Deception Jamming System
- Complemented the already fielded AN/ALQ-51
- BTW, the S-75M Volhov (SA-2E) never appeared in North Vietnam

Jamming the SA-2B/F Dvina, S-75 Desna (SA-2C), S-75M Volhov (SA- 2E)

Air Force ALQ-101/ 105

- First TWT (Traveling Wave Tube) jammer
- 2.6 to 5.2GHz frequency range
- installed inside of the F-105G Wild Weasel, it was called the AN/ALQ-105



Russian Anti-Jam Mods to the SA-75MK Dvina (SA-2B/F)

- H<1 switch reduced the min altitude to 500m
- RAB.po.K3 switch, in case of radio proxy fuse jamming
- PA-00 cabin "doghouse" at the top of the cabin for visual target tracking, in dense jamming environment
- APP-75M instrument, to make launch calculations automatic
- V-750VK missile beacon output increased from 20W to 80W



Jamming the SA-125 Neva (SA-3)

Air Force QRC-160-2 ALQ-72

- I-band Barrage Noise Jamming pod
- Brought into the the Vietnam War theater, but never flown



Standoff Jamming

Air Force EB-66

- ALT-6B E band Spot Noise Jammer
 - hydraulically tuned magnetron to aim its frequency during flight against a specific SAM site
 - Limitations were, that against one SAM fire control radar, needed to aim two ALT-6B (epsilon/azimuth), and provided protection only if the attacker plane was between the jammer and the site.T
 - AC used the EB-66E aircraft that carried 34pcs.



Standoff Jamming

Air Force EB-66



- High power barrage and tunable jamming
 - 21 ALT-6B - Spot Noise Jammers, in the E band to counter SAMs
 - Limitations were, that against one Dvina fire control radar, you needed to aim exactly two ALT-6B (epsilon/azimuth), and provided protection only if the attacker plane was between the jammer and the site
- In 1967 after the F-105 had their own jammer QRC-160 pod EB-66s were used against early warning and ground controlled intercept radars
 - Flights of three aircraft were used two EB-66Bs and one EB-66C.
 - Up to three of these flights were used to cover a strike mission during target ingress and egress as well as during the actual strike

Standoff Jamming

Air Force EB-66



- EB-66 C-Model ELINT
 - "see" enemy electronic transmissions and then jam
 - Could identify MiG IFF and Fan Song (SAM search and tracking radar) signals, and provide MiG and SAM warnings

Тактико-технические характеристики средств активных помех американской авиации

Тип аппаратуры помех	Диапазон частот, МГц Диапазон волн, см	Число передатчиков	Мощность передатчиков, Вт	Вид помех, режимы работы, ширина спектра	Дополнительные сведения об аппаратуре помех
ALT-32	40—150 750—200	1	100	АШП в прицельном или заградительном режиме; 5—50 МГц	Используется для создания помех РЛС РТВ, средствами радио- и радиорелейной связи. Работает в основном в прицельном по частоте режиме
ALT-32H	150—500 200—60	1	100	АШП в прицельном или заградительном режиме; до 50 МГц	Используется для создания помех РЛС РТВ и средствам радиосвязи. Работает в основном в прицельном по частоте режиме
ALT-31	500—1000 60—30	1	100	АШП в прицельном или заградительном режиме. Ширина спектра неизвестна	Используется, в основном, в заградительном по частоте режиме для подавления РЛС обнаружения РТВ
ALT-22	2500—3500 12—8,56	1	50	АШП в прицельном или скользящем по частоте режиме. Ширина спектра в скользящем по частоте режиме — 6 МГц	Используется для создания помех РЛС РТВ, СНР и СОН. Диапазон перестройки частоты в скользящем режиме: при малой частоте перестройки (2 Гц) — до 150 МГц; при большой частоте перестройки (20 Гц) — до 600 МГц
ALT-28	1000—1400 30—21,4	1	(·)	АШП в прицельном или заградительном по частоте режиме. Имеется специальная программа модуляции; ширина спектра — 25—525 МГц	Используется, в основном, для создания помех СНР в заградительном или прицельном по частоте режиме в зависимости от плотности РЭС в группировке ПВО
ALR-18	8500—10500 3,56—2,8	1	30	АШП в прицельном или в скользящем по частоте режиме; 300—1200 МГц	Используется для создания помех радиолокационным прицелам самолетов типа МиГ. Управление автоматическое или ручное

List of jammers on B-52/EB-66

Jammers on Linebacker II B-52' s

- By Dec ' 72 B52' s had:
 - 4 ALT-28' s reinforce the ALT-22 or in downlink jamming
 - ALT-22 Jammer used against the Fan Song track-while-scan beacon
 - 41 of 98 B52-G models on Guam carried older, less powerful ALT-6' s instead of the ALT-22' s and ALT-28
- EWO' s directed two ALT-28' s and two ALT-22' s or ALT-6' s against Fan Song and used the other pair of ALT-28' s to jam the SAM guidance beacon
- The remaining ALT-22 or ALT-6, usually attacked height-finder radars
- ALT-28 backward wave oscillator

List of ECM on B-52D

Receivers

- AN/ALR-18 automatic receiver
- AN/ALR-20 panoramic receiver
- AN/APR-25 display

Jammers

- 4 AN/ALT-6B or AN/ALT-22 CW jammers
- 2 AN/ALT-16 barrage-jammers.
- 2 AN/ALT-32H high-band jammers.
- 1 AN/ALT-32L low-band jammers
- 6 AN/ALE-20 flare dispensers, with a total of 96 flares.
- 8 AN/ALE-24 chaff dispensers, with a total of 1,125 bundles

Jamming Soviet ABM Systems

Nose cone ejection.

Heating caused by aerodynamic drag when leaving the upper atmosphere after nose cone ejection is known as exit heating.

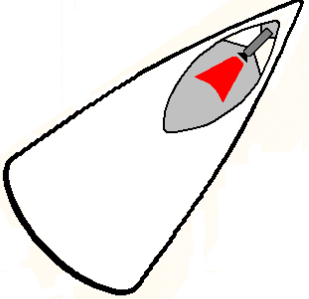

Heat shield to protect against nose cone eject rocket exhaust and exit heating.

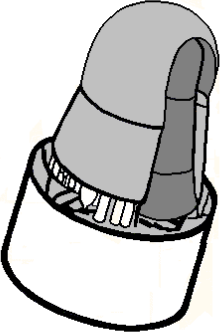

Equipment section and second-stage booster.

Second-stage booster omitted to save space and aid clarity.

Heat shield ejection.

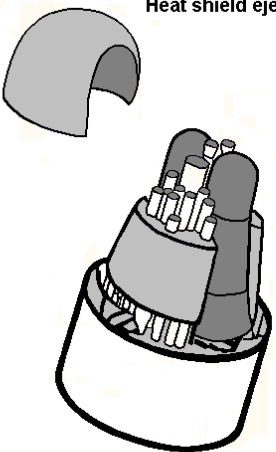

Tilt-out.

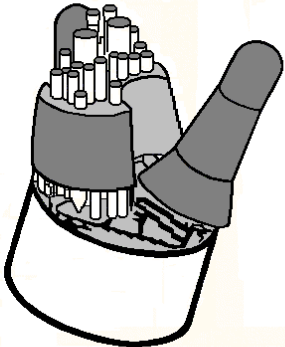

PAC and ReB separation uses solid-fuelled rocket motors.

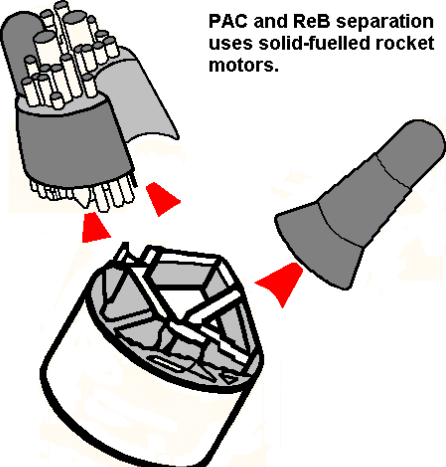

PAC and ReB-P

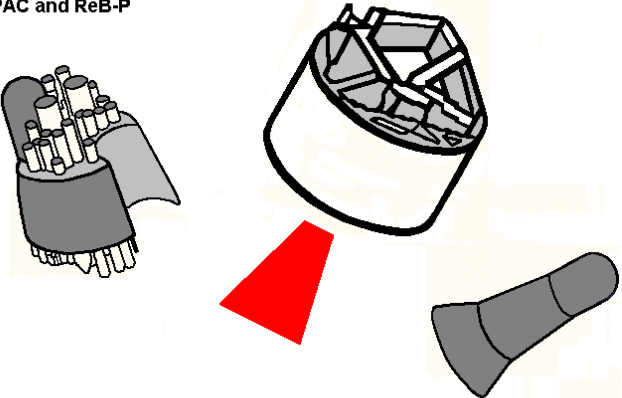

ReB-C

Relieved of PAC and ReB weight, the second-stage booster still firing, accelerates past the PAC and ReB-C.

ReB-P ejected from PAC using solid-fuel rocket motor.

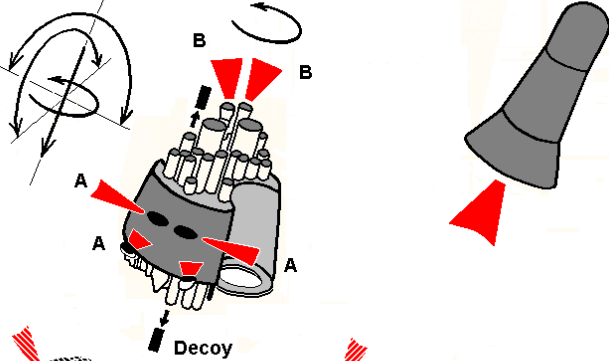

ReB-C

Spent second-stage booster.

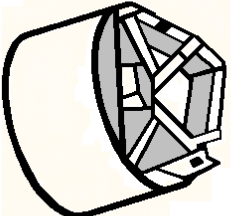

PAC manoeuvres to all attitudes using four intermittent hot-gas jets (A) and moves using liquid-fuel rockets (B) to disperse long and short-throw decoys, spool-chaff and other penails into a pre-determined 'Threat-tube' 150 miles long surrounding the ReBs and warheads, and the ReB 'disguise' deploys to match ReB radar image to the decoys.

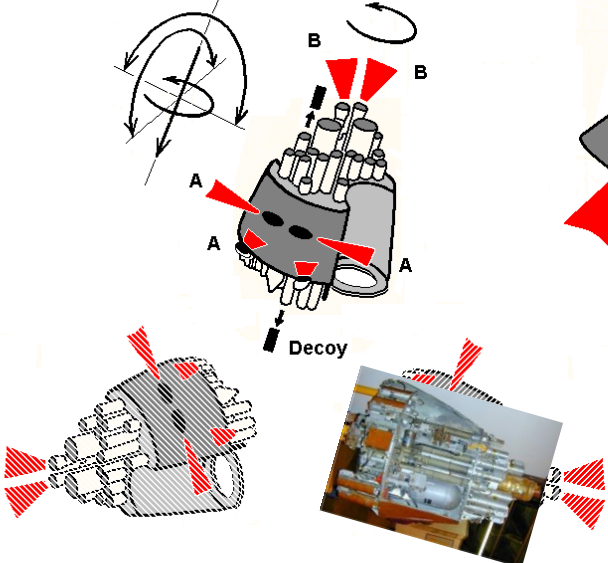

**Story 6: 1956 Why It's *Silicon*
Valley**

Meanwhile, on the Other Side of Town...

The Head of Radar Bombing training for Air Force
starts a Company

The Real Story of Silicon Valley History

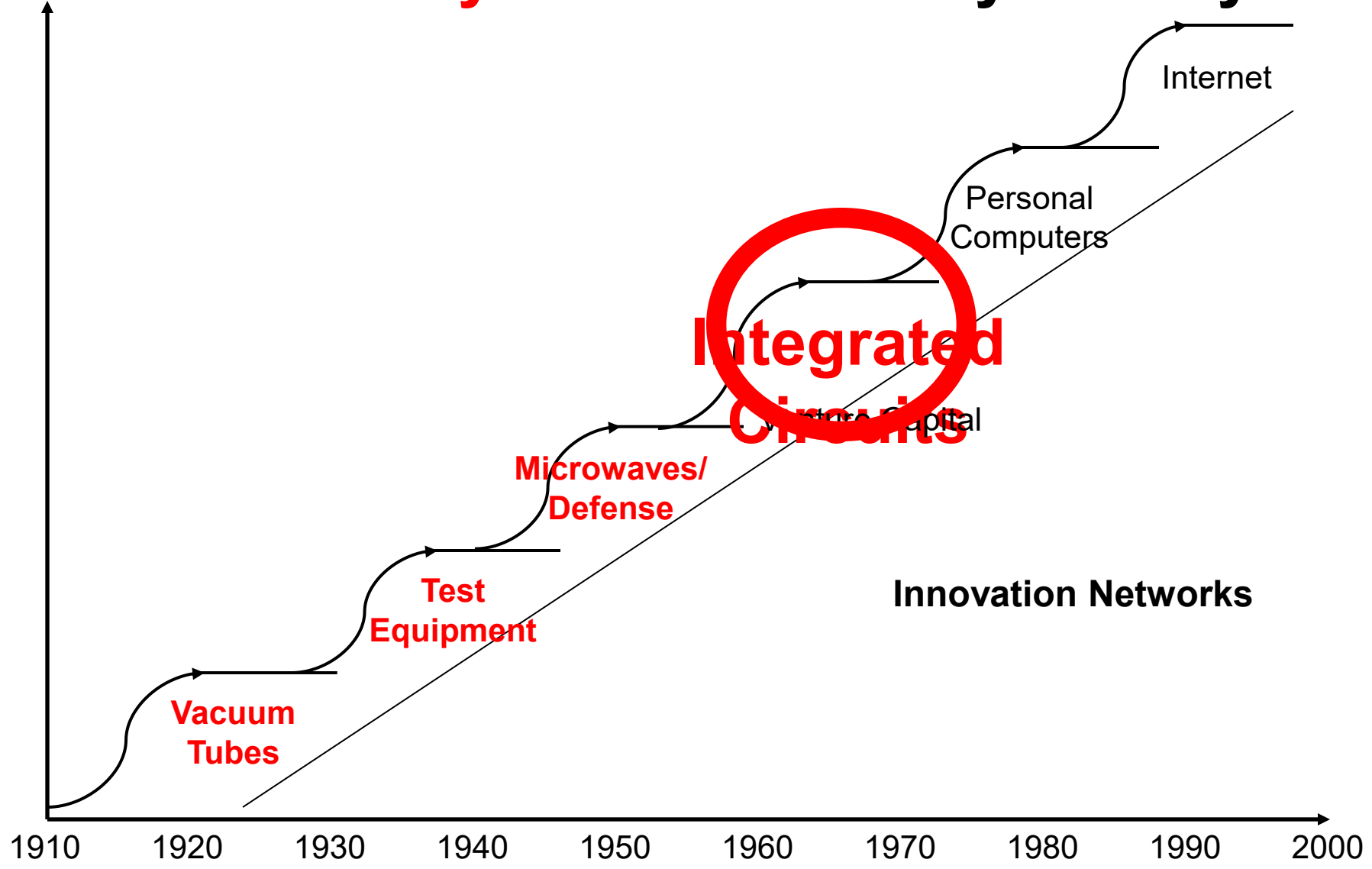

**Integrated
Circuits**

Innovation Networks

1910 1920 1930 1940 1950 1960 1970 1980 1990 2000



William Shockley

“The Other Father of Silicon Valley”

- Director of Navy anti-submarine warfare
- Head of Radar Bombing training for Air Force
- Co-inventor of the transistor
 - Nobel Prize in 1956
- Director of Research DoD Weapons System Engineering Group 1954
- Founded Shockley Semiconductor 1955



William Shockley

Weapons System Engineering Group

- Chief Science Officer
- WSEG reported to the Joint Chiefs of Staff

PRINCIPAL WSEG AND IDA OFFICERS, 1949-1976

Year	Director, WSEG	<u>Director of Research, WSEG</u>	President, IDA
1949	Lt. Gen. John F. Hull, USA (January)	Philip M. Morse (March)	
1950		Howard P. Robertson (June)	
1951	Lt. Gen. Geoffrey Keyes, USA (February)	E. Bright Wilson (July)	
1952			
1953			
1954	Lt. Gen. S. E. Anderson, USAF (August)	William B. Shockley (July)	
1955		Albert G. Hill (December) (Vice President and Director of Research, IDA, from April 1956)	
1956		Maj. Gen. James McCormack, Jr., USAF (Ret.) (April)	
1957	Vice Adm. J. H. Sides, USN (August)		



William Shockley

Shockley Transistor Corporation

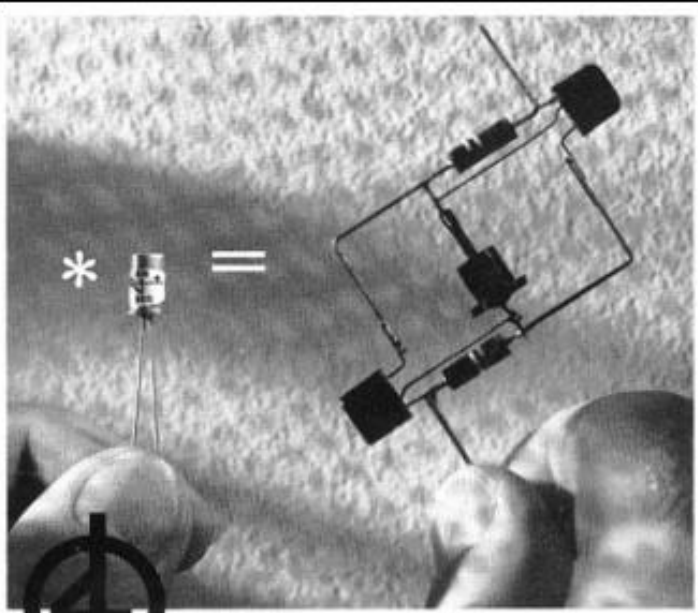

SHOCKLEY 4-LAYER TRANSISTOR DIODE*
SIMPLIFIES SWITCHING CIRCUITRY FOR
COMPUTERS, TELEPHONY, CONTROL

HERE'S HOW

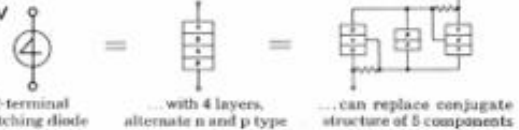

2-terminal switching diode ...with 4 layers, alternate n and p type ...can replace conjugate structure of 5 components

ENGINEERING DATA AND ASSISTANCE

Our engineering staff, under the direction of Dr. William Shockley, will undertake circuit problems in typical applications such as: sawtooth oscillators, pulse generators, bistable circuits, ring counters and various switching functions. Special types of transistor diodes are being developed to individual specifications. Technical information on request. Write to Dept. 1A-718.
*Patented at Bell Telephone Laboratories.

Shockley Transistor Corporation
 1117 California Avenue, Palo Alto, Calif.
 A SUBSIDIARY OF BECKMAN INSTRUMENTS, INC.





William Shockley

“The Other Father of Silicon Valley”

- Director of Navy anti-submarine warfare operations group at Columbia (1942-1943)
- Head of Radar Bombing training for Air Force (1943-1945)
- Deputy Director and Research Director of the Weapons System Evaluation Group in the Defense Department (1954-1955)
- Co-inventor of the transistor
 - Nobel Prize in 1956
- Founded Shockley Transistor 1955
 - First semiconductor company in California

William Shockley

“Great Researcher, Awesome Talent Spotter, Horrible Manager”



- Unintended consequences:
 - “The traitorous 8” leave Shockley
 - found Fairchild Semiconductor
 - 1st VC-backed startup
 - Noyce & Moore leave Fairchild to start Intel
 - **65 other chip companies** in the next 20 years
- Eugenics beliefs end his career 1963

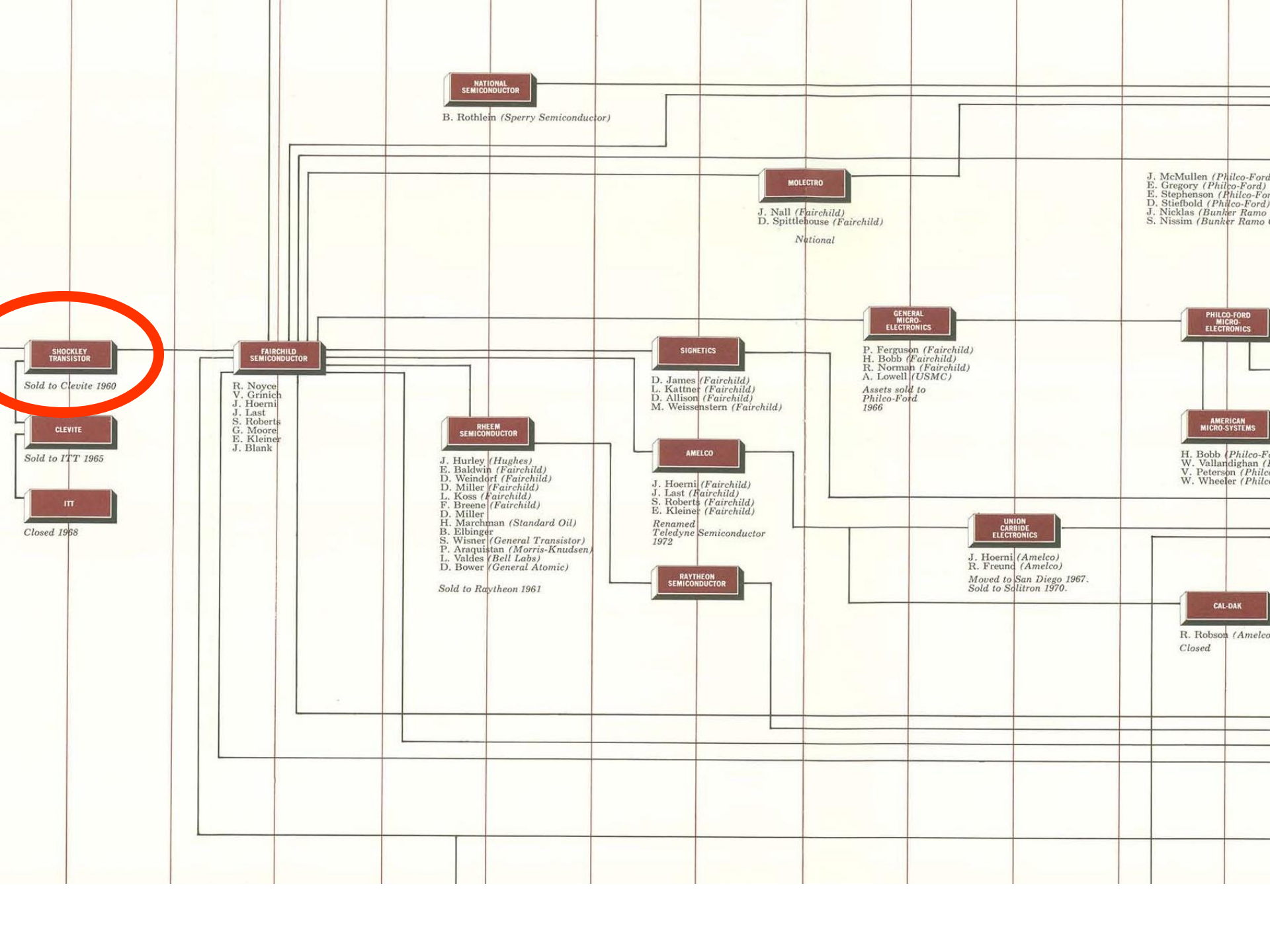

NATIONAL SEMICONDUCTOR

B. Rothlem (*Sperry Semiconductor*)

MOLECTRO

J. Nall (*Fairchild*)
D. Spittlehouse (*Fairchild*)
National

J. McMullen (*Philco-Ford*)
E. Gregory (*Philco-Ford*)
E. Stephenson (*Philco-Ford*)
D. Stiefbold (*Philco-Ford*)
J. Nicklas (*Bunker Ramo*)
S. Nissim (*Bunker Ramo*)

GENERAL MICRO-ELECTRONICS

P. Ferguson (*Fairchild*)
H. Bobb (*Fairchild*)
R. Norman (*Fairchild*)
A. Lowell (*USMC*)
Assets sold to Philco-Ford 1966

PHILCO-FORD MICRO-ELECTRONICS

AMERICAN MICRO-SYSTEMS

H. Bobb (*Philco-Ford*)
W. Vallandigham (*Philco-Ford*)
V. Peterson (*Philco-Ford*)
W. Wheeler (*Philco-Ford*)

FAIRCHILD SEMICONDUCTOR

R. Noyce
V. Grinich
J. Hoerni
J. Last
S. Roberts
G. Moore
E. Kleiner
J. Blank

SHOCKLEY TRANSISTOR

Sold to Clevite 1960

CLEVITE

Sold to ITT 1965

ITT

Closed 1968

RHEEM SEMICONDUCTOR

J. Hurley (*Hughes*)
E. Baldwin (*Fairchild*)
D. Weindorf (*Fairchild*)
D. Miller (*Fairchild*)
L. Koss (*Fairchild*)
F. Brene (*Fairchild*)
D. Miller
H. Marchman (*Standard Oil*)
B. Elbinger
S. Wisner (*General Transistor*)
P. Araquistain (*Morris-Knudsen*)
L. Valdes (*Bell Labs*)
D. Bower (*General Atomic*)

Sold to Raytheon 1961

SIGNETICS

D. James (*Fairchild*)
L. Kattner (*Fairchild*)
D. Allison (*Fairchild*)
M. Weissenstem (*Fairchild*)

AMELCO

J. Hoerni (*Fairchild*)
J. Last (*Fairchild*)
S. Roberts (*Fairchild*)
E. Kleiner (*Fairchild*)

Renamed Teledyne Semiconductor 1972

RAYTHEON SEMICONDUCTOR

UNION CARBIDE ELECTRONICS

J. Hoerni (*Amelco*)
R. Freund (*Amelco*)
Moved to San Diego 1967. Sold to Solitron 1970.

CAL-DAK

R. Robson (*Amelco*)
Closed

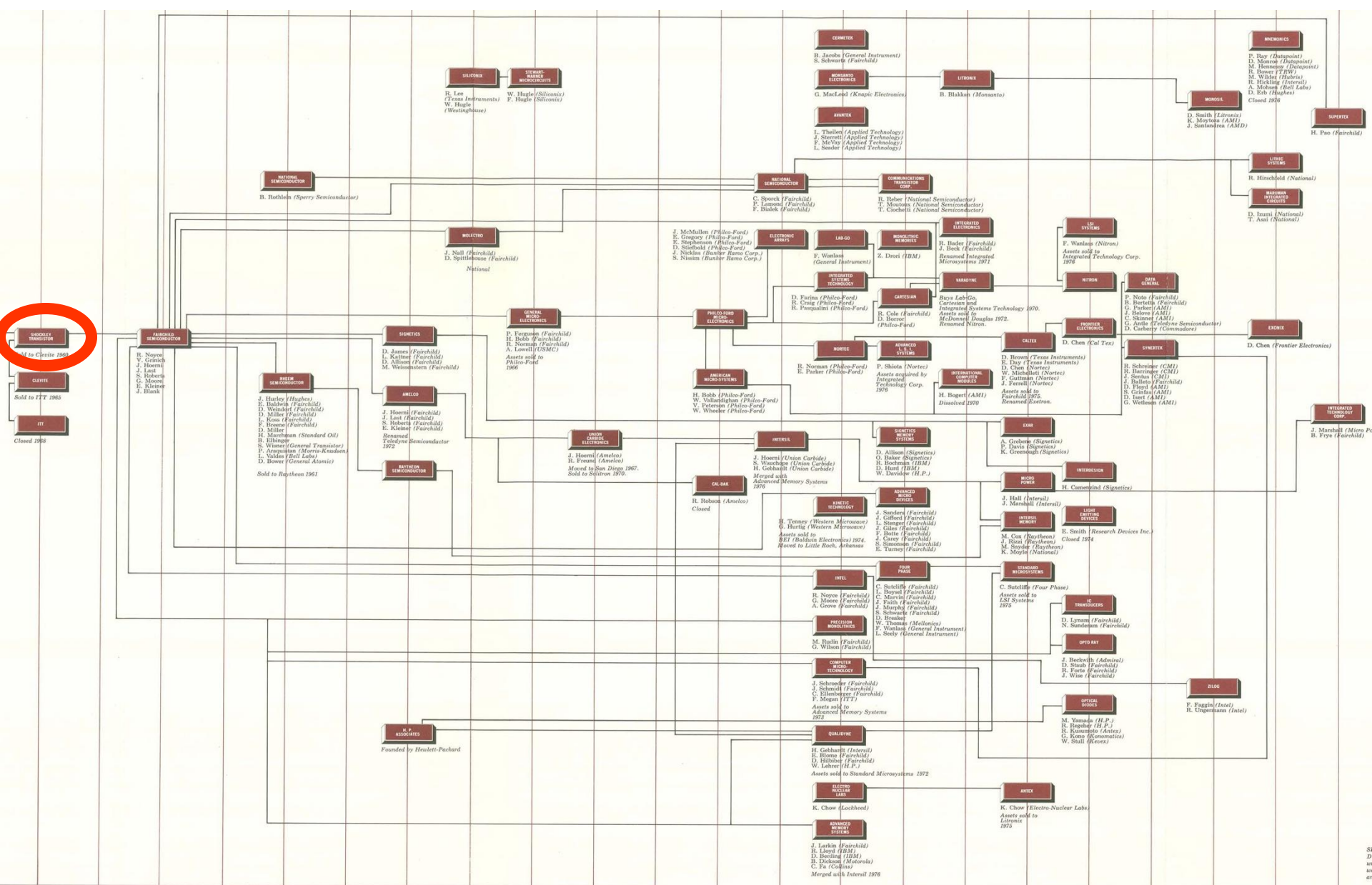

Semiconductor Genealogy: 1955 - 1976

Shockley's Legacy



- It's *Silicon* Valley

Story 7: Why We All Don't Work for the Government

The Rise of *Private* Capital

Venture Capital Silicon Valley's 2nd Wave

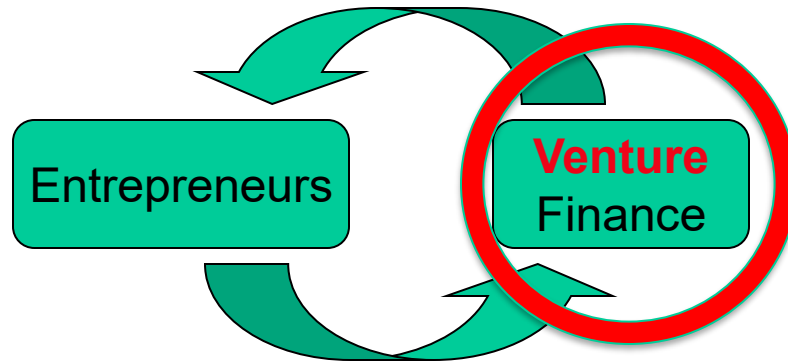

Motivation

Crisis

Profit

Mgmt Tools

Customer
Development

Agile
Development

Business Model
Design

Design
Thinking

Culture

Risk Taking

Entrepreneurial

**Outward-Facing
Tech Universities**

**Free flow of
People/Info**

Infrastructure

**Research
Universities**

**Predictable
Economic System**

**Stable
Legal System**

24/7 Utilities

Venture Capital

Silicon Valley's 2nd Engine of Entrepreneurship

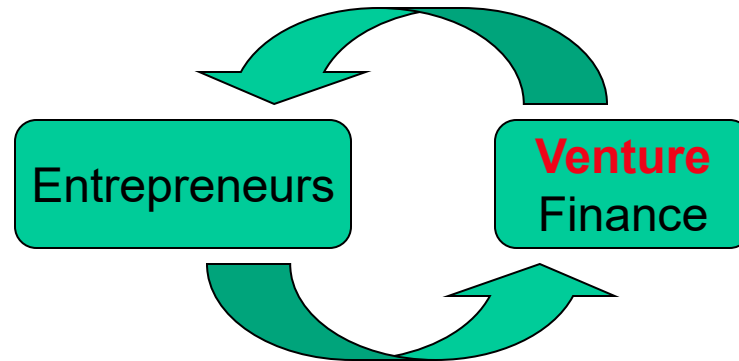

Motivation



Culture

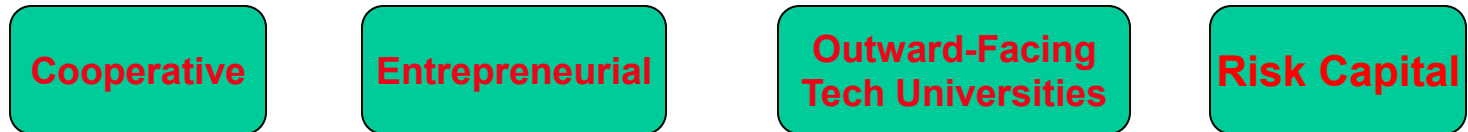

Free flow of
People/Information

Infrastructure

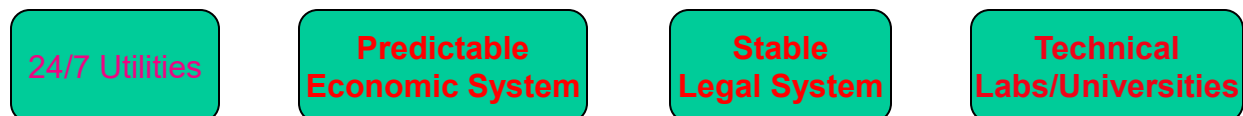

The Valley Attracts Financial Attention

- 1956 **The 1st West Coast IPO's**



- 1957 Hewlett Packard **VARIAN**

- 1958 Ampex



The Rise of Risk Capital

Family Money 1940's - 1960's

- J.H. Whitney
 - 1st family office 1946
- Laurance Rockefeller
 - Draper Gaither & Anderson (1st limited Partnership) 1958
 - Spun out as Venrock in 1969
- Bessemer
- East Coast focus
- Wide variety of industries

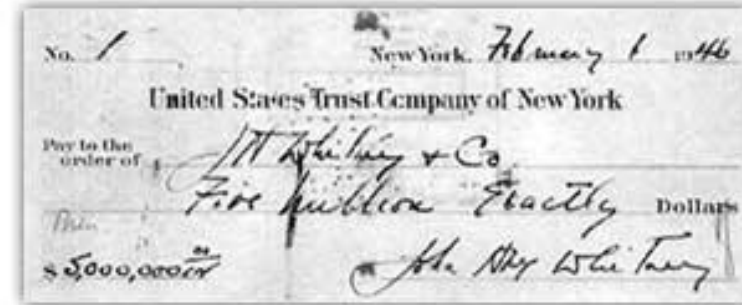

The Rise of Risk Capital

East Coast VC Experiments

- 1946 American Research & Development
 - George Doriot
 - Right idea, wrong model
(public VC firm)
- 1963 Boston Capital



The Rise of Risk Capital

“The Group” 1950’s

- First Bay Area “Angels”
 - Reid Dennis
 - William Bryan
 - William Edwards
 - William K. Bowes
 - Daniel McGanney

~ 10 deals \$75 -\$300K



Reid Dennis Remembers



- “The first 25 electronics companies required to have a minimum amount of capital of \$300k each and private individuals formed the basis of the early syndicates”
- “...in 1975, prior to the relaxation of ERISA laws, the entire VC industry raised \$10m”

The Rise of Risk Capital

SBIC Act of 1958



- 700 SBIC funds by 1965
 - 75% of all VC funding in 1968, 7% in 1988
- Corporate
 - Bank of America - George Quist, Tom Clauson
 - Firemans Fund/American Express - Reid Dennis
- Private
 - 1959 Continental Capital - Frank Chambers
 - The Group; Bryan Edwards, McGanney
 - 1962 Pitch Johnson & Bill Draper
 - 1962 Sutter Hill

Defense R&D Budget

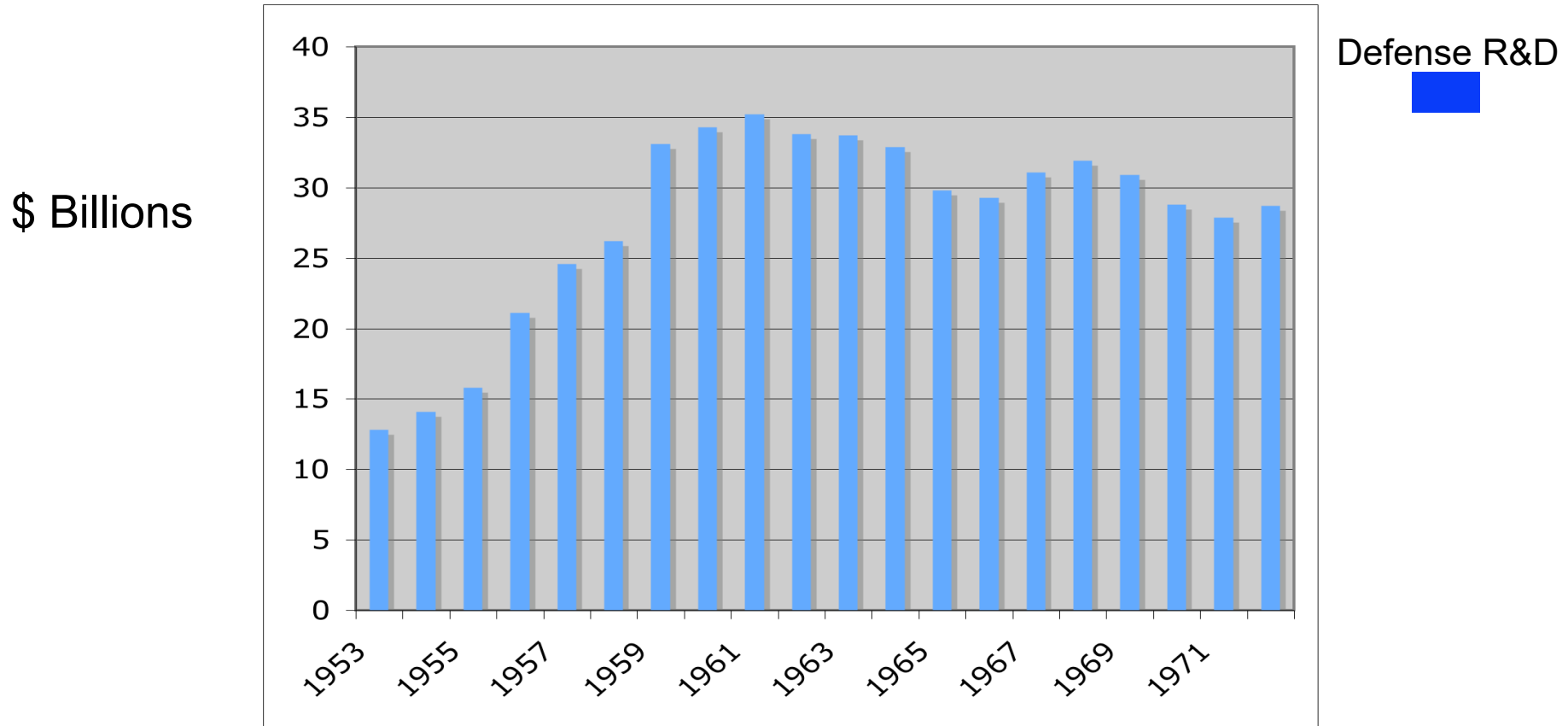

Sources: United States National Science Foundation Science and Engineering Indicators 2006, 2006, <http://www.nsf.gov/statistics/seind06/append/c4/at04-03.pdf>; United States Government, Budget for FY 05, Historical Tables, 2004, Table 9.7, <http://www.gpoaccess.gov/-usbudget/fy05/hist.html>

Defense R&D Budget *California*

\$ Billions

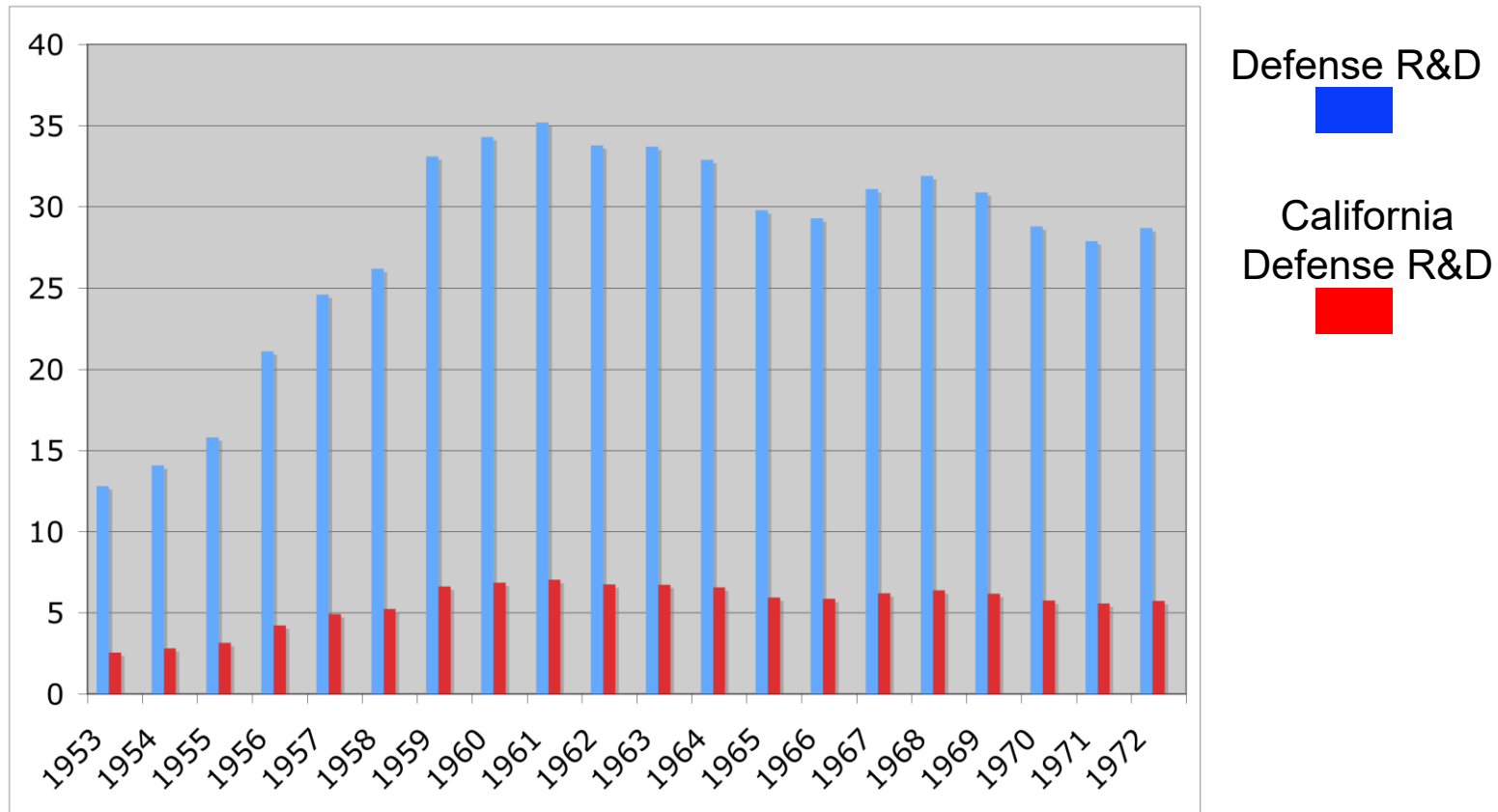

Sources: United States National Science Foundation Science and Engineering Indicators 2006, 2006, <http://www.nsf.gov/statistics/seind06/append/c4/at04-03.pdf>; United States Government, Budget for FY 05, Historical Tables, 2004, Table 9.7, <http://www.gpoaccess.gov/usbudget/fy05/hist.html>

Defense R&D Budget

Silicon Valley

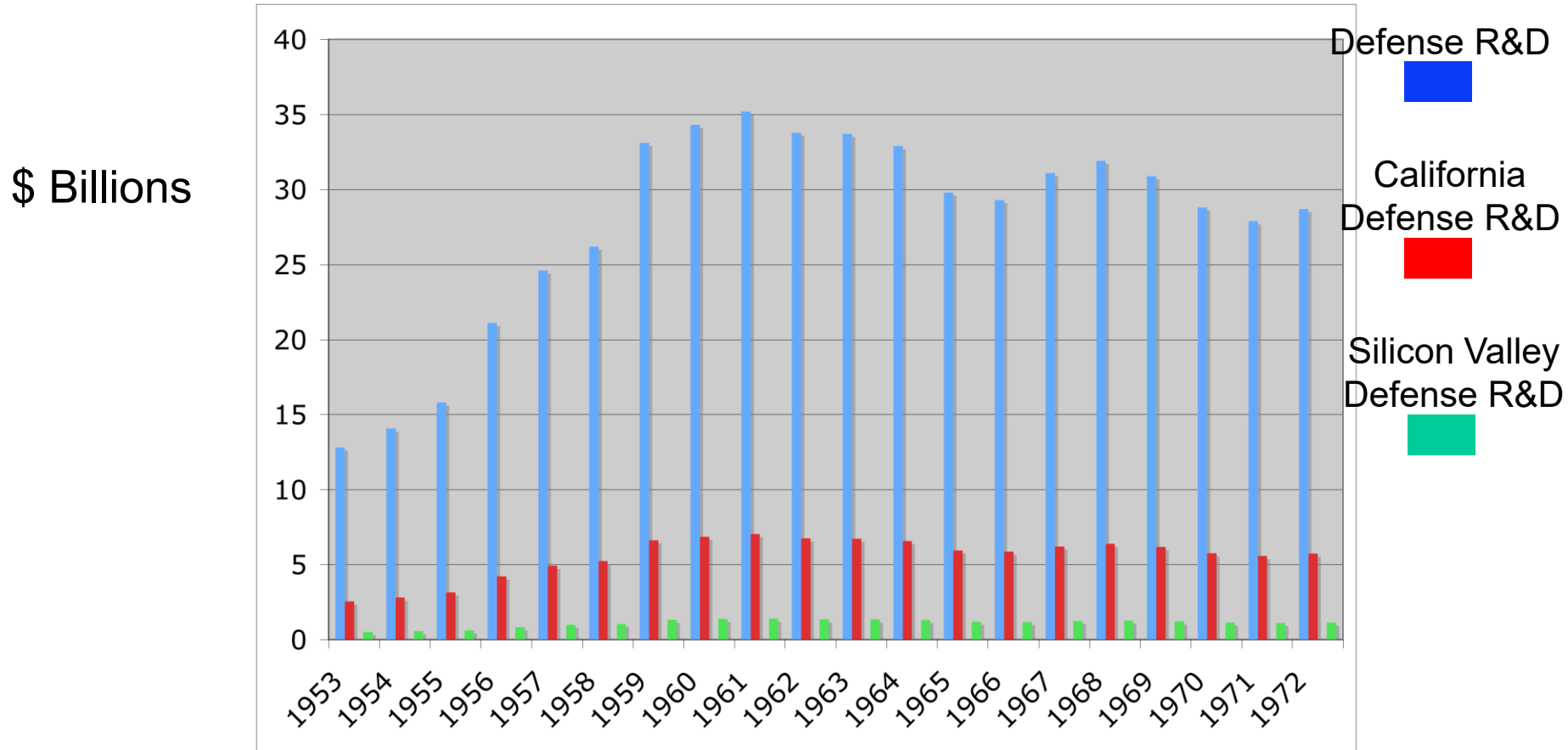

Sources: United States National Science Foundation Science and Engineering Indicators 2006, 2006, <http://www.nsf.gov/statistics/seind06/append/c4/at04-03.pdf>; United States Government, Budget for FY 05, Historical Tables, 2004, Table 9.7, <http://www.gpoaccess.gov/-usbudget/fy05/hist.html>

Defense R&D Budget *Versus Venture Capital*

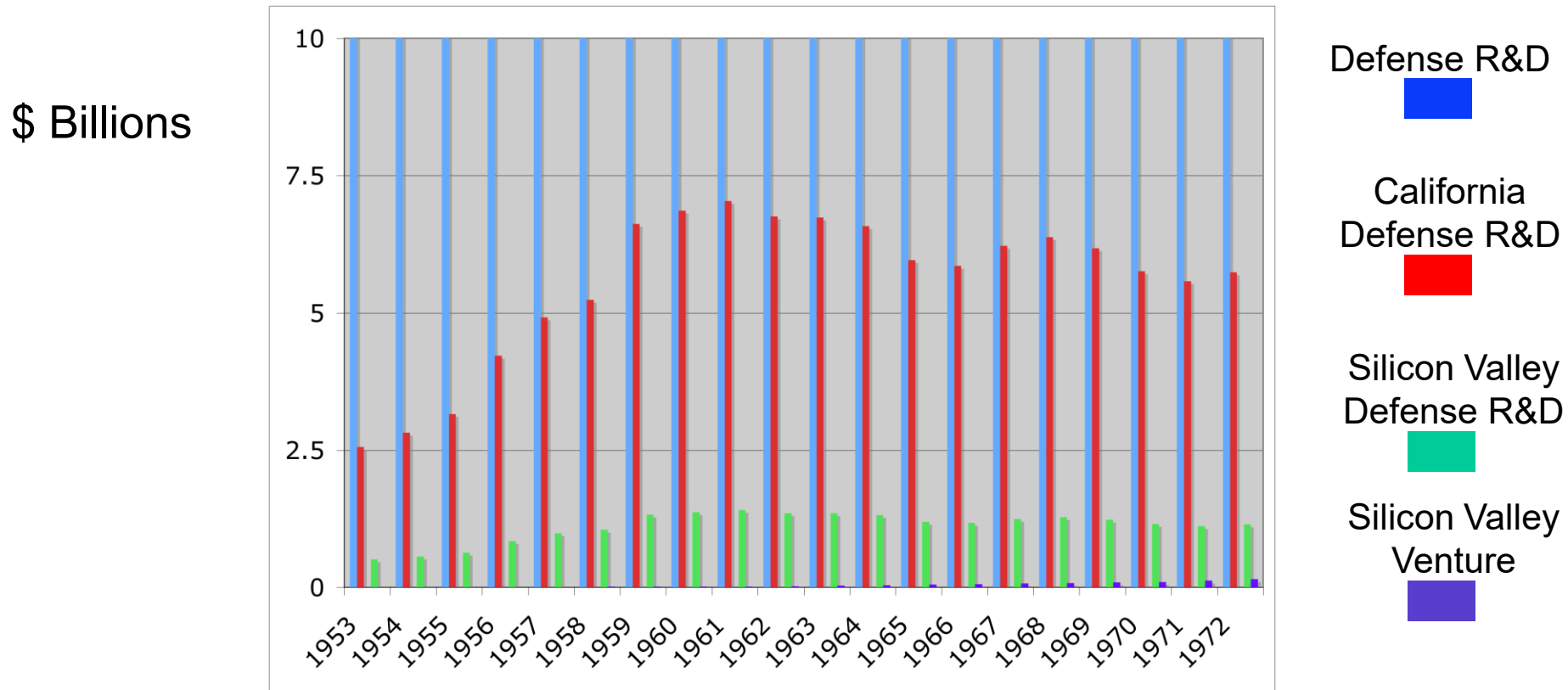

Sources: United States National Science Foundation Science and Engineering Indicators 2006, 2006, <http://www.nsf.gov/statistics/seind06/append/c4/at04-03.pdf>; United States Government, Budget for FY 05, Historical Tables, 2004, Table 9.7, <http://www.gpoaccess.gov/-usbudget/fy05/hist.html>

Defense R&D Budget *Versus Venture Capital*

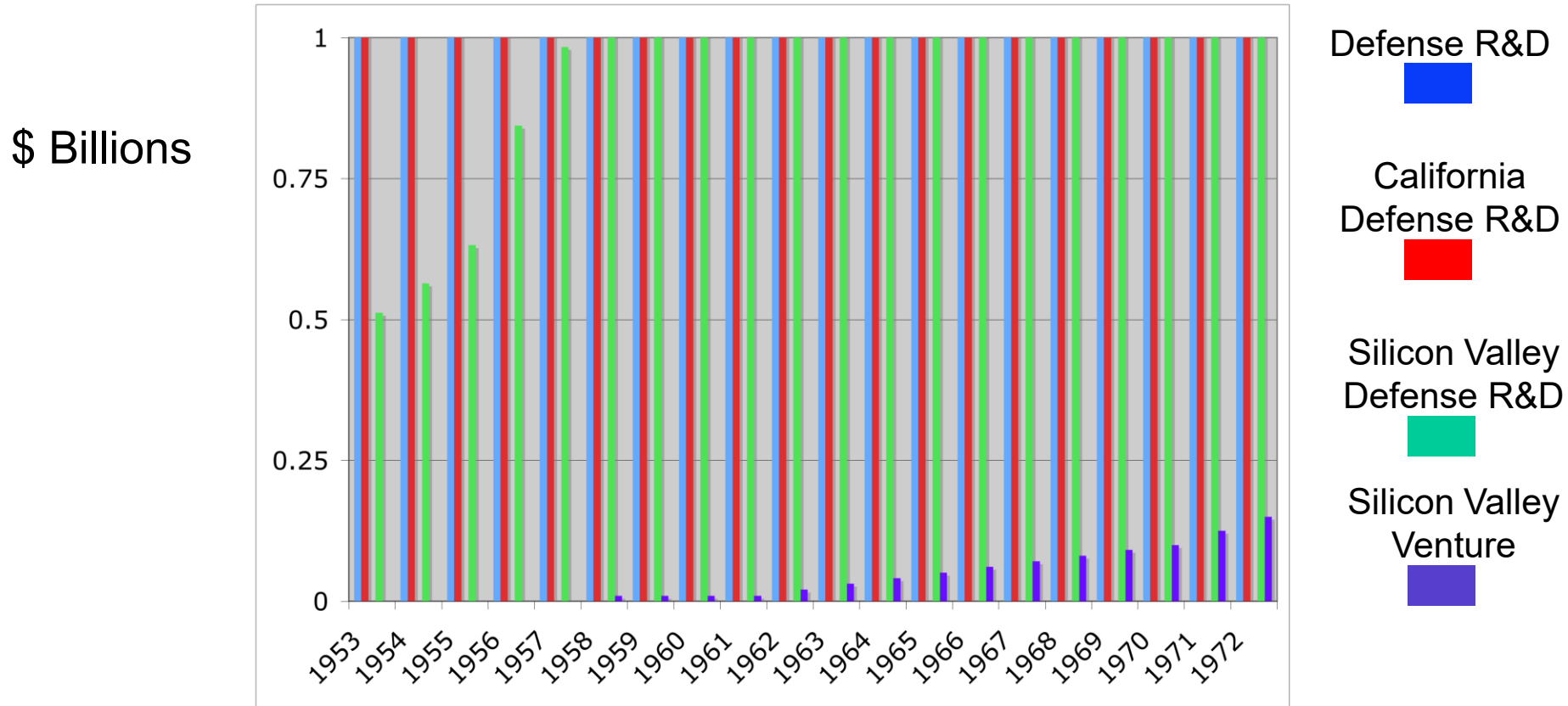

Sources: United States National Science Foundation Science and Engineering Indicators 2006, 2006, <http://www.nsf.gov/statistics/seind06/append/c4/at04-03.pdf>; United States Government, Budget for FY 05, Historical Tables, 2004, Table 9.7, <http://www.gpoaccess.gov/-usbudget/fy05/hist.html>

The Rise of Venture Capital

The Limited Partnership

- Raise money from pension funds, private universities, wealthy individuals – the *limited partners*
- Investment professionals manage the fund – the *general partners* i.e. the VC' s
 - Compensate the general partners via the “2 and 20”
 - 2% management fee, 20% carried interest (i.e. of the profits)

•_Draper Gaither & Anderson	1958
• Rock and Davis	1961
• Sutter Hill	1964
• Patricof & Co.	1969
• Kleiner Perkins	1972
• Sequoia Capital	1972

The Rise of Risk Capital

The Limited Partnership

- DGA (Draper Gaither & Anderson) 1958
- Rock and Davis 1961
- Sutter Hill 1964
- TA Associates 1968
- Mayfield Fund 1969
- Patricof & Co. 1969
- Kleiner Perkins 1972
- Capital Mgmt Services (Sequoia) 1972

The Rise of Risk Capital

1978/1979 - A Watershed

- Capital gains slashed (1978)
 - 49.5% to 28%
- Employee Retirement Income Security Act (1979)
 - Pension funds can invest

Venture Capital

Silicon Valley's 2nd Wave

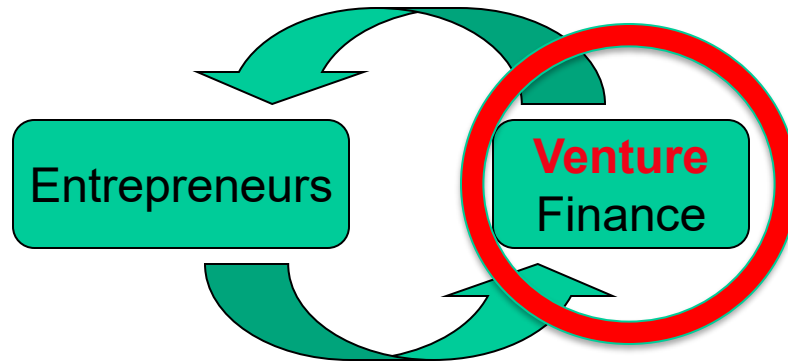

Motivation

Crisis

Profit

Mgmt Tools

Customer
Development

Agile
Development

Business Model
Design

Culture

Risk Taking

Entrepreneurial

Outward-Facing
Tech Universities

Free flow of
People/Info

Infrastructure

Research
Universities

Predictable
Economic System

Stable
Legal System

24/7 Utilities

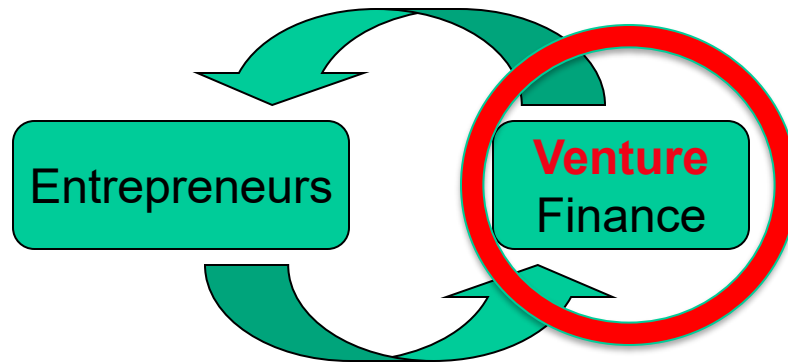

Motivation

Crisis

Profit

Mgmt Tools

Customer Development

Agile Development

Business Model Design

Culture

Risk Taking

Creative

Outward-Facing Tech Universities

Free flow of People/Info

Freedom to Dissent

Infrastructure

Research Universities

Predictable Economic System

Liquidity

Stable Legal System

24/7 Utilities

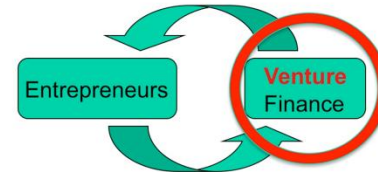
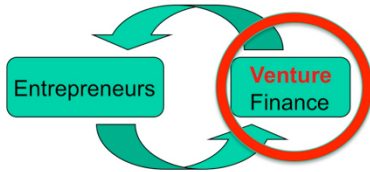

Motivation



Motivation



Mgmt Tools



Mgmt Tools



Culture



Culture



Infrastructure



Infrastructure



Venture Capital

Silicon Valley's 2nd Engine of Entrepreneurship

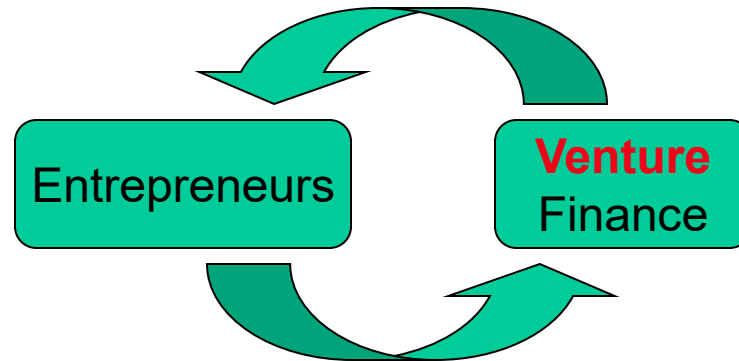

Motivation



Culture



Free flow of
People/Information

Infrastructure

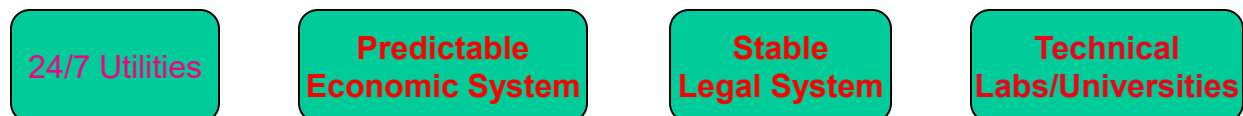

Summary

- Terman/Stanford/Government responsible for entrepreneurial culture of Silicon Valley
- Military primed the pump *as a customer* for key Valley technologies
 - Semiconductors, computers, Internet
 - But very little technical cross pollination
- Venture Capital turned the valley to volume corporate and consumer applications
- Berkeley continued its focus on Big Science and National Labs

Summary

- Terman/Stanford/Government responsible for entrepreneurial culture of Silicon Valley
- Military primed the pump *as a customer* for key technologies
 - Semiconductors, computers, Internet
 - But very little technical cross pollination
- Venture Capital turned the valley to volume corporate and consumer applications

Is there another “crisis” that will restart the valley’s cycle of innovation?

Or will we continue to be profit driven?

WWII Sources - Books

- WWII
 - A Radar History of WWII - Louis Brown
 - Confound and Destroy - Martin Streetly
 - Echoes of War, the Story of H2S Radar - Sir Bernard Lovell
 - The Invention that Changed the World - Robert Buderl
 - Wizard War, British Scientific Intelligence - R.V. Jones
 - History of Air Intercept Radar and British Nightfighter - Ian White
 - The Luftwaffe Over Germany: Defense of the Reich - Donald Caldwell
 - Instruments of Darkness: The History of Electronic Warfare - Alfred Price
 - Volume I: The History of US. Electronic Warfare to 1946 - Alfred Price

Cold War Sources - Books

- Cold War

- Volume II: The History of US. Electronic Warfare: Renaissance Years- Alfred Price
- The Wizards of Langley - Jeffrey T. Richelson
- Body of Secrets: Anatomy of the Ultra-Secret National Security Agency - James Bamford
- The Puzzle Palace: Inside the NSA, - James Bamford
- Secrets of Signals Intelligence During the Cold War and Beyond - Matthew M. Aid, Cees Wiebes
- Eternal Vigilance? - Jeffreys-Jones, Rhodri Jeffreys-Jones, Christopher M. Andrew
- High-Cold-War-Strategic Air Reconnaissance and the Electronic Intelligence War - Robert Jackson
- By Any Means Necessary: America's Secret Air War in the Cold War - William E. Burrows
- Shadow Flights: America's Secret Airwar Against the Soviet Union: A Cold War History - C. Peebles
- Spyplane - Norman Polmar
- Radar Handbook, - Merrill I. Skolnik
- Out From Behind the Eight Ball: A History of Project Echo by Doanld C. Elder

Silicon Valley Sources - Books

- Terman/Shockley/Intel
 - Fred Terman at Stanford - Stewart Gilmore
 - Broken Genius: The Rise and Fall of William Shockley- Joel Shurkin
 - The Man Behind the Microchip: Robert Noyce - Leslie Berlin
- Silicon Valley History
 - Electronics in the West: the First Fifty Years - Jane Morgan
 - The Origins of the Electronics Industry on the Pacific Coast- Arthur Norberg
 - Creating the Cold War University: The Transformation of Stanford - Rebecca S. Lowen
 - The Cold War and American Science: The Military-Industrial-Academic Complex at MIT and Stanford - Stuart W. Leslie
 - Making Silicon Valley: Innovation & the Growth of High Tech - C. Lecuyer
 - Regional Advantage: Culture and Competition in Silicon Valley and Route 128 - Annalee Saxenian
- Venture Capital
 - Creative Capital: Georges Doriot and the Birth of Venture Capital - Spencer E. Ante
- Semiconductor Timeline to 1976: Semi and Don C. Hoefler

ELINT Sources - Web

- Engineering/ELINT in the CIA/NSA
 - <http://www.tbp.org/pages/Publications/Bent/Features/F99Poteat.pdf>
 - <http://www.gwu.edu/~nsarchiv/NSAEBB/NSAEBB54/>
 - <http://www.gwu.edu/~nsarchiv/NSAEBB/NSAEBB54/st06.pdf>
 - <http://www.gwu.edu/~nsarchiv/NSAEBB/NSAEBB54/st08.pdf>
 - <http://www.gwu.edu/~nsarchiv/NSAEBB/NSAEBB60/abm022.pdf>
 - <https://www.cia.gov/library/center-for-the-study-of-intelligence/kent-csi/pdf/v11i2a05p.pdf>
 - <https://www.cia.gov/library/center-for-the-study-of-intelligence/kent-csi/pdf/v12i2a02p.pdf>
 - <https://www.cia.gov/library/center-for-the-study-of-intelligence/csi-publications/books-and-monographs/a-12/hiding-oxcart-in-plain-sight.html>
 - <http://jya.com/nsa-elint.htm>
 - <http://fas.org/irp/program/list.htm>
- ELINT Aircraft Losses
 - <http://www.rb-29.net/HTML/77ColdWarStory/08.01apndxC.htm>
 - <http://www.history.navy.mil/avh-1910/APP34.PDF>

Photo and Movie Sources - Web

- B-24 Ferret ELINT equipment photos
 - <http://aafradio.org/>
- WWII Radar History/Photos/Radar Order of Battle
 - www.gyges.dk
 - <http://www.luftarchiv.de/>
 - <http://www.vectorsite.net/ttwiz.html> The Wizard War
 - http://www.museumwaalsdorp.nl/en/german_radar.html
 - <http://www.baermann.biz/pauke/index.php?catid=9&blogid=1>
- Movie Clips
 - 12 O' Clock High
 - Memphis Belle
 - Dr. Strangelove

This Presentation is on YouTube

Watch This Talk Online

http://www.youtube.com/watch?v=ZTC_RxWN_xo